

ARISTA



Quick Start Guide **Edge Threat Management** **Appliance**

CCA-ETM-Q6EWL

Arista Networks

www.arista.com

DOC-06005-02

Headquarters 5453 Great America Parkway, Santa Clara, CA 95054 USA +1-408 547-5500	Support +1-408 547-5502 +1-866 476-0000	Sales +1-408 547-5501 +1-866 497-0000
https://www.arista.com/en/	mailto:support@arista.com	mailto:support@arista.com

© Copyright 2023 Arista Networks, Inc. All rights reserved. The information contained herein is subject to change without notice. The trademarks, logos and service marks ("Marks") displayed in this documentation are the property of Arista Networks in the United States and other countries. Use of the Marks are subject to Arista Network Term of Use Policy, available at <http://www.arista.com/en/terms-of-use>. Use of marks belonging to other parties is for informational purposes only.

Contents

Chapter 1: Overview	1
1.1 Scope.....	1
1.2 Receiving and Inspecting the Equipment.....	1
1.3 Installation Process.....	2
1.4 Safety Information.....	3
1.5 Obtaining Technical Assistance.....	3
1.6 Specifications.....	4
Chapter 2: Preparation	5
2.1 Site Selection.....	5
2.2 Tools and Parts Required for Installation.....	6
2.3 Electrostatic Discharge Precautions.....	6
Chapter 3: Mounting the Appliance	7
3.1 Desktop Installation.....	7
3.2 Rack Mounting the Appliance.....	8
3.2.1 Mounting the Power Supply.....	10
3.2.2 Attaching Mounting Brackets to the Chassis.....	11
3.2.3 Inserting the Appliance into the Rack.....	12
3.3 Mounting the Appliance on a Wall.....	13
Chapter 4: Cabling the Appliance	15
Chapter 5: Configuring the Appliance	17
Appendix A: Status Indicators	19
A.1 Front Indicators.....	19
Appendix B: Parts List	21
Appendix C: Front Panel	23
Appendix D: Rear Panel	25
Appendix E: Regulatory Model Numbers	27
Appendix F: Product Compliance	29

Appendix G: Taiwan RoHS Information..... 31

Overview

This guide is intended for properly trained service personnel and technicians who need to install selected Arista Appliances.

The following topics are covered in this section:

- [Scope](#)
- [Receiving and Inspecting the Equipment](#)
- [Installation Process](#)
- [Safety Information](#)
- [Obtaining Technical Assistance](#)
- [Specifications](#)

1.1 Scope

This guide is intended for properly trained service personnel and technicians who need to install the following Arista Appliance:

CCA-ETM-Q6EWL



Important:

Only qualified personnel should install, service, or replace this equipment.

Seul le personnel qualifié doit installer, service, ou remplacer cet équipement.

1.2 Receiving and Inspecting the Equipment

Upon receiving the appliance, inspect the shipping boxes and record any external damage. Retain packing materials if you suspect that part of the shipment is damaged; the carrier may need to inspect them.

If the boxes were not damaged in transit, unpack them carefully. Ensure that you do not discard any accessories that may be packaged in the same box as the main unit.

Inspect the packing list and confirm that you received all listed items. Compare the packing list with your purchase order. Parts List provides a list of components included with the appliance.

1.3 Installation Process

The following tasks are required to install and use the appliance:

1. Select and prepare the installation site ([Site Selection](#)).
2. Assemble the installation tools listed ([Tools and Parts Required for Installation](#)).
3. Install the appliance ([Mounting the Appliance](#)).
4. Connect the appliance to the power source and network appliances ([Cabling the Appliance](#)).
5. Configure the appliance ([Configuring the Appliance](#)).



Important:

Class 1 Laser Product: This product has provisions to install Class 1 laser transceivers which provide optical coupling to the communication network. Once a Class 1 laser product is installed, the equipment is a Class 1 Laser Product. The customer is responsible for selecting and installing the Class 1 laser transceiver and for insuring that the Class 1 AEL (Allowable Emission Limit) per EN/IEC 60825, CSA E60825-1, and Code of Federal Regulations 21 CFR 1040 is not exceeded after the laser transceiver have been installed. Do not install laser products whose class rating is greater than 1. Refer to all safety instructions that accompanied the transceiver prior to installation. Only Class 1 laser Appliances, certified for use in the country of installation by the cognizant agency are to be utilized in this product.

Produit Laser de classe 1: Ce produit a des dispositions pour installer des émetteurs-récepteurs de laser de classe 1 qui offre de couplage au réseau de communication optique. Une fois un produit laser de classe 1 est installé, l'équipement est un produit Laser de classe 1 (Appareil à Laser de Classe 1). Le client est responsable pour sélectionner et installer l'émetteur/récepteur de laser de classe 1 et pour assurer que la classe 1 AEL (limite d'émission admissible) par EN/IEC 6-825, CSA E60825-1, et Code des règlements fédéraux 21 CFR 1040 ne soit pas dépassée après avoir installé l'émetteur/récepteur de laser. Ne pas installer des appareils à laser dont la cote de classe est supérieure à 1. Voir toutes les consignes de sécurité qui ont accompagné l'émetteur-récepteur avant l'installation. Seuls appareils laser de classe 1 certifiés pour une utilisation dans le pays d'installation par l'organisme compétent doivent être utilisées dans ce produit.



Important:

Ultimate disposal of this product should be handled in accordance with all national laws and regulations.

Aucune pièce réparable par l'utilisateur à l'intérieur. Confiez toute réparation à un technicien qualifié.

1.4 Safety Information

Refer to the Arista Networks document *Safety Information and Translated Safety Warnings* available at: <https://www.arista.com/en/support/product-documentation>.

1.5 Obtaining Technical Assistance

Any customer, partner, reseller, or distributor holding a valid Arista Service Contract can obtain technical support in any of the following ways:

- **Email:** <http://support@arista.com>. This is the easiest way to create a new service request.
- **Web:** <https://www.arista.com/en/support>.

A support case may be created through the support portal on our website. You may also download the most current software and documentation, as well as view FAQs, Knowledge Base articles, Security Advisories, and Field Notices.

- **Phone:** +1 866-476-0000 or +1 408-547-5502.



Important:

No user serviceable parts inside. Refer all servicing to qualified service personnel.

Aucune pièce réparable par l'utilisateur à l'intérieur. Confiez toute réparation à un technicien qualifié.

1.6 Specifications

Table 1: Appliance Specifications (Dimensions and Weights)

Appliance	Size (W x D x H)	Weight
CCA-ETM-Q6EWL	232mm x 174mm x 42mm	1.4 kg

Table 2: Appliance Specifications (Operational and Storage)

Appliance	Operating Temperature and Relative Humidity	Storage Temperature and Relative Humidity	Operating Altitude
CCA-ETM-Q6EWL	0°C to 40°C 10 to 90% RH	-20°C to 70°C 5 to 95% RH	Sea level to 5000 meters.

Table 3: Appliance Specifications (Power Input)

Power Source	Ratings
AC INPUT - 40W Power Adapter	100~240V, 1.2A, 50-60Hz

Preparation

The following topics are covered in this section:

- [Site Selection](#)
- [Tools and Parts Required for Installation](#)
- [Electrostatic Discharge Precautions](#)

2.1 Site Selection

The following criteria should be considered when selecting a site to install the appliance.

- **Temperature and Ventilation:** For proper ventilation, install the appliance where there is ample airflow to the front and back of the appliance. The ambient temperature should not go below 0° or exceed 40°C.



Important: To prevent the appliance from overheating, do not operate it in an area where the ambient temperature exceeds 40°C (104°F).

Pour empêcher l'interrupteur de surchauffe, ne pas utiliser il dans une zone où la température ambiante est supérieure à 40°C (104°F).

- **Rack Space:** Install the appliance in a 19" rack or cabinet. The appliance height is 1 RU. The rack mounting kit provides mounting brackets for two-post racks.

When mounting the appliance in a partially filled rack, load the rack from bottom to top, with the heaviest equipment at the bottom. Load the appliance at the bottom if it is the only item in the rack.

- **Other Requirements:** Select a site where liquids or objects cannot fall onto the equipment and foreign objects are not drawn into the ventilation holes. Verify these guidelines are met:
 - Clearance areas to the front and rear panels allow for unrestricted cabling.
 - All front and rear panel indicators can be easily read.
 - Power cords can reach from the power outlet to the connector on the rear panel.



Important: All power connections must be removed to de-energize the unit.

Toutes les connexions d'alimentation doivent être enlevées pour hors tension l'appareil.

2.2 Tools and Parts Required for Installation

The following tool(s) are required for installation:

- Philips #2 screwdriver

2.3 Electrostatic Discharge Precautions

Observe these guidelines to avoid ESD damage when installing or servicing the appliance

- Assemble or disassemble equipment only in a static-free work area.
- Use a conductive work surface (such as an anti-static mat) to dissipate static charge.
- Wear a conductive wrist strap to dissipate static charge accumulation.
- Minimize handling of assemblies and components.
- Keep replacement parts in their original static-free packaging.
- Remove all plastic, foam, vinyl, paper, and other static-generating materials from the work area.
- Use tools that do not create ESD.

Mounting the Appliance

The following topics are covered in this chapter:

- [Desktop Installation](#)
- [Rack Mounting the Appliance](#)
- [Mounting the Appliance on a Wall](#)

3.1 Desktop Installation

To install the CCA-EMT-Q6EWL on a desktop, complete the following steps.

1. Remove the four screws on the wall mount bracket on the bottom of the appliance.
2. Remove the wall mount bracket from the bottom of the appliance.
3. Attach the rubber feet to the bottom corners of the appliance.
4. Attach the cables according to [Cabling the Appliance](#).

3.2 Rack Mounting the Appliance

To mount the appliance onto a two-post rack, mount the power supply unit, assemble the mounting brackets to the chassis, and then attach the brackets to the rack posts.

The following topics are covered in this section:

- [Mounting the Power Supply](#)
- [Attaching Mounting Brackets to the Chassis](#)
- [Inserting the Appliance into the Rack](#)

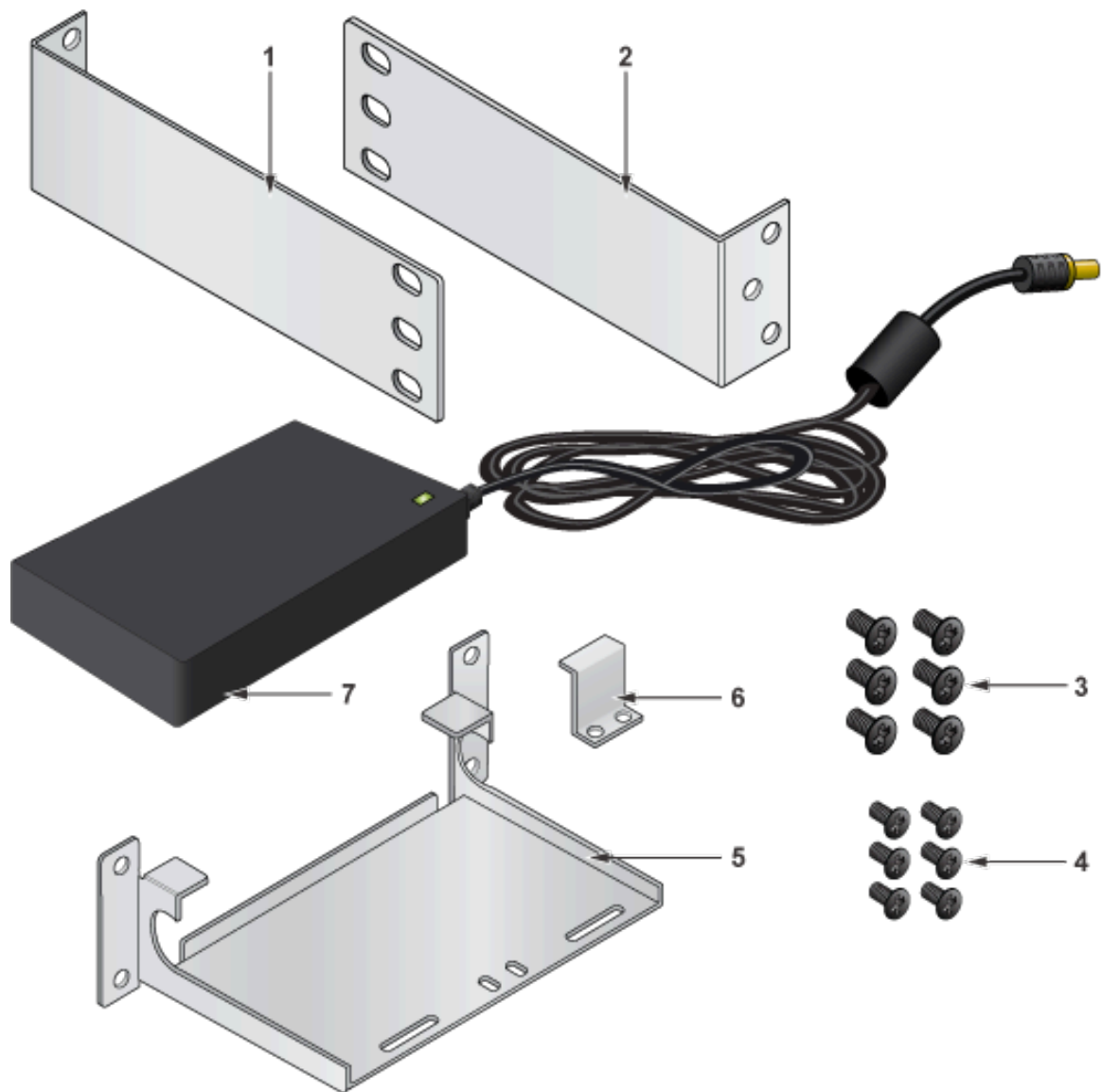

- | | | | |
|---|-----------------------|---|----------------------|
| 1 | Rack mounting bracket | 5 | Power supply bracket |
| 2 | Rack mounting bracket | 6 | Fastening plate |
| 3 | Mounting screws | 7 | Power supply |
| 4 | Mounting screws | | |

Figure 1: CCA-ETM-Q6EWL Mounting Parts Kit

3.2.1 Mounting the Power Supply

The following describes the process for mounting the power supply unit.

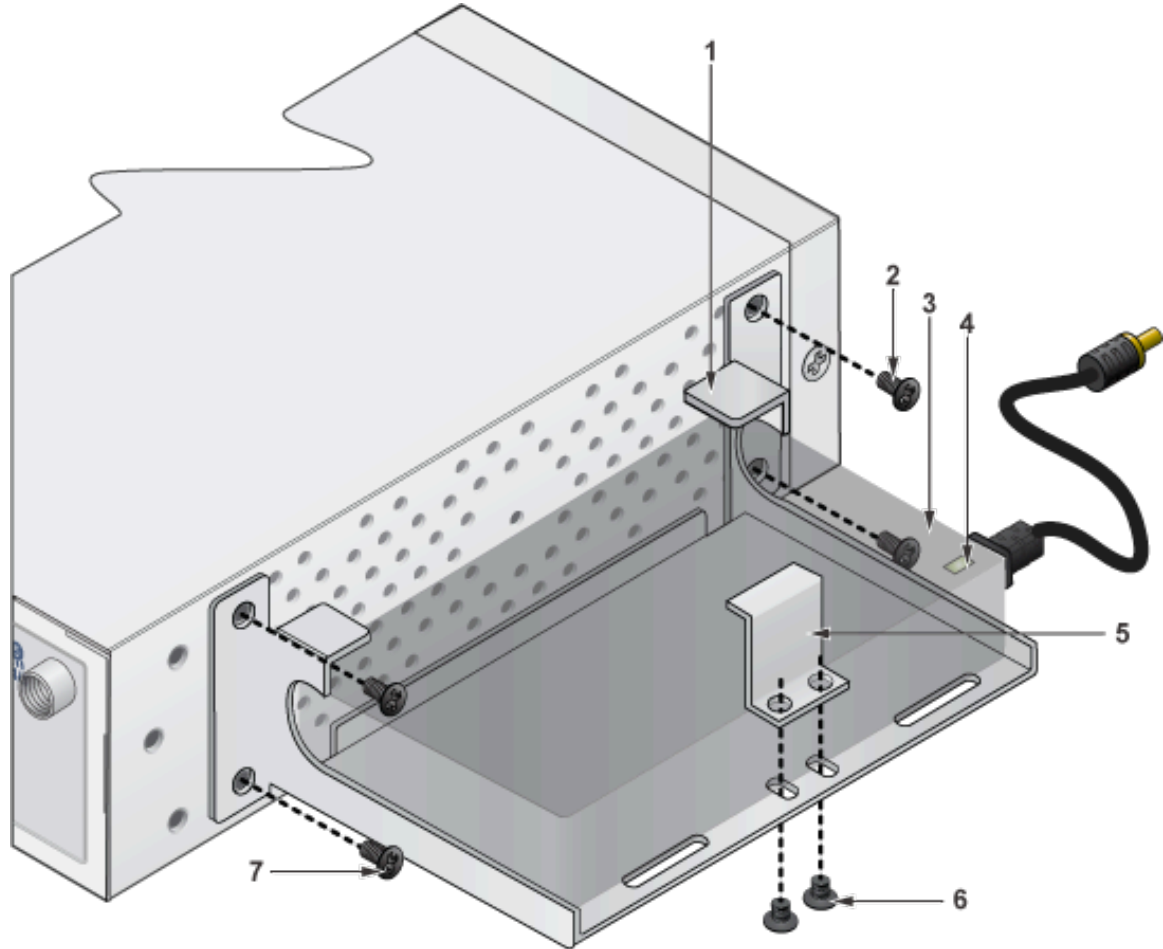

1. Line up the power supply bracket (1) with the holes on the side of the appliance.
2. Insert screws (2, 7) through the power supply bracket into the appliance.
3. Place 40W PSU (3) inside the bracket.
4. Secure PSU with fastening plate (5) and screws (6).

3.2.2 Attaching Mounting Brackets to the Chassis

This procedure attaches mounting brackets to the appliance chassis.

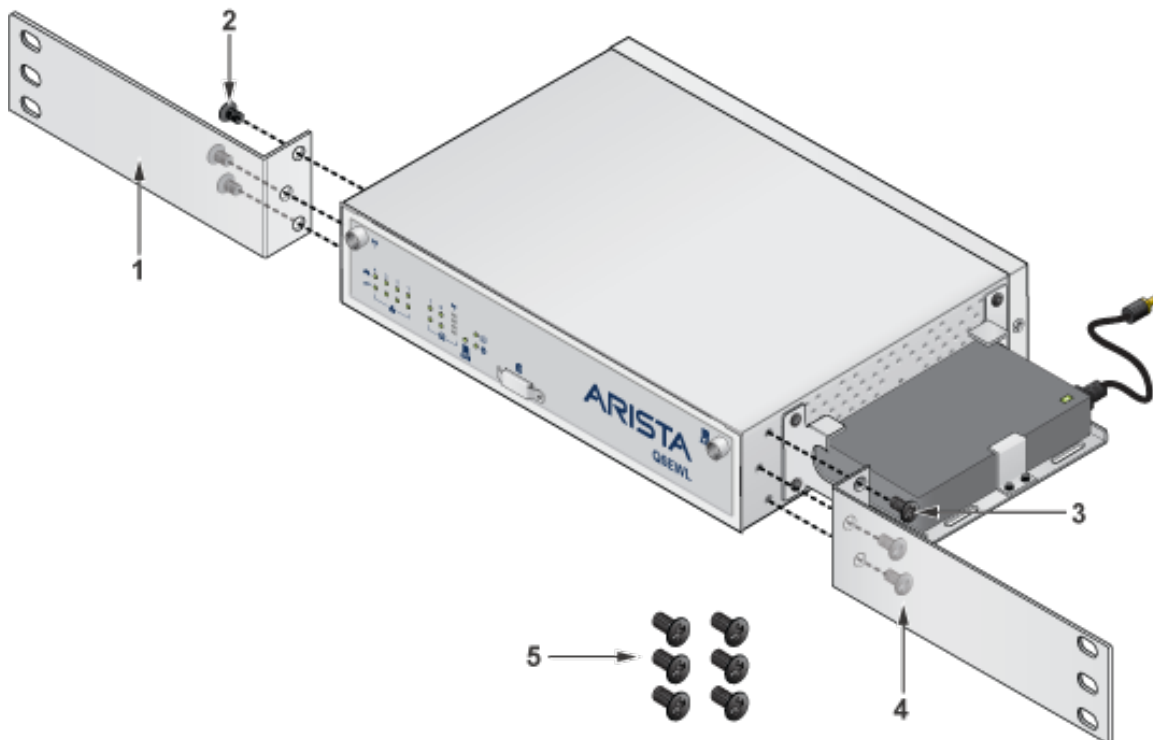

1. Remove the four screws on the wall mount bracket on the bottom of the appliance.
2. Remove the wall mount bracket from the bottom of the appliance.
3. Place the mounting bracket (1) flush against one side and to the front of the chassis so that the holes in the bracket and the chassis are in line for the attachment screws.
4. Use three screws (2) to attach the bracket to the chassis.
5. Attach the second bracket (4) to the other side of the chassis with three screws (3).



Note: The bracket will extend away from the chassis and provide three larger holes to attach to the rack as shown above.

3.2.3 Inserting the Appliance into the Rack

This procedure attaches the appliance to the rack.

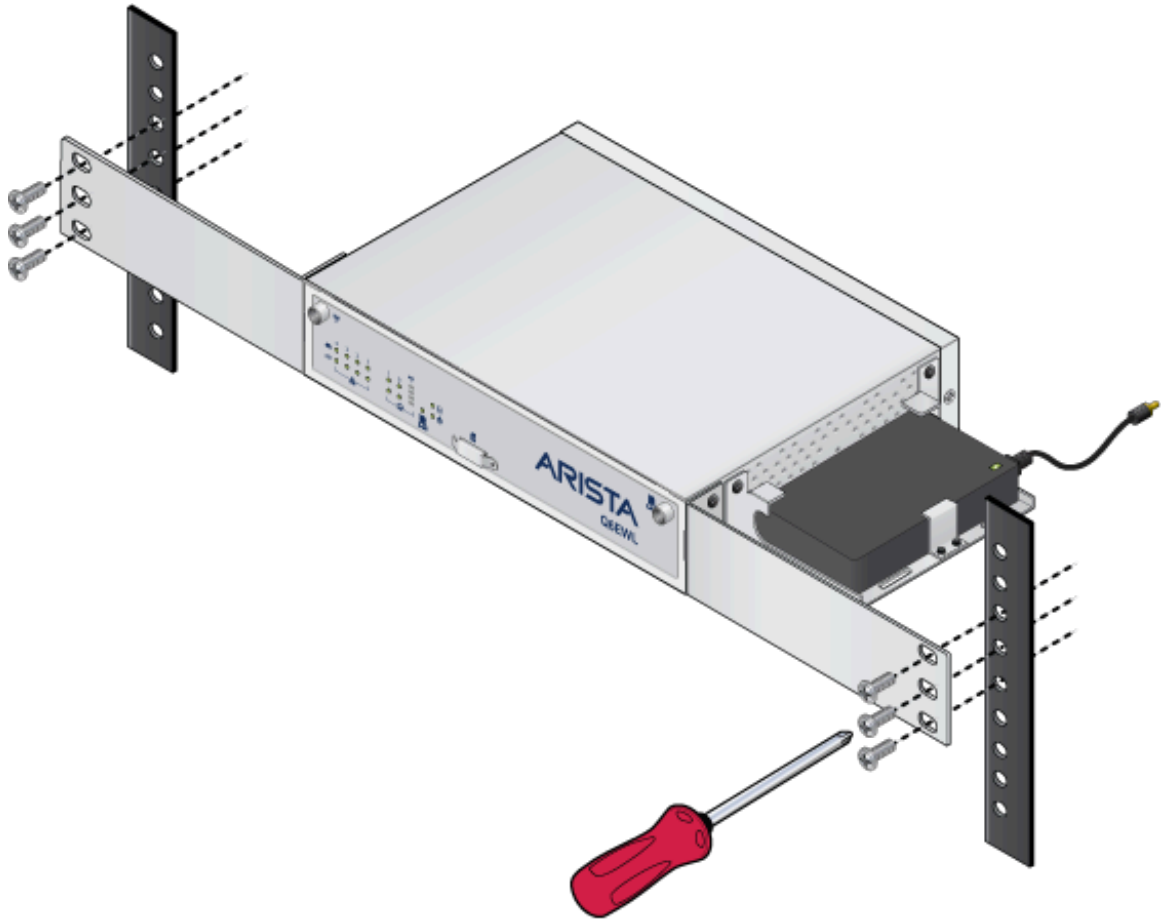

1. Lift the chassis into the rack. Position the brackets against the rack posts at the same level.
2. Select mounting screws that fit your equipment rack.
 -  **Note:** Screws required to attach the chassis to the posts are not included. Use the appropriate screws for the rack posts being used.
3. Attach the brackets to the rack posts.

3.3 Mounting the Appliance on a Wall

You can mount the appliance on a wall or place the appliance on a flat surface, such as a desk or a shelf.

Figure 2: Steps 1 and 2

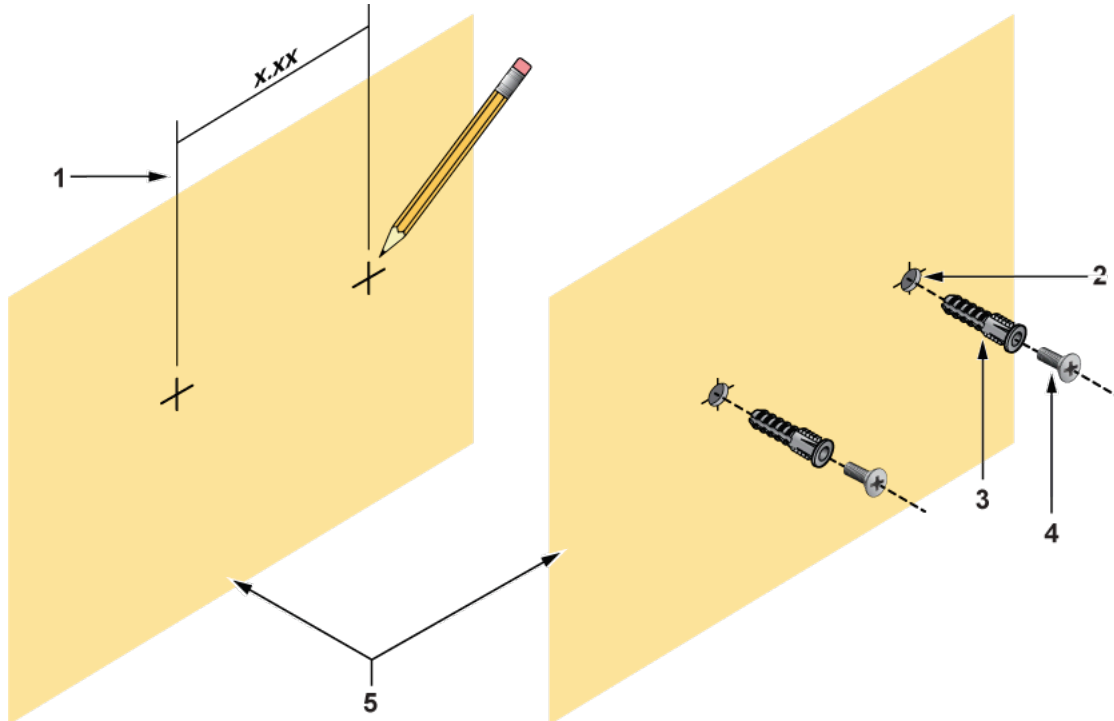

1. Drill two holes apart in the wall in a vertical or horizontal orientation(2), you can remove the VESA mounting bracket and use the holes as guides to mark the wall for drilling(1).



Note: Make sure you leave enough clearance around the appliance.

2. Insert nylon plugs into the holes(3), then insert two 32mm x 6.35mm flat undercut screws into the plugs(4).



Note: Nylon plugs are only necessary when mounting the appliance to drywall.

Figure 3: Steps 3 and 4

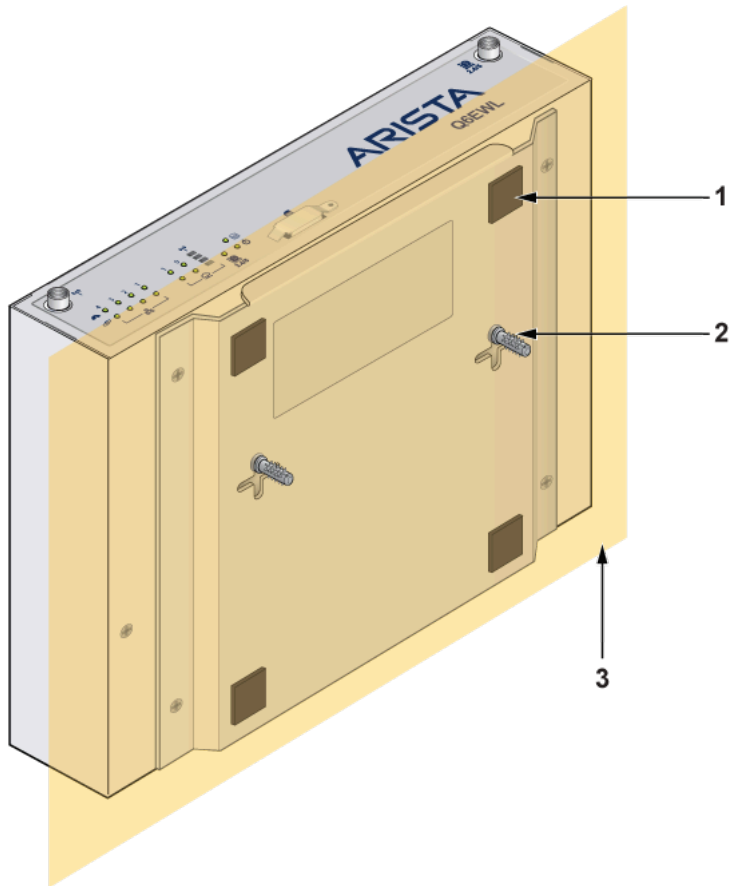

3. Attach the four provided rubber feet to aid ventilation(1).
4. Align the mounting holes on the appliance with the screws, then place the appliance on the screws(2).

Cabling the Appliance

For all installations:

1. Plug in the power adapter to a power source and connect it to the DC 12V power input on the rear panel.
2. Connect an Ethernet cable from your Internet modem or router to WAN Port 1.
3. Connect an Ethernet cable from your local network to LAN Port 1.
4. Connect a WiFi antenna to the WiFi antenna port on the rear panel.
5. Connect an LTE antenna to the LTE antenna port on the rear panel.
6. Connect a WiFi antenna to the WiFi antenna port on the front panel.
7. Connect an LTE antenna to the LTE antenna port on the front panel.
8. Power on the system by pressing the power button located on the rear panel next to the power input.
9. Allow approximately two minutes for the system to initialize before continuing with the next steps

Configuring the Appliance

You can manage your appliance using the **Edge Threat Management Dashboard** or from the local network.

From Edge Threat Management Dashboard

1. Navigate your web browser to <https://edge.arista.com/cmd>.
2. Log in with your Edge Threat Management Dashboard account, or click **Create Account** to set up an account.
3. Navigate to the Appliances screen and click **Add**.
4. Enter the serial number located on the bottom of your appliance.
5. Click **Add** to confirm the new appliance.
6. Complete the initial setup to begin managing your appliance.

From the local network

1. Connect an Ethernet cable from your management computer or LAN appliance to the LAN port.
2. From your management computer, check the network status of your system and confirm that you receive an IPv4 address in the subnet of **192.168.1.0/24** (e.g. **192.168.1.100**).
3. In a browser, navigate to <http://192.168.1.1>.
4. Follow the steps in your browser to complete the setup.

Status Indicators

The following topics are covered in this section:

- [Front Indicators](#)

A.1 Front Indicators

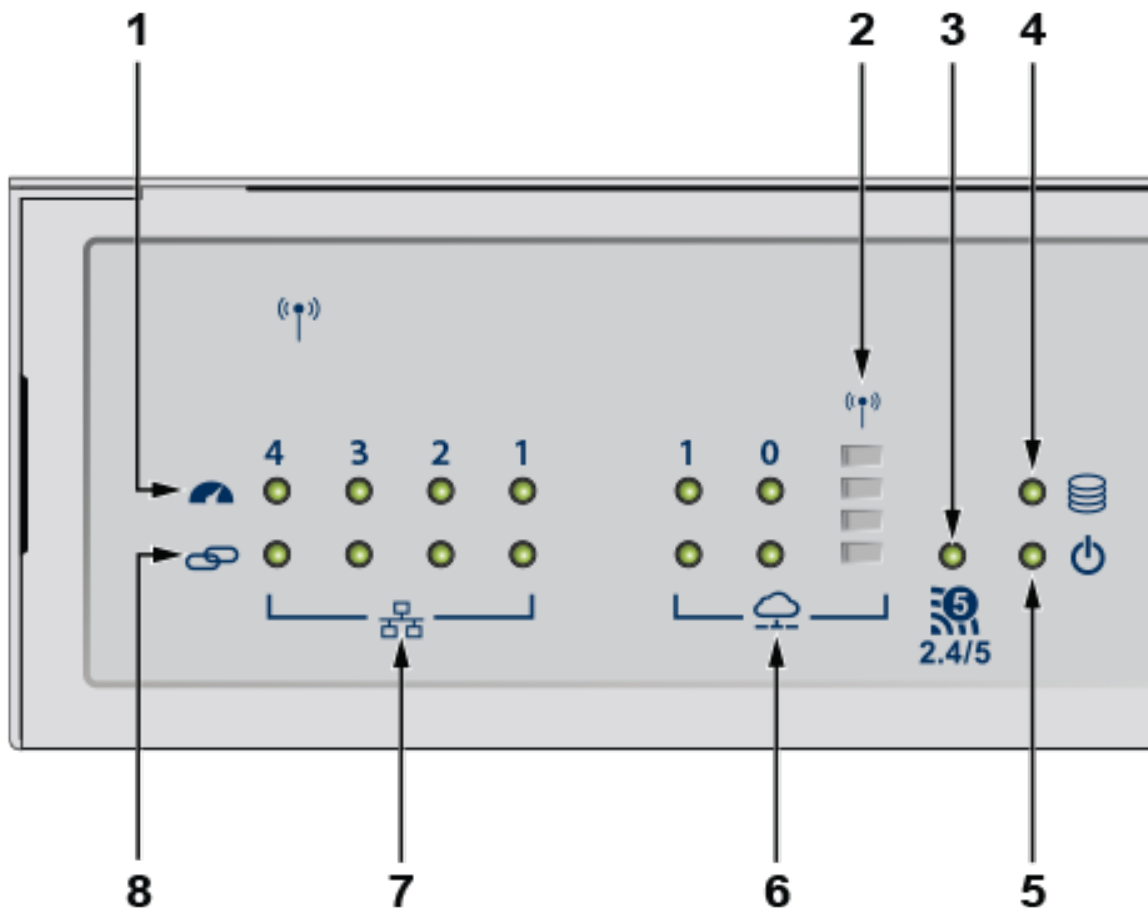

- | | |
|----------------|-------------------------------|
| 1 Speed status | 5 Power |
| 2 LTE | 6 WAN/SFP connections |
| 3 WiFi | 7 LAN Gb Ethernet connections |
| 4 Data | 8 Connection status |

Parts List

Package Contents

The CCA-ETM-Q6EWL package includes:

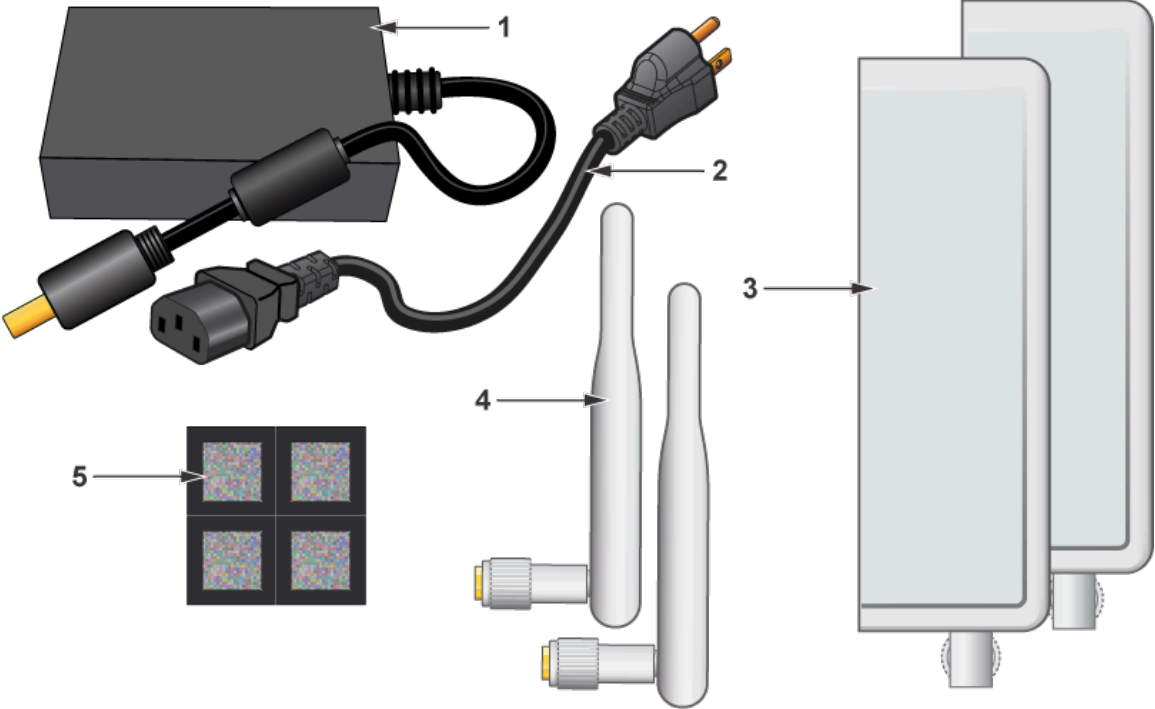

1 Power adapter

2 Power cable

3 LTE antennas (2)

4 WiFi antennas (2)

5 Rubber feet (4)

Front Panel

This appendix displays the front panel of all appliances covered by this guide.

Figure 4: Q6EWL Front Panel

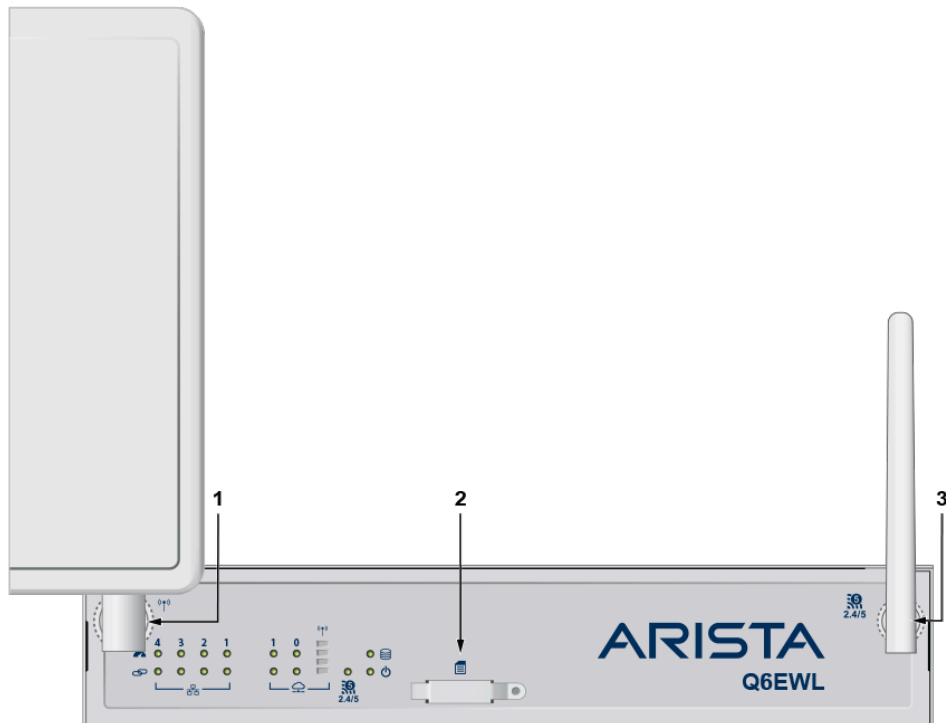

- 1 LTE antenna
- 2 SIM card slot
- 3 WiFi antenna

Rear Panel

This appendix displays the rear panel of all appliances covered by this guide.

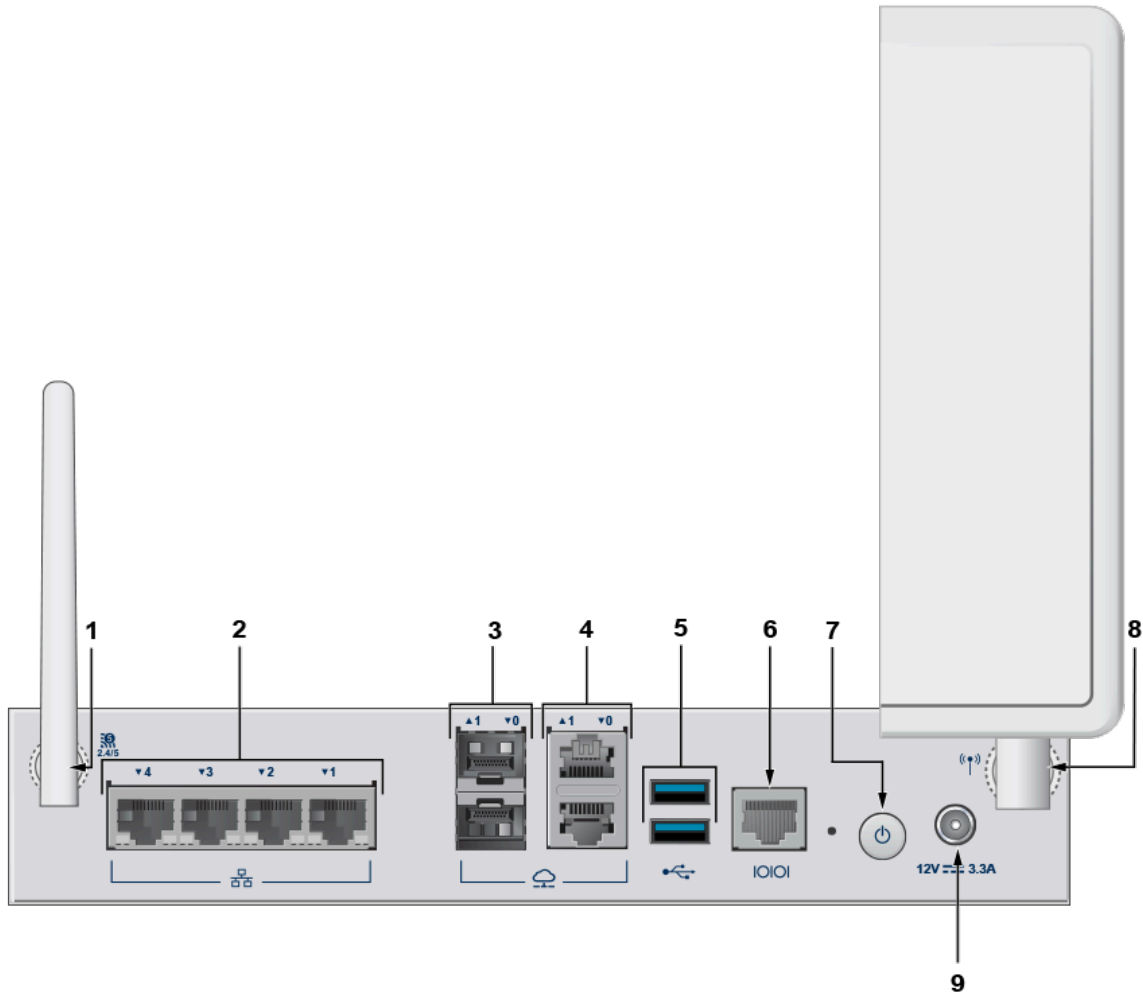

- | | |
|----------------------|----------------------|
| 1 WiFi antenna | 6 Console port |
| 2 LAN Ethernet port | 7 Power button |
| 3 SFP WAN ports | 8 LTE antenna |
| 4 Ethernet WAN ports | 9 Power adapter port |
| 5 3.0 USB ports | |

Regulatory Model Numbers

This appendix covers the Regulatory Model Number for the appliance in this guide.

Table 4: Regulatory Model Numbers and Product Numbers

Regulatory Model Numbers (RMN)	Product Numbers
AN2208, CAF-0262-5621-E92	CCA-ETM-Q6EWL

Product Compliance

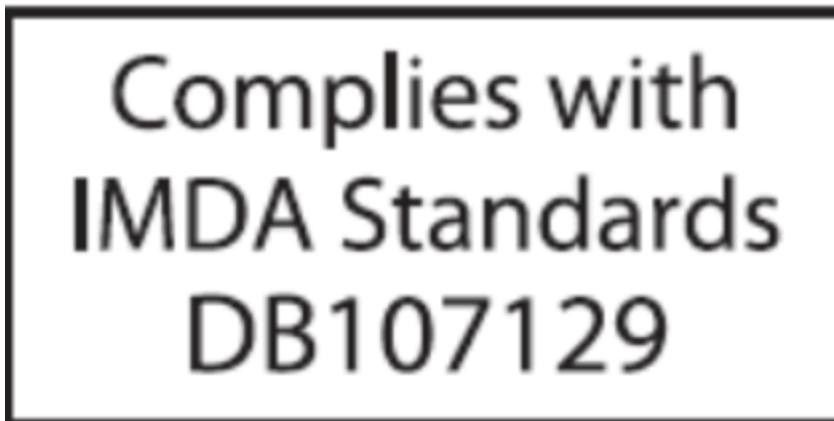

Figure 5: Singapore IMDA Registration Mark

Taiwan RoHS Information

This appendix provides Taiwan RoHS information for appliances covered by this guide.

For Taiwan BSMI RoHS Table, go to <https://www.arista.com/assets/data/pdf/AristaBSMIroHS.pdf>.

