

ARISTA

Quick Start Guide

DANZ Monitoring Fabric Service Node

DCA-DM-SNR660



[Arista.com](https://www.arista.com)

Arista Networks

DOC-08677-01

| Headquarters | Support | Sales |
|---|--|--|
| 5453 Great America Parkway Santa Clara, CA 95054 USA +1-408-547-5500 | +1-408-547-5502 +1-866-476-0000 | +1-408-547-5501 +1-866-497-0000 |
| www.arista.com/en/ | support@arista.com | sales@arista.com |

© Copyright 2026 Arista Networks, Inc. All rights reserved. The information contained herein is subject to change without notice. The trademarks, logos, and service marks ("Marks") displayed in this documentation are the property of Arista Networks in the United States and other countries. Use of the Marks is subject to the Arista Networks Terms of Use Policy, available at www.arista.com/en/terms-of-use. Use of marks belonging to other parties is for informational purposes only.

Contents

- Chapter 1: Overview..... 1**
 - 1.1 Scope..... 1
 - 1.2 Supplemental Documentation..... 1
 - 1.3 Obtaining Technical Assistance..... 1
 - 1.4 Safety Information..... 2
 - 1.5 Specifications..... 2

- Chapter 2: Set up Preparation..... 5**
 - 2.1 Site Selection..... 5
 - 2.2 Receiving and Inspecting the Equipment..... 5
 - 2.3 Electrostatic Discharge (ESD) Precautions..... 6
 - 2.4 Setting up Your System..... 6
 - 2.5 DMF Service Node Physical Appliance Setup..... 6
 - 2.5.1 Front Bezel..... 7
 - 2.5.2 Locate the MAC Addresses for the DMF Service Node Appliance..... 7
 - 2.5.3 Rear Panel Ethernet Connections..... 8
 - 2.5.4 DNS Entries..... 8
 - 2.6 DMF Service Node Appliance IP Configuration..... 8
 - 2.6.1 DHCP-Based IP Address Setup..... 9
 - 2.6.2 Manual IP Address Setup..... 9

- Chapter 3: DMF Service Node Appliance Access..... 10**
 - 3.1 iDRAC..... 10
 - 3.1.1 Web Access into iDRAC (System IPMI)..... 10
 - 3.1.2 Changing the iDRAC Password..... 11

- Chapter 4: Application Setup..... 14**
 - 4.1 Setting Up DMF Service Node..... 14
 - 4.1.1 Log into the DMF Service Node Web Interface..... 14

- Appendix A: Series Status Indicators..... 15**
 - A.1 LCD Panel Features..... 15
 - A.2 Status LED Indicators..... 16
 - A.2.1 iDRAC Direct LED Indicator Codes..... 17
 - A.3 NIC Indicator Codes..... 19
 - A.4 Power Supply Unit Indicator Codes..... 20

- Appendix B: Rack Installation..... 22**
 - B.1 Rack Installation..... 22
 - B.2 Two-Post Rack Mount Parts..... 25

- Appendix C: Front and Rear View of the System..... 26**

Appendix D: RoHS Declaration Statements..... 27

Overview

This section contains the following topics:

- [Scope](#)
- [Supplemental Documentation](#)
- [Obtaining Technical Assistance](#)
- [Safety Information](#)
- [Specifications](#)

1.1 Scope

This guide intends for properly trained service personnel and technicians who need to install the DMF Service Node Appliance.



CAUTION: Only qualified or trained personnel should install, service, or replace this equipment.

1.2 Supplemental Documentation

Refer to the Arista EOS User manual or additional configuration requirements at <https://www.arista.com/en/support/product-documentation>.

1.3 Obtaining Technical Assistance

All customers, partners, resellers, or distributors holding a valid Arista Service Contract can obtain technical support in any of the following ways:

- **Email:** <mailto:support@arista.com>

Include a detailed problem description and the “show tech-support” output.

- **Web:** <https://www.arista.com/en/support>

Create a support case through the support portal on our website. You may also download the most current software and documentation and view FAQs, Knowledge Base articles, Security Advisories, and Field Notices.

- **Phone:** +1 866-476-0000 or +1 408-547-5502

1.4 Safety Information

Refer to the Arista Networks document Safety Information and Translated Safety Warnings at: <https://www.arista.com/en/support/product-documentation>.

1.5 Specifications

The following appliance specifications table lists the DMF DCA-DM-SNR660 Service Node Appliance information.

Figure 1-1: System Dimensions

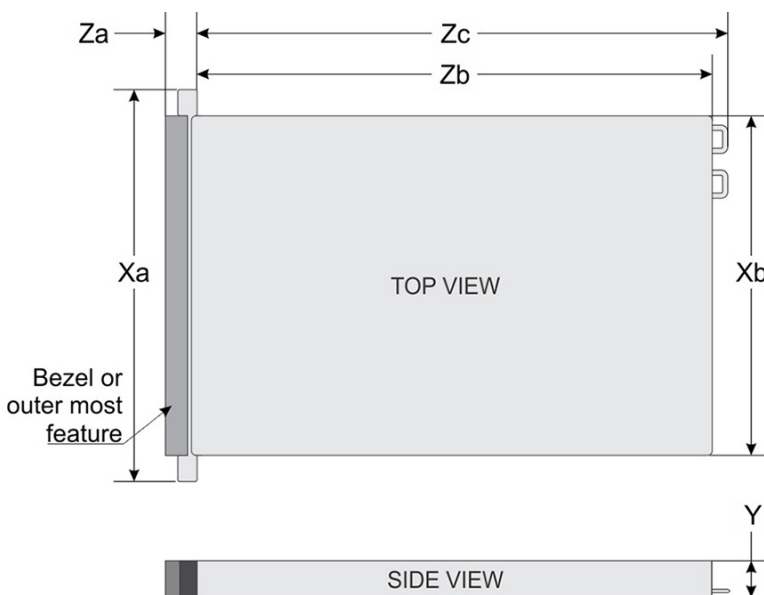

Table 1: System Specifications

| System | Dimensions |
|--------|--|
| Xa | 482.0 mm (18.97 inches) |
| Xb | 434.0 mm (17.08 inches) |
| Y | 42.8 mm (1.685 inches) |
| Za | 35.84 mm (1.41 inches) (with bezel) 22 mm (0.87 inches) (without bezel) |
| Zb | 677.1 mm (26.65 inches) (Ear to rear wall) |
| Zc | 712.95 mm (28.05 inches) (Ear to PSU handle without velcro strap) |

The following table shows the unit weight specifications with all drives/SSDs installed.

Table 2: Weight Specifications

| System Configuration | Maximum weight (with all drives/SSDs) |
|----------------------------|---------------------------------------|
| 4 x 3.5-inch | 19.45 kg |
| No backplane configuration | 15.38 kg |

The following table shows the power supply specifications.

Table 3: Power Specifications

| Power Draw | Specifications |
|-------------------------------|--|
| Power Draw (Typical) 550 W AC | Platinum 50/60 Hz 100 240 V AC, auto-arranging |
| Power Draw (Typical) 450 W AC | Bronze 50/60 Hz 100 240 V AC, auto-arranging |

The following table shows the optimal working temperature specifications.

Table 4: Temperature Specifications

| Temperature | Specifications |
|--|---|
| Non-operational | -40°C to 65°C (-40°F to 149°F) |
| Temperature ranges (For Altitude <900 meters or 2953 feet) | 5°C to 45°C (41°F to 113°F) with no direct sunlight on the equipment. |
| Maximum temperature gradient (operating and non-operational) | 20°C in an hour* (36°F in an hour) and 5°C in 15 minutes (9°F in 15 minutes), 5°C in an hour* (9°F in an hour) for tape hardware. |

The following table shows the relative humidity specification during operations and storage.

Table 5: Relative Humidity Specifications

| Relative Humidity | Specifications |
|-------------------|--|
| Non-operational | 5% to 95% RH with 27°C (80.6°F) maximum dew point. The atmosphere must be non-condensing at all times. |
| Operational | 8% RH with -12°C (10.4°F) minimum dew point to 90% RH with 24°C (75.2°F) maximum dew point. Non-condensing at all times. |

The following table shows the maximum vibration specifications during operations and storage.

Table 6: Maximum Vibration Specifications

| Maximum Vibration | Specifications |
|-------------------|--|
| Operating | 0.21 Grms at 5 Hz to 500 Hz for 10 minutes (all operational orientation) |
| Storage | 1.88 Grms at 10 Hz to 500 Hz for 15 min (all six sides tested) |

The following table shows the maximum shock specifications during operations and storage.

Table 7: Maximum Shock Specifications

| Maximum Shock | Specifications |
|---------------|--|
| Operating | 6 G six consecutively shock pulses in the positive and negative x, y, and z axes up to 11 ms. |
| Storage | 71 G six consecutively shock pulses in the positive and negative x, y, and z axes (one pulse on each side of the system) up to 2 ms. |

The following table shows the maximum altitude specifications during operations and storage.

Table 8: Maximum Altitude Specifications

| Maximum Altitude | Specifications |
|------------------|----------------------|
| Operational | 3050 m (10,006 ft) |
| Non-operational | 12,000 m (39,370 ft) |

The following table shows the standard operating temperature during operations and storage.

Table 9: Standard Operating Temperature

| Standard Operating Temperature | Specifications |
|---|---|
| Continuous operation (for altitude less than 950 m or 3117 ft). | 10°C to 35°C (50°F to 95°F) with no direct sunlight on the equipment. |

Set up Preparation

This chapter contains the following topics:

- [Site Selection](#)
- [Receiving and Inspecting the Equipment](#)
- [Electrostatic Discharge \(ESD\) Precautions](#)
- [Setting up Your System](#)
- [DMF Service Node Physical Appliance Setup](#)
- [DMF Service Node Appliance IP Configuration](#)

2.1 Site Selection

Before you begin, read the safety instructions in your Safety, Environmental, and Regulatory Information booklet.

Consider the following criteria when selecting a site to install the appliance:

- Before you begin, review the safety instructions located at <https://www.arista.com/en/support/product-documentation>.
- Begin installing the rails in the allotted space closest to the bottom of the rack enclosure.
- Other Requirements: Select a site where liquids or objects cannot fall onto the equipment and foreign objects are not drawn into the ventilation holes. Verify these guidelines are met:
 - Clearance areas to the front and rear panels allow for unrestricted cabling.
 - All front and rear panel indicators are visible.
 - Power cords can reach from the power outlet to the connector on the rear panel.



Note: Remove all power connections to de-energize the unit.



Note: You can install this unit in restricted access areas.

2.2 Receiving and Inspecting the Equipment

Upon receiving the appliance, inspect the shipping boxes and record any external damage. If you suspect that part of the shipment is damaged, retain packing materials; the carrier may need to inspect them

If the boxes are in pristine condition in transit, unpack them carefully. Do not discard accessories packaged in the same box as the main unit.

Inspect the packing list and confirm that you received all listed items. Compare the packing list with your purchase order. The Appendix provides a list of components included with the appliance.

2.3 Electrostatic Discharge (ESD) Precautions

Observe these guidelines to avoid ESD damage when installing or servicing the appliance.

- Assemble or disassemble equipment only in a static-free work area.
- Use a conductive work surface (such as an anti-static mat) to dissipate static charge.
- Wear a conductive wrist strap to dissipate static charge accumulation.
- Minimize handling of assemblies and components.
- Keep replacement parts in their original static-free packaging.
- Remove all plastic, foam, vinyl, paper, and other static-generating materials from the work area.
- Use tools that do not create ESD.

2.4 Setting up Your System

Complete the following steps to set up your system:

1. Unpack the system.
2. Remove the I/O connector cover from the system connectors.



Note: While installing the system, make sure, it is aligned properly with the slot on the enclosure

3. Install the system in the enclosure.
4. Turn on the enclosure.



Note: Wait for the chassis to initialize before you select the power button.

5. Press the power button on the system.

Alternatively, you can also turn on the system by using:

- The system iDRAC. For more information, see [Web Access into iDRAC \(System IPMI\)](#).
- The enclosure Chassis Management Controller (CMC), after the system iDRAC (IPMI) configures on the CMC.

2.5 DMF Service Node Physical Appliance Setup

You may need the following items to perform the procedures in this section:

- Key to the system keylock.
- #1 and #2 Phillips screwdriver.
- Wrist grounding strap connected to ground.
- Rack mount kit instructions are in the shipping box.

Before Working Inside your System

Follow these safety guidelines: [Safety Information](#).

1. Turn off the system, including all attached peripherals.
2. Disconnect the system from the electrical outlet and disconnect the peripherals.
3. Remove the system cover.

2.5.1 Front Bezel

Complete the following tasks to remove the front bezel.

Figure 2-1: Front Bezel

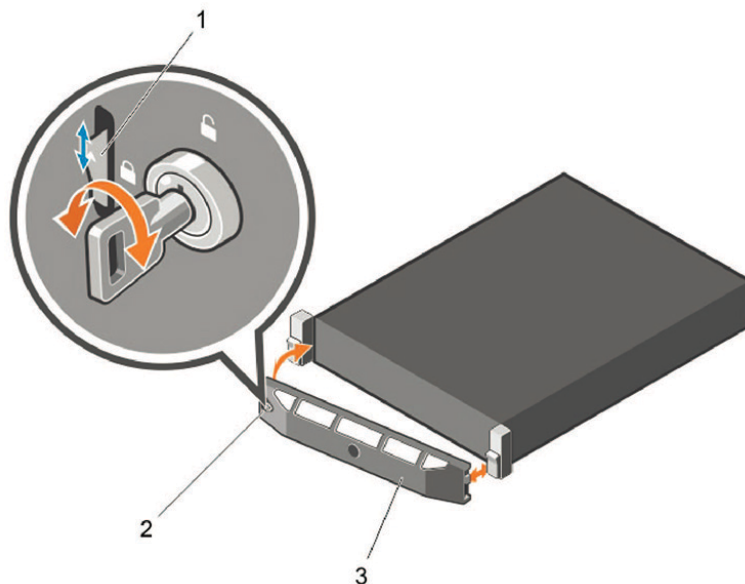

1. Unlock the keylock at the left end of the bezel.
2. Lift the release latch next to the keylock.
3. Rotate the left end of the bezel away from the front panel.
4. Unhook the right end of the bezel and pull the bezel away from the system.

2.5.2 Locate the MAC Addresses for the DMF Service Node Appliance

The information tag is a slide-out label that contains system information such as Service Tag, NIC, and MAC address for your reference. Record the MAC addresses in the DMF Service Node Appliance Worksheet.

Figure 2-2: Locating the MAC Address of your System

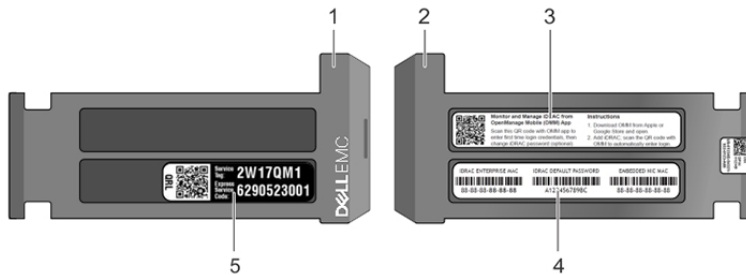

- | | | | |
|---|-------------------------------|---|--|
| 1 | Information tag (front view) | 4 | DRAC MAC address and iDRAC secure password label |
| 2 | Information tag (back view) | 5 | Service Tag |
| 3 | OpenManage Mobile (OMM) label | | |

2.5.3 Rear Panel Ethernet Connections

Locate the Ethernet Integrated 10/100/1000 Mbps NIC connectors on the back panel of the DMF Service Node appliance.

Figure 2-3: Rear Panel Ethernet Connections

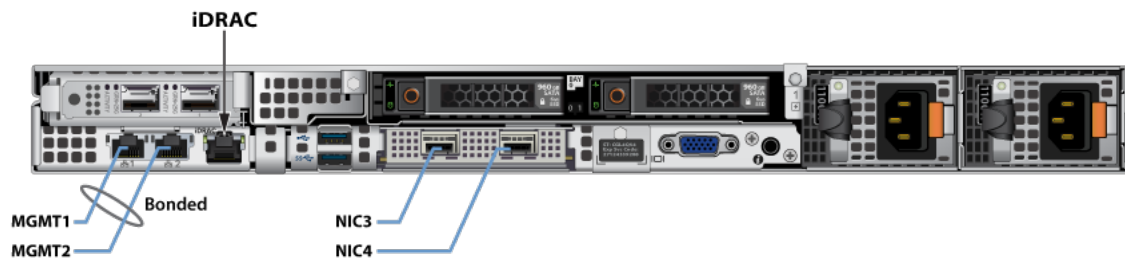

2.5.4 DNS Entries

To manage your DMF Service Node cluster, it is often easier to connect to them by hostname instead of IP address. Allocate Fully Qualified Domain Names (FQDNs) to:

- Each of the DMF Service Node Appliance host machines.
- Each of the DMF Service Node Appliance iDRAC interfaces.

Contact your DNS zone administrator for assistance.

2.6 DMF Service Node Appliance IP Configuration

You can allocate the DMF Service Node Appliance Host and iDRAC IP addresses in two ways:

Option 1: Using an available DHCP server

- DHCP-based IP address setup [DHCP-Based IP Address Setup](#).
- Web access into host via iDRAC [Web Access into iDRAC \(System IPMI\)](#).

Option 2: Manual configuration (Requires terminal connected to VGA port)

- Manual IP address setup [Manual IP Address Setup](#).
- Web access into host via iDRAC [Web Access into iDRAC \(System IPMI\)](#).

2.6.1 DHCP-Based IP Address Setup

Using the iDRAC MAC from [Locate the MAC Addresses for the DMF Service Node Appliance](#), input an entry into the DHCP Server for the corresponding iDRAC IP address mapping to that MAC.

2.6.2 Manual IP Address Setup

Direct IP Address Setup requires a terminal connected to the appliance's VGA port. Refer to Setting Up and Using iDRAC in the ***DMF Deployment Guide***.

DMF Service Node Appliance Access

This section contains the following topics:

- [iDRAC](#)

3.1 iDRAC

iDRAC is a GUI-based IPMI running on a separate out-of-band CPU to monitor the hardware appliance.

- [Web Access into iDRAC \(System IPMI\)](#)
- [Changing the iDRAC Password](#)

3.1.1 Web Access into iDRAC (System IPMI)

The following browsers support iDRAC:

- **Mozilla Firefox**
- **Google Chrome**

On the management station, open the Web browser and connect to the iDRAC7 using `https://<hostname or IP of iDRAC>`.

For example, `https://192.168.0.120`.

The Login page appears.

Figure 3-1: iDRAC Login Page

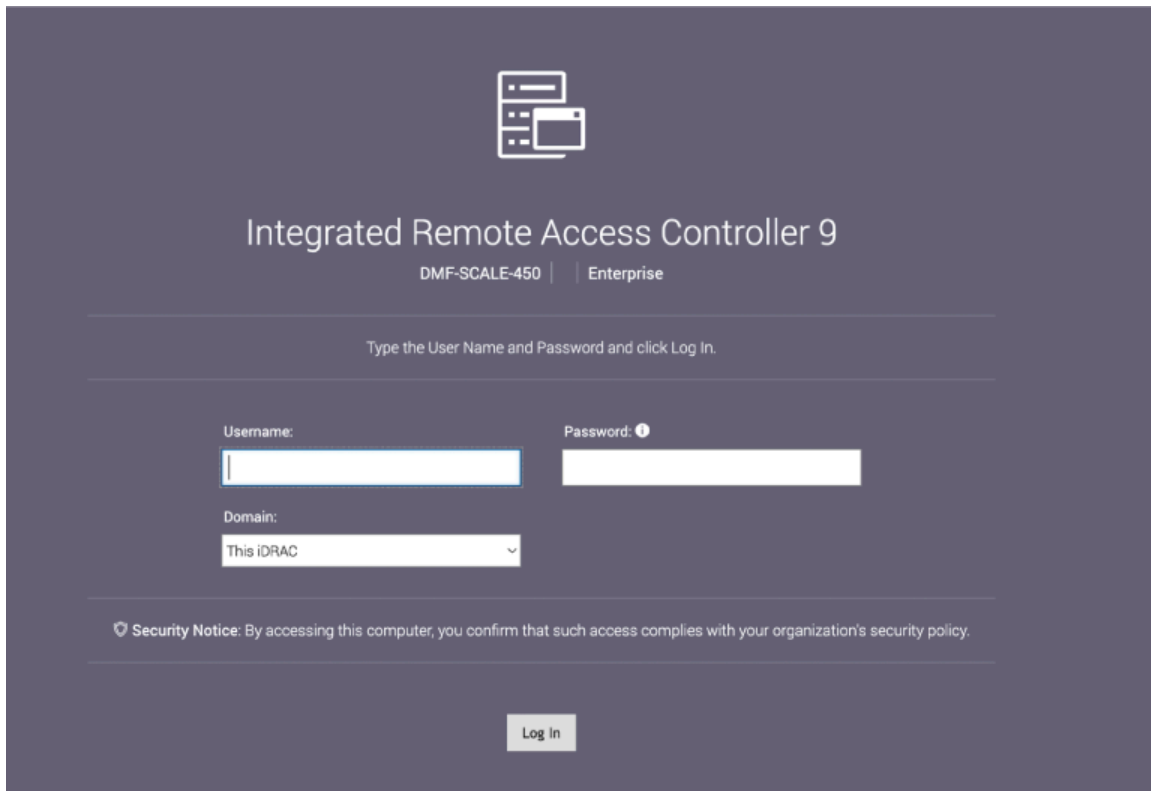

Login using the default username and password, which are:

- Username: **root**
- Password: **<password on the Service Tag>**



Note: Both the username and password are case-sensitive.

3.1.2 Changing the iDRAC Password

To change the iDRAC password, use the iDRAC Web Interface. Refer to [Changing the Password through the iDRAC Web Interface](#).

3.1.2.1 Changing the Password through the iDRAC Web Interface

Complete the following steps to change the password through the iDRAC web interface.

1. Log into iDRAC.

Figure 3-2: iDRAC Login Page

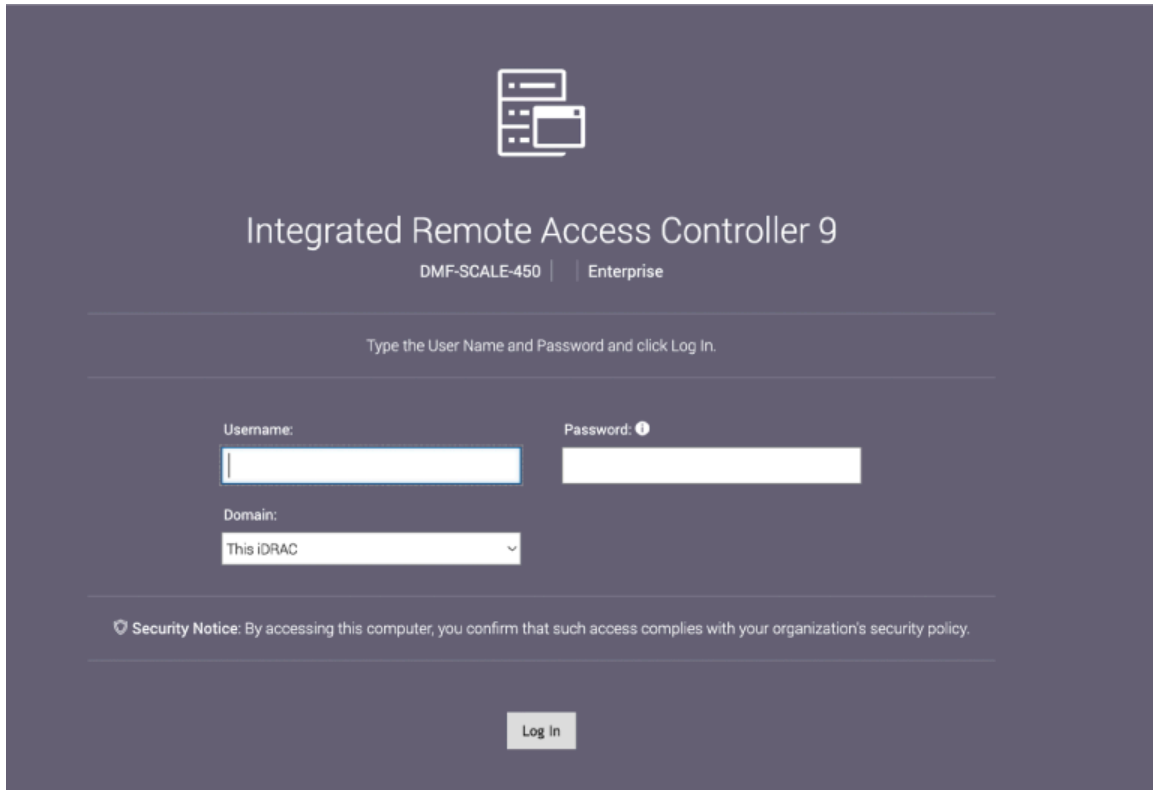

2. Under **iDRAC Settings**, go to **User**. Expand the Local Users and select the user whose password will be changed.

Figure 3-3: iDRAC Settings Page

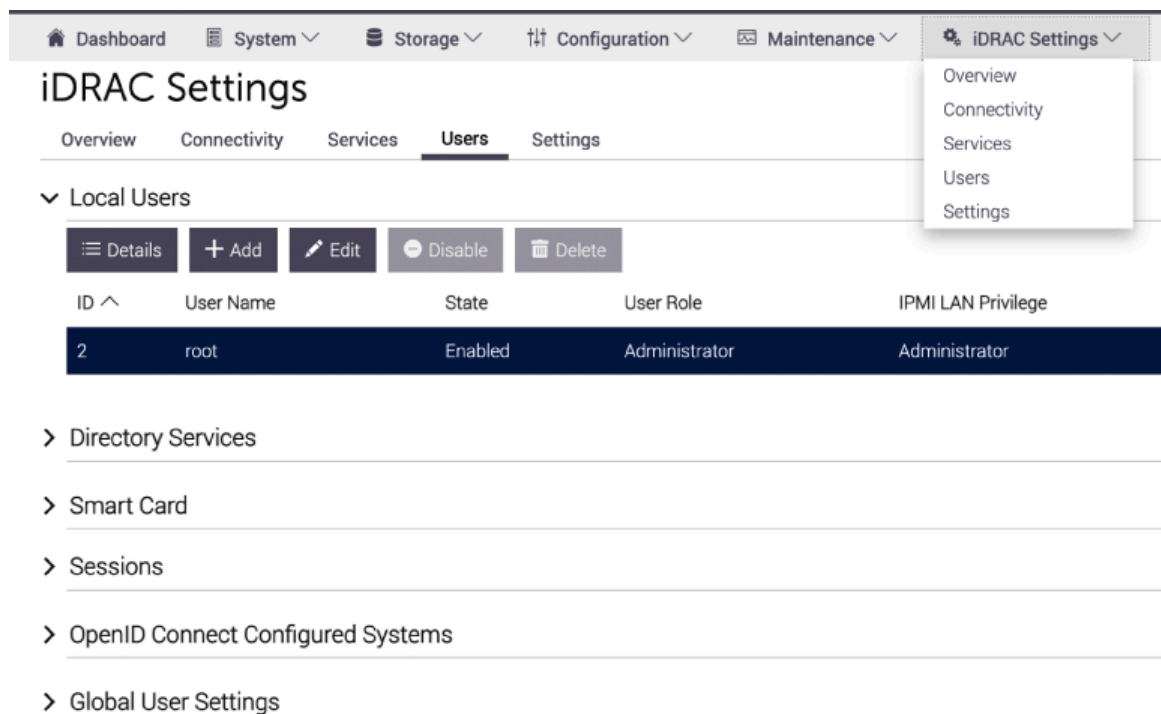

3. Click the **User ID** number of the root account.
4. Click **Edit**. The page will appear, showing options for changing the root user's Password.

Figure 3-4: Changing the Password

The screenshot shows the 'Edit User' page for user ID 2. The 'User Name' field contains 'root'. The 'Password' and 'Confirm Password' fields are masked with dots. The 'User Role' is set to 'Administrator'. Under 'User Privileges', all listed options are checked: Login to iDRAC, Clear Logs, Access Virtual Media, Configure iDRAC, Control and Configure System, Test Alerts, Configure Users, Access Virtual Console, and Execute Debug Commands. At the bottom right, there are 'Close' and 'Save' buttons.

| | | |
|--|--|--|
| ID | 2 | |
| User Name* | <input type="text" value="root"/> | |
| Password* | <input type="password" value="....."/> | |
| Confirm Password* | <input type="password" value="....."/> | |
| User Privileges | | |
| User Role | <input type="text" value="Administrator"/> | |
| <input checked="" type="checkbox"/> Login to iDRAC | <input checked="" type="checkbox"/> Configure iDRAC | <input checked="" type="checkbox"/> Configure Users |
| <input checked="" type="checkbox"/> Clear Logs | <input checked="" type="checkbox"/> Control and Configure System | <input checked="" type="checkbox"/> Access Virtual Console |
| <input checked="" type="checkbox"/> Access Virtual Media | <input checked="" type="checkbox"/> Test Alerts | <input checked="" type="checkbox"/> Execute Debug Commands |

5. Enter the new password in the **Password** and click **Confirm Password**.
6. Click **Save** to apply the password change.

Application Setup

This chapter contains the following topics:

- [Setting Up DMF Service Node](#)

4.1 Setting Up DMF Service Node

Pre-installation Checklist

- Ensure that the installation prerequisites are satisfied, as mentioned in the DMF Service Node Installation prerequisites section of the *DMF Deployment Guide*.
- To set up the Service Node appliance, please refer to *Installing and Upgrading the DMF Service Node* section of the *DMF Deployment Guide*.

4.1.1 Log into the DMF Service Node Web Interface

After the Service Node has been connected to the DMF switch fabric and configured (as per the steps outlined in the *DMF Deployment Guide*), enter the DMF Controller GUI via its IP/Hostname. The Service Node should be displayed as connected in the Managed Services page of the DMF GUI.

Refer to the *DMF User Guide* for instructions on using the DMF Service Node appliance.

Series Status Indicators

This section contains the following topics:

- [LCD Panel Features](#)
- [Status LED Indicators](#)
- [NIC Indicator Codes](#)
- [Power Supply Unit Indicator Codes](#)

A.1 LCD Panel Features

The system's LCD panel provides system information, status, and error messages to indicate if the system is operating correctly or needs attention.

The LCD backlight lights are blue during normal operating conditions. When the system needs attention, the LCD lights are amber and display an error code followed by descriptive text.



Note: When the system connects to a power source and if it detects an error, the LCD lights amber regardless of whether the system is on or off.

The LCD backlight turns **OFF** when the system is in standby mode. It can turn on by pressing the LCD panel's Select, Left, or Right buttons.

The LCD backlight remains **OFF** if LCD messaging is off through the iDRAC utility, the LCD panel, or other tools.

Figure A-1: LCD Panel Features



Table 10: LCD Panel Features Description

| Item | Button | Description |
|------|-------------|--|
| 1 | Left | Moves the cursor back in one-step increments. |
| 2 | Select | Selects the menu item highlighted by the cursor. |
| 3 | Right | Moves the cursor forward in one-step increments. During message scrolling: <ul style="list-style-type: none">• Press and hold the right button to increase the scrolling speed.• Release the button to stop. |
| 4 | LCD display | Displays system information, status, and error messages or iDRAC IP address. |

A.2 Status LED Indicators

 **Note:** The indicators display solid amber if any error occurs.

Figure A-2: LCD Panel Features

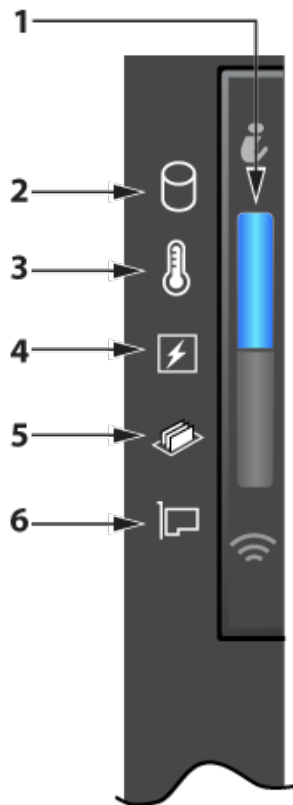







Table 11: Status LED Indicators and Descriptions

| Item | Description |
|------|---|
| 1 | The health indicator indicates the health status of the system. The indicator turns solid blue if the system is on and in good health. The indicator flashes amber if the system is on or on standby and any issue occurs (for example, a failed fan or drive). |
| 2 | The drive indicator flashes amber if an error related to the drive occurs. |
| 3 | The electrical indicator flashes amber if an electrical error occurs (for example, voltage out of range or a failed power supply unit or voltage regulator). |
| 4 | The temperature indicator flashes amber if a thermal error occurs (for example, temperature out of range or fan failure). |
| 5 | The memory indicator flashes amber if a memory error occurs. |
| 6 | The PCIe indicator flashes amber if an error related to the PCIe card occurs. |

Table 12: Icons Description

| Icon | Description | Condition | Corrective Action |
|---|-----------------------|---|---|
|  | Drive Indicator | The indicator turns solid amber if there is a drive error. | <ul style="list-style-type: none"> Check the System Event Log to determine if the drive has an error. Run the appropriate Online Diagnostics test. Restart the system and run embedded diagnostics (ePSA). Restart the system and enter the host adapter's configuration utility program when the drives are configured in a RAID array. |
|  | Temperature Indicator | The indicator turns solid amber if the system experiences a thermal error (for example, the ambient temperature is out of range or there is a fan failure). | <p>Ensure that none of the following conditions exist:</p> <ul style="list-style-type: none"> A cooling fan has been removed or has failed. The system cover, air shroud, memory module blank, or back filler bracket is not there. The ambient temperature is too high. The system obstructs the external airflow. |
|  | Electrical Indicator | The indicator turns solid amber if the system experiences an electrical error (for example, voltage out of range or a failed power supply unit (PSU) or voltage regulator). | Check the System Event Log or system messages for the specific issue. If it is due to a problem with the PSU, check the LED on the PSU. Reseat the PSU. |
|  | Memory Indicator | The indicator turns solid amber if a memory error occurs. | Check the System Event Log or system messages for the location of the failed memory. Reseat the memory module. |
|  | PCIe Indicator | The indicator turns solid amber if a PCIe card experiences an error. | Restart the system. Update any required drivers for the PCIe card. Reinstall the card. |

A.2.1 iDRAC Direct LED Indicator Codes

The iDRAC Direct LED indicator indicates that the port is connected and part of the iDRAC subsystem.

You can configure iDRAC Direct using a USB to micro USB (type AB) cable to connect to your laptop or tablet. The following table describes iDRAC Direct activity when the iDRAC Direct port is active.

The iDRAC Direct LED indicator codes table describes the iDRAC status when it is solid green, flashing green, and turned off.

Table 13: iDRAC Direct LED Indicator Codes

| iDRAC Direct LED Indicator Code | Condition |
|--|---|
| Solid green for two seconds. | Indicates that the laptop or tablet is connected. |
| Flashing green (on for two seconds and off for two seconds). | Indicates that the laptop or tablet connection is recognized. |
| LED indicator off | Indicates that the laptop or tablet is unplugged. |

A.2.1.1 iDRAC Quick Sync 2 Indicator Codes

The left control panel has the iDRAC Quick Sync 2 module (optional) on the system.

Figure A-3: iDRAC Quick Sync 2 Indicators



This table describes the Quick Sync status indicators. The indicator statuses are Off, which is the default state: Solid white, blinks white rapidly, blinks white slowly, blinks white five times rapidly and then turns off, solid amber, and blinking amber.

Table 14: iDRAC Quick Sync 2 Indicators and Descriptions

| iDRAC Quick Sync 2 indicator code | Condition | Corrective action |
|--|--|--|
| Off (default state) | Indicates that the iDRAC Quick Sync 2 feature is off. Press the iDRAC Quick Sync 2 button to turn on the iDRAC Quick Sync 2 feature. | Reseat the left control panel flex cable and check if the LED fails to turn on. |
| Solid white | Indicates that iDRAC Quick Sync 2 is ready to communicate. Press the iDRAC Quick Sync 2 button to turn it off. | If the LED fails to turn off, restart the system. |
| Blinks white rapidly | Indicates data transfer activity. | |
| Blinks white slowly | Indicates that a firmware update is in progress. | |
| Blinks white five times rapidly and then turns off | Indicates that the iDRAC Quick Sync 2 feature is disabled. | Check if iDRAC disables the iDRAC Quick Sync 2 feature configuration. |
| Solid amber | Indicates that the system is in fail-safe mode. | Restart the system. |
| Blinking amber | Indicates that the iDRAC Quick Sync 2 hardware is not responding properly. | Restart the system. |

A.3 NIC Indicator Codes

Each NIC on the back of the system has indicators that provide information about the activity and link status. The activity LED indicator indicates if data is flowing through the NIC, and the link LED indicator indicates the speed of the connected network.

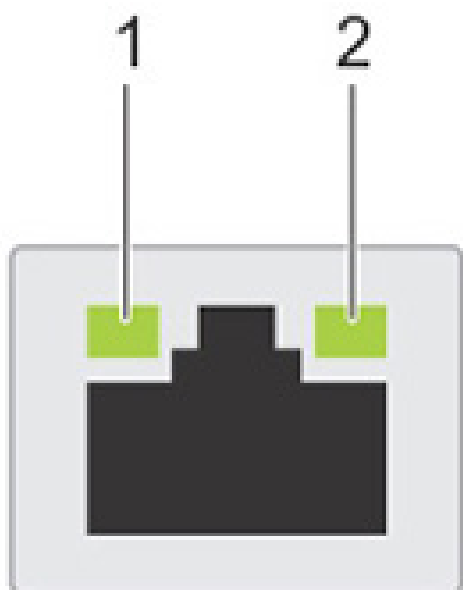
Figure A-4: NIC LED

1. Link LED indicator
2. Activity LED indicator

The NIC indicators table describes different NIC indicator codes and connectivity conditions.

Table 15: NIC Indicator Codes

| Status | Condition |
|--|--|
| Link and activity indicators are off. | The NIC is not on the network. |
| The link indicator is green, and the activity indicator is blinking green. | The NIC is on a valid network at maximum port speed, and data is being sent or received. |
| The link indicator is amber, and the activity indicator is blinking green. | The NIC is on a valid network at less than its maximum port speed, and data is being sent or received. |
| The link indicator is green, and the activity indicator is off. | The NIC is on a valid network at maximum port speed, and data is not being sent or received. |
| The link indicator is amber, and the activity indicator is off. | The NIC is on a valid network at less than its maximum port speed, and data is not being sent or received. |
| The link indicator is blinking green, and the activity is off. | NIC identity is enabled through the NIC configuration utility. |

A.4 Power Supply Unit Indicator Codes

AC power supply units (PSUs) have an illuminated translucent handle that is an indicator. The indicator shows whether power is present or if a power fault has occurred.



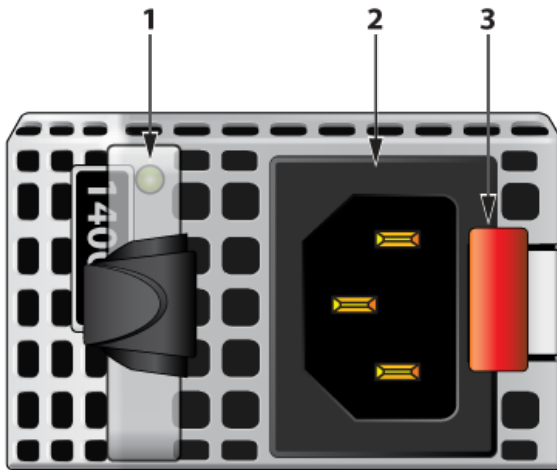

Figure A-5: Power Supply Unit Indicators



- 1 AC PSU status indicator/handle
- 2 Socket
- 3 Release latch

This table describes the AC PSU status indicators and their condition when the power indicator light is green, blinking green, blinking amber, and not illuminated.

Table 16: AC PSU Status Indicator Codes

| Power Indicator Codes | Condition |
|------------------------------|--|
| Green | The PSU connects to a valid power source, and the PSU is operational. |
| Blinking amber | Indicates a problem with the PSU. |
| Not illuminated | The PSU does not have power. |
| Blinking green | <p>The PSU handle blinks green through the firmware update.</p> <div style="border: 1px solid black; padding: 5px;">  CAUTION: Do not disconnect the power cord or unplug the PSU when updating the firmware. If the firmware update is interrupted, the PSUs do not function. </div> |
| Blinking green and turns off | <p>When hot-plugging a PSU, the PSU handle blinks green five times at a rate of 4 Hz and turns off. It indicates a PSU mismatch concerning efficiency, feature set, health status, or supported voltage.</p> <div style="border: 1px solid black; padding: 5px;">  CAUTION: If the system has two PSUs, both PSUs must have the same type of label; for example, an Extended Power Performance (EPP) label. Mixing PSUs from previous generations of PowerEdge servers is not supported, even if the PSUs have the same power rating. This results in a PSU mismatch or failure to turn the system on. </div> <div style="border: 1px solid black; padding: 5px;">  CAUTION: Replace only the PSU with the blinking indicator when correcting a PSU mismatch. Swapping the PSU to make a matched pair can result in an error condition and unexpected system shutdown. You must turn off the system to change from a high output configuration to a low output configuration or vice versa. </div> <div style="border: 1px solid black; padding: 5px;">  CAUTION: AC PSUs support 240 V and 120 V input voltages, except for Titanium PSUs, which support only 240 V. When two identical PSUs receive different input voltages, they can output different wattages and trigger a mismatch. </div> <div style="border: 1px solid black; padding: 5px;">  CAUTION: If the system has two PSUs, they must be the same type and have the same maximum output power. </div> |

Rack Installation

This section includes the following topics:

- [Rack Installation](#)
- [Two-Post Rack Mount Parts](#)

B.1 Rack Installation

Use the following steps to assemble the racking rails and attach the components to the system.

1. Identifying the Rail Kit Contents.

Locate the components for installing the rail kit assembly:

- Two sliding rail assemblies (1).
- Two hook and loop straps (2).

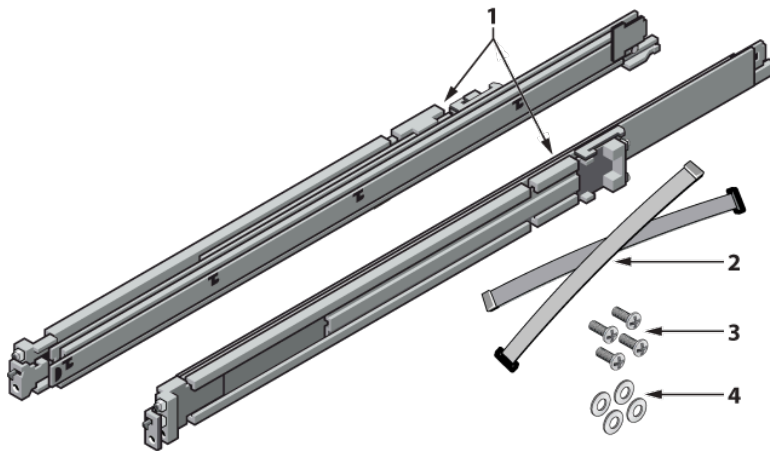

2. Installing and Removing Toolless Rails (Square Hole or Round Hole Racks).

- Position the left and right rail end pieces labeled FRONT facing inward and orient each end piece to seat in the holes on the front side of the vertical rack flanges (1).
- Align each end piece in the bottom and top holes of the desired U spaces (2).
- Engage the rail's back end until it fully sits on the vertical rack flange and the latch clicks into place. Repeat these steps to position and seat the front end piece on the vertical rack flange (3).
- Pull the latch release button on the end piece midpoint to remove the rails and unseat each rail (4).

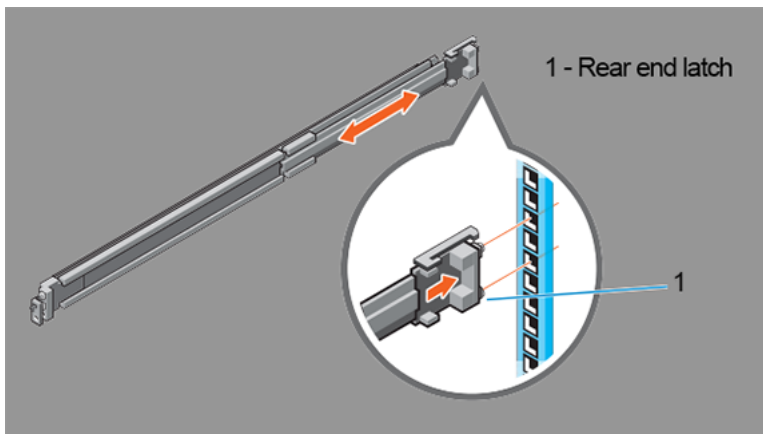

3. Installing and Removing Tooled Rails (Threaded Hole Racks).
 - a. Remove the pins from the front and rear mounting brackets using a flat-tipped screwdriver (1).
 - b. Pull and rotate the rail latch sub-assemblies to remove them from the mounting brackets (2).
 - c. Attach the left and right mounting rails to the front vertical rack flanges using two pairs of screws (3).
 - d. Slide the left and right back brackets forward against the rear vertical rack flanges and attach them using two pairs of screws (4).

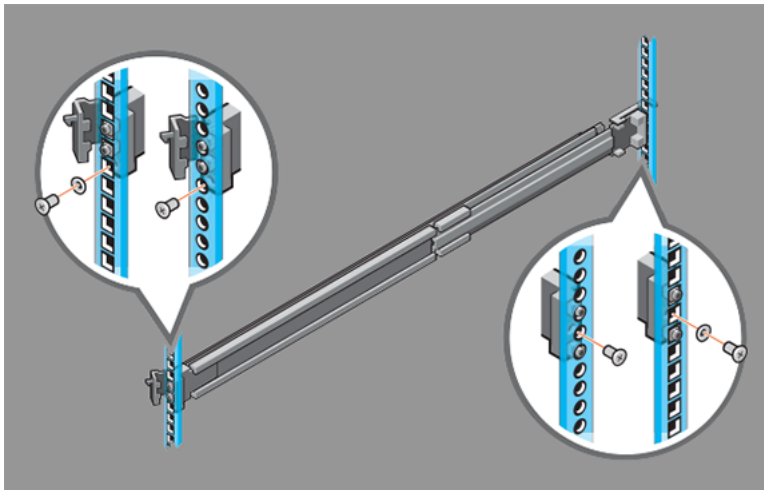

4. Installing the System in a Rack.
 - a. Pull the inner slide rails out of the rack until they lock into place (1).
 - b. Locate the rear rail standoffs on each side of the system and lower them into the rear J-slots on the slide assemblies (2).
 - c. Rotate the system downward until all the rail standoffs are seated in the J-slots (3).
 - d. Push the system inward until the lock levers click into place. Press the slide-release lock buttons on both rails and slide the system into the rack (4).

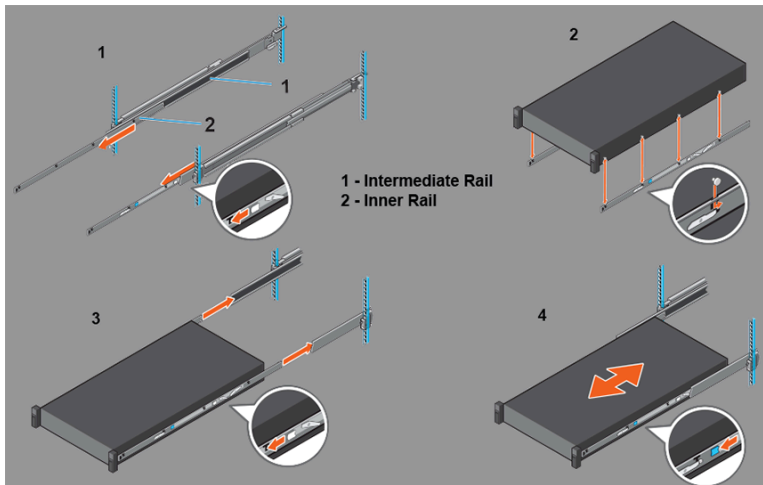

5. Removing the System From the Rack.

- a. Locate the lock levers on the sides of the inner rails (1).
- b. Unlock each lever by rotating it to its release position (2).
- c. Grasp the sides of the system firmly and pull it forward until the rail standoffs are at the front of the J-slots. Lift the system up and away from the rack and place it on a level surface (3).

6. Engaging and Releasing the Slam Latch.



Note: For systems not equipped with slam latches, secure the system using screws, as described in Step C of this procedure.

- a. Facing the front, locate the slam latch on either side of the system (1).
- b. The latches engage automatically as the system is pushed into the rack and are released by pulling up on the latches (2).
- c. To secure the system for shipment in the rack or other unstable environments, locate the hard-mount screw under each latch and tighten each screw with a #2 Phillips screwdriver (3).

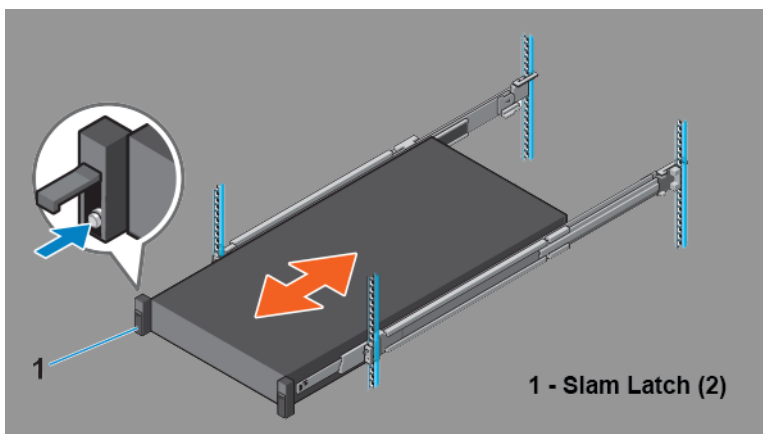

7. Routing the Cables.

- a. Locate the outer brackets on the interior sides of both rack flanges (1).
- b. Bundle the cables gently, pulling them from the system connectors to the left and right sides (2).

- c. Thread the hook and loop straps through the tool slots on the outer brackets on each side of the system to secure the cable bundles (3).

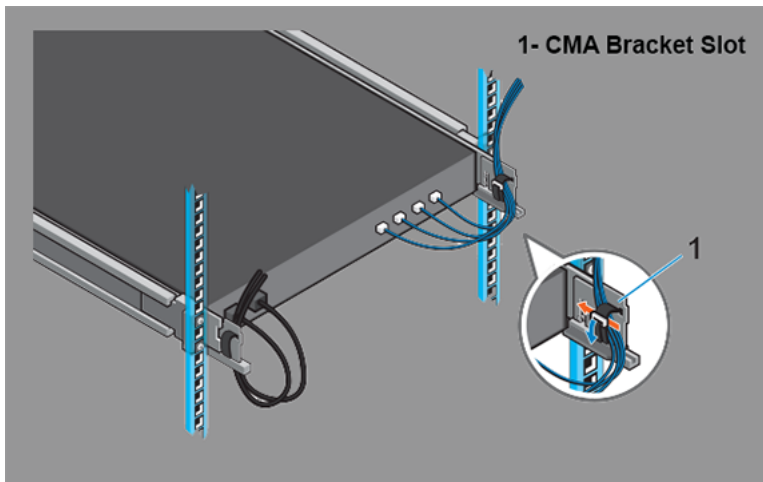

B.2 Two-Post Rack Mount Parts

The two-post rack mount kit includes:

- Two sliding rail assemblies.
- Two hook and loop straps.

Figure B-1: Two-Post Rack Mount Parts

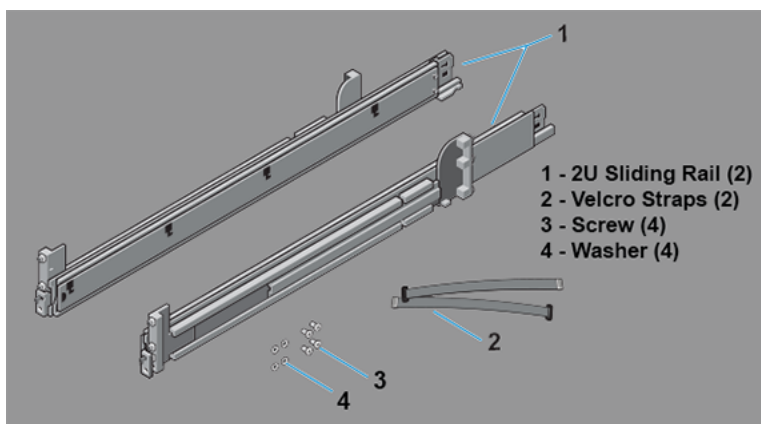

Front and Rear View of the System

Refer to the *DMF Service Node Specification* section in the *DMF Hardware Guide* document available at arista.com.

RoHS Declaration Statements

Figure D-1: Chinese RoHS Statement

用户须知

Arista Networks
产品信息《适用于中华人民共和国》

按照中华人民共和国电子行业标准 SJ/T11364-2014《电子电气产品有害物质限制使用标识》的要求，本文档提供相关产品信息。

表 1 列出了 Arista Networks 产品（包括部件）中超出 GB/T 26572 限制的有毒有害物质或元素。

| 部件名称 | 有毒有害物质和元素 | | | | | |
|---------|-----------|--------|--------|------------|------------|--------------|
| | 铅 (Pb) | 汞 (Hg) | 镉 (Cd) | 六价铬 (Cr6+) | 多溴联苯 (PBB) | 多溴联苯醚 (PBDE) |
| 金属外壳 | 0 | 0 | 0 | 0 | 0 | 0 |
| 印刷电路板组件 | X | 0 | 0 | 0 | 0 | 0 |
| 紧固件 | X | 0 | 0 | 0 | 0 | 0 |
| 电缆 | X | 0 | 0 | 0 | 0 | 0 |
| 安装硬件 | 0 | 0 | 0 | 0 | 0 | 0 |
| 线缆 | 0 | 0 | 0 | 0 | 0 | 0 |

O: 表示该部件的所有均质材料中的有毒有害物质含量低于 GB/T 26572 的限量值。
X: 表示该部件的所有均质材料中至少一种有毒有害物质含量高于 GB/T 26572 的限量值。

按照 GB/T 26572 的要求，Arista Networks 于中华人民共和国境内销售的所有产品均标有电子电气产品有害物质限制使用标识，以下标识适用于 Arista Networks 产品。

该标识说明，产品的某些均质材料中的有毒有害物质或元素含量超出 GB/T 26572 的限量值，已于表 1 列出这些物质。

某些产品由于尺寸或功能的限制，无法进行直接标记，这些产品也符合 SJ/T11364-2014 的要求，本文包含其标识信息。



上图所示的 20 指产品的环保使用年限 (EUP)。环保使用年限是指从生产日期开始，产品中的有毒有害物质或元素，在按照产品用户文档所述的正常使用条件下，不会发生泄漏或突变、对环境造成严重污染或对人身、财产造成严重损害的年代。

注：除中华人民共和国法律强制性规定中的明确要求外，Arista Networks 不对环保使用年限做任何明示或暗示的陈述或保证，并明确表示不对环保使用年限承担任何明示或暗示的陈述或保证。

For the Taiwan BSMI RoHS Table, go to <https://www.arista.com/assets/data/pdf/AristaBSMIRoHS.pdf>.