

ARISTA



QUICK START GUIDE

7800 Series Modular Data Center Switches

DCS-7804
DCS-7816

DCS-7808
DCS-7816L

DCS-7812



| Headquarters | Support | Sales |
|-------------------------------------------------------------------------------|------------------------------------------------------------|--------------------------------------------------------|
| 5453 Great America Parkway Santa Clara, CA 95054 USA +1-408-547-5500 | +1-408-547-5502 +1-866-476-0000 | +1-408-547-5501 +1-866-497-0000 |
| www.arista.com/en/ | support@arista.com | sales@arista.com |

© Copyright 2025 Arista Networks, Inc. All rights reserved. The information contained herein is subject to change without notice. The trademarks, logos, and service marks ("Marks") displayed in this documentation are the property of Arista Networks in the United States and other countries. Use of the Marks is subject to the Arista Networks Terms of Use Policy, available at www.arista.com/en/terms-of-use. Use of marks belonging to other parties is for informational purposes only.

Contents

- Chapter 1: Overview.....1**
 - 1.1 Scope..... 1
 - 1.2 Receiving and Inspecting the Equipment..... 1
 - 1.3 Installation Process..... 2
 - 1.4 Safety Information..... 3
 - 1.5 Obtaining Technical Assistance..... 3
 - 1.6 Specifications..... 3

- Chapter 2: Preparation.....9**
 - 2.1 Site Selection..... 9
 - 2.2 Tools and Parts Required for Installation..... 11
 - 2.3 Unpacking and Moving the Switch..... 12
 - 2.3.1 Unpacking and Moving the Switch (Example)..... 13
 - 2.4 Electrostatic Discharge (ESD) Precautions..... 15

- Chapter 3: Rack Mounting the Switch..... 17**
 - 3.1 DCS-7804, DCS-7808, DCS-7812, DCS-7816, and DCS-7816L Rack Mounting..... 17
 - 3.1.1 Inserting Rack Nuts Using the Template..... 17
 - 3.1.2 Inserting and Securing the Cradle Assembly..... 19
 - 3.1.3 Inserting the Switch into the Rack..... 22

- Chapter 4: Cabling the Modular Switch.....25**
 - 4.1 Cabling the Power Supplies..... 25
 - 4.2 Cabling Chassis Ground..... 27
 - 4.3 Cabling the AC Power Supplies..... 33
 - 4.4 Cabling the DC Power Supply..... 33
 - 4.4.1 DC Power Supplies..... 34
 - 4.4.2 Wire and Lug Preparation..... 34
 - 4.5 Power Supply Specifications..... 35
 - 4.6 Power Supply Configurations..... 36
 - 4.6.1 Recommendations for Power Supply Usage..... 36
 - 4.7 Power Supply Redundancy..... 36
 - 4.8 Connecting Supervisor Cables..... 38
 - 4.9 Connecting Linecard Modules and Cables..... 40

- Chapter 5: Configuring the Modular Switch.....41**

- Appendix A: Status Indicators.....43**
 - A.1 Supervisor Module..... 43
 - A.1.1 System Level Status Indicator LEDs: DCS-7800-SUP-D..... 43
 - A.2 Linecard Module Indicators..... 46
 - A.3 Fabric Module Status Indicators..... 47
 - A.4 Power Supply Status Indicators..... 49
 - A.4.1 PWR-D1-3041-AC-BLUE..... 49

| | |
|-----------------------------------------------------------|-----------|
| A.4.2 PWR-D2-3041-DC-BLUE..... | 50 |
| Appendix B: Parts List..... | 52 |
| B.1 Parts Used in All Rack Mount Configurations..... | 52 |
| B.1.1 Cables..... | 53 |
| B.1.2 Getting-Started Booklet..... | 53 |
| B.2 Four-Post Rack Mount Parts..... | 53 |
| | |
| Appendix C: Front Panel..... | 55 |
| | |
| Appendix D: Rear Panel..... | 60 |
| | |
| Appendix E: Linecards..... | 65 |
| | |
| Appendix F: Maintenance and Field Replacement..... | 67 |
| F.1 Linecard and Supervisor Extraction Tools..... | 67 |
| F.1.1 Assembling and Storing the Extraction Tools..... | 67 |
| F.2 Power Supplies..... | 68 |
| F.2.1 Removing AC Power Supply..... | 68 |
| F.2.2 Installing AC Power Supply..... | 69 |
| F.2.3 Removing DC Power Supply..... | 69 |
| F.2.4 Installing DC Power Supply..... | 69 |
| F.2.5 Removing Power Supply Blank..... | 70 |
| F.3 Fabric and Fan Module (Fabric Module)..... | 70 |
| F.3.1 Removing Fabric Module..... | 70 |
| F.3.2 Installing Fabric Module..... | 71 |
| F.4 Fan Module (within Fabric Module)..... | 73 |
| F.5 Supervisor Module..... | 75 |
| F.5.1 Removing Supervisor Module..... | 75 |
| F.5.2 Installing Supervisor Module..... | 75 |
| F.5.3 Removing Supervisor Module Blank..... | 75 |
| F.6 Linecards..... | 75 |
| F.6.1 Removing Linecard..... | 76 |
| F.6.2 Installing Linecard..... | 76 |
| F.6.3 Removing Linecard Blank..... | 76 |
| | |
| Appendix G: Regulatory Model Numbers..... | 77 |
| | |
| Appendix H: Taiwan RoHS Information..... | 78 |

Overview

This section discusses the following topics:

- [Scope](#)
- [Receiving and Inspecting the Equipment](#)
- [Installation Process](#)
- [Safety Information](#)
- [Obtaining Technical Assistance](#)
- [Specifications](#)

1.1 Scope

This guide is for properly trained service personnel and technicians who need to install the following Arista Networks Data Center Switches:

- DCS-7804
- DCS-7808
- DCS-7812
- DCS-7816
- DCS-7816L

Important: Only qualified personnel should install, service, or replace this equipment.



Seul le personnel qualifié doit installer, service, ou remplacer cet équipement.

1.2 Receiving and Inspecting the Equipment

Upon receiving the switch, inspect the shipping boxes and record any external damage. If you suspect that part of the shipment is damaged, retain packing materials; the carrier may need to inspect them.

If the boxes were not damaged in transit, unpack them carefully. Do not discard any accessories that may have been packaged in the same box as the main unit.

Inspect the packing list and confirm that you received all listed items. Compare the packing list with your DCS-7800 Series Modular Switches purchase order. The [Parts List](#) provides a list of components included with the switch.

1.3 Installation Process

Perform the following steps to install and use the switch:

1. Select and prepare the installation site ([Site Selection](#)).
2. Assemble the installation tools listed ([Tools and Parts Required for Installation](#)).
3. Attach the mounting brackets and install the switch in an equipment rack ([Rack Mounting the Switch](#)).
4. Connect the switch to the power source and network devices ([Cabling the Switch](#)).
5. Configure the switch ([Configuring the Switch](#)).

Important:

Class 1 Laser Product: This product has provisions for installing Class 1 laser transceivers that provide optical coupling to the communication network. Once a Class 1 laser product is installed, the equipment is a Class 1 Laser Product. The customer is responsible for selecting and installing the Class 1 laser transceiver and for ensuring that the Class 1 AEL (Allowable Emission Limit) per EN/IEC 60825, CSA E60825-1, and Code of Federal Regulations 21 CFR 1040 is not exceeded after the laser transceiver has been installed. Do not install laser products whose class rating is greater than 1. Refer to all safety instructions that accompany the transceiver before installation. Only Class 1 laser devices certified for use in the country of installation by the cognizant agency are to be utilized in this product.



Produit Laser de classe 1: Ce produit a des dispositions pour installer des émetteurs-récepteurs de laser de classe 1 qui offre de couplage au réseau de communication optique. Une fois un produit laser de classe 1 est installé, l'équipement est un produit Laser de classe 1 (Appareil à Laser de Classe 1). Le client est responsable pour sélectionner et installer l'émetteur/récepteur de laser de classe 1 et pour assurer que la classe 1 AEL (limite d'émission admissible) par EN/IEC 60825, CSA E60825-1, et Code des règlements fédéraux 21 CFR 1040 ne soit pas dépassée après avoir installé l'émetteur/récepteur de laser. Ne pas installer des appareils à laser dont la cote de classe est supérieure à 1. Voir toutes les consignes de sécurité qui ont accompagné l'émetteur-récepteur avant l'installation. Seuls appareils laser de classe 1 certifiés pour une utilisation dans le pays d'installation par l'organisme compétent doivent être utilisées dans ce produit.

Important:

Ultimate disposal of this product should be handled in accordance with all national laws and regulations.



L'élimination finale de ce produit doit être effectuée conformément à toutes les lois nationales et règlements.

1.4 Safety Information

Refer to the Arista Networks document *Safety Information and Translated Safety Warnings* at <https://www.arista.com/en/support/product-documentation>.

1.5 Obtaining Technical Assistance

Any customer, partner, reseller, or distributor holding a valid Arista Service Contract can obtain technical support in any of the following ways:

- **Email:** support@arista.com. Send an email to create a new service request.
Include a detailed description of the problem and the “show tech-support” output.

- **Web:** <https://www.arista.com/en/support>.

You can create a support case using the portal on our website. You can also download the most current software and documentation and view FAQs, Knowledge Base articles, Security Advisories, and Field Notices.

- **Phone:** +1 866-476-0000 or +1 408-547-5502.

Important:

There are no user-serviceable parts inside. Refer all servicing to qualified service personnel.



Aucune pièce réparable par l'utilisateur à l'intérieur. Confiez toute réparation à un technicien qualifié.

1.6 Specifications

The following table lists the specifications of Arista Data Center modular switches covered by this guide.

Table 1: Modular Switch Specifications

| | DCS-7804 | DCS-7808 | DCS-7812 | DCS-7816 | DCS-7816L |
|-------------------------------------|--------------------------------------------------------------------------------------------|--------------------------------------------------------------------------------------------|--------------------------------------------------------------------------------------------|--------------------------------------------------------------------------------------------|-------------------------------------|
| Height | 10 RU: 439 mm (17.28 inches) | 16 RU: 702 mm (27.64 inches) | 23 RU: 1012 mm (39.84 inches) | 32 RU: 1422 mm (55.98 inches) | 32 RU: 1422 mm (55.98 inches) |
| Width | 441 mm (17.36 inches) maximum | 441 mm (17.36 inches) maximum | 441 mm (17.36 inches) maximum | 441 mm (17.36 inches) maximum | 441 mm (17.36 inches) maximum |
| Depth | 940 mm (37.01 inches) | 940 mm (37.01 inches) | 940 mm (37.01 inches) | 1004 mm (39.52 inches) | 940 mm (37 inches) |
| Weight | 209.1 kg (460 lbs) fully loaded | 338.6 kg (745 lbs) fully loaded | 512.3 kg (1127 lbs) fully loaded | 717 kg (1580 lbs) fully loaded | 691 kg (1523 lbs) |
| DC Input (per PSU) | 2x -48 to -60 V DC70 A to 55 A | 2x -48 to -60 V DC 70 A to 55 A | 2x -48 to -60 V DC 70 A to 55 A | 2x -48 to -60 V DC 70 A to 55 A | 2x -48 to -60 V DC 70 A to 55 A |
| DC Branch Circuit Protection | 2x 90 A | 2x 90 A | 2x 90 A | 2x 90 A | 2x 90 A |
| AC Input Voltage (per PSU) | 2x 200-240 V | 2x 200-240 V | 2x 200-240 V | 2x 200-240 V | 2x 200-240 V |
| AC Branch Circuit Protection | 2x 20 A | 2x 20 A | 2x 20 A | 2x 20 A | 2x 20 A |
| Input Power Circuits | 6 to 8 circuits ⁽¹⁾ | 8 to 12 circuits ⁽²⁾ | 10 to 18 circuits ⁽³⁾ | 24 to 48 circuits ⁽⁴⁾ | |
| Ambient Temperature | 0° to 40°C (32° to 104°F) | 0° to 40°C (32° to 104°F) | 0° to 40°C (32° to 104°F) | 0° to 40°C (32° to 104°F) | |
| Storage Temperature | -40° to 70°C (-40° to 158°F) | -40° to 70°C (-40° to 158°F) | -40° to 70°C (-40° to 158°F) | -40° to 70°C (-40° to 158°F) | |
| Relative Humidity | 5 to 90% | 5 to 90% | 5 to 90% | 5 to 90% | |
| Altitude | 0 to 3,000 meters (0 to 10,000 feet) | 0 to 3,000 meters (0 to 10,000 feet) | 0 to 3,000 meters (0 to 10,000 feet) | 0 to 3,000 meters (0 to 10,000 feet) | |
| Cooling | See Power draw configurations in Table 2: 7800 Series Power Specifications | See Power draw configurations in Table 2: 7800 Series Power Specifications | See Power draw configurations in Table 2: 7800 Series Power Specifications | See Power draw configurations in Table 2: 7800 Series Power Specifications | |

1. For non-redundant power feeds, 12 to 16 for redundant power feeds.

2. For non-redundant power feeds, 16 to 24 for redundant power feeds.

3. For non-redundant power feeds, TBD for redundant power feeds.

4. For non-redundant power feeds, 24 to 48 for redundant power feeds.

The following table lists the power specifications of modular switch components.

Table 2: 7800 Series Power Specifications

| Module Type | Part Number | Power Draw (Typical / Maximum) |
|---------------------------|--------------------|--------------------------------|
| Supervisor Modules | DCS-7800-SUP | 61 W / 72 W |
| | DCS-7800-SUP1A | 61 W / 72 W |
| | DCS-7800-SUP1S | 61 W / 72 W |
| | DCS-7816-SUP1A | 71 W / 78 W |
| | DCS-7816-SUP1S | 71 W / 78 W |
| Linecard Modules | DCS-7800R3-48CQ | 398 W / 462 W |
| | DCS-7800R3K-48CQ | 398 W / 462 W |
| | DCS-7800R3K-72Y | 142 W / 178 W |
| | DCS-7800R3-48CQM | 620 W / 684 W |
| | DCS-7800R3-48CQ2 | 474 W / 622 W |
| | DCS-7800R3-48CQM2 | 511 W / 696 W |
| | DCS-7800R3-48CQMS | 501 W / 666 W |
| | DCS-7800R3-36P | 825 W / 1136 W |
| | DCS-7800R3A-36P | 533 W / 749 W |
| | DCS-7800R3A-36PM | 548 W / 764 W |
| | DCS-7800R3AK-36PM | 578 W / 794 W |
| | DCS-7800R3-36D | 839 W / 1149 W |
| | DCS-7800R3A-36D | 533 W / 749 W |
| | DCS-7800R3A-36DM | 548 W / 764 W |
| | DCS-7800R3AK-36DM | 578 W / 794 W |
| | DCS-7800R3K-36DM | 1416 W / 1823 W |
| | DCS-7800R3A-36D2 | 563 W / 779 W |
| | DCS-7800R3A-36DM2 | 578 W / 794 W |
| | DCS-7800R3AK-36DM2 | 608 W / 824 W |

| Module Type | Part Number | Power Draw (Typical / Maximum) |
|---------------------------|---------------------------------------------------------------------------------------------------------------------------------------|--------------------------------|
| Fabric Modules | DCS-7804R3-FM | 180 W / 248 W |
| | DCS-7808R3-FM | 510 W / 778 W |
| | DCS-7808R3-FM2 | 370 W / 518 W |
| | DCS-7812R3-FM | 681 W / 917 W |
| | DCS-7816R3-FM | 510 W / 778 W |
| | DCS-7816LR3-FM | 510 W / 778 W |
| Power Supply (AC) | PWR-D1-3041-AC-BLUE | 3 W / 10 W ⁽¹⁾ |
| Power Supply (DC) | PWR-D2-3041-DC-BLUE | 3 W / 10 W ⁽¹⁾ |
| 7804 Series System | Full chassis loaded with: 2 - DCS-7800-SUP1A 6 - DCS-7804R3-FM 4 - DCS-7800R3-48CQ 6 - PWR-D1-3041-AC-BLUE | 3310 W / 4397 W |
| 7808 Series System | Full chassis loaded with: 2 - DCS-7800-SUP1A 6 - DCS-7808R3-FM 8 - DCS-7800R3-48CQ 8 - PWR-D1-3041-AC-BLUE | 6390 W / 8540 W |
| 7812 Series System | Full chassis loaded with: 2 - DCS-7816-SUP1A 6 - DCS-7812R3-FM 12 - DCS-7800R3-48CQ2 10 PWR-D1-3041-AC-BLUE | 12490 W / 14788 W |
| 7816 Series System | Full chassis loaded with: 2 - DCS-7816-SUP1A 12 - DCS-7816R3-FM 16 - DCS-7800R3-48CQ 24 - PWR-D1-3041-AC-BLUE | 12881 W / 17150 W |

| Module Type | Part Number | Power Draw (Typical / Maximum) |
|---------------------|---------------------------------------------------------------------------------------------------------------------------------------|--------------------------------|
| 7816L Series System | Full chassis loaded with: 2 - DCS-7816-SUP1A 6 - DCS-7816LR3-FM 16 - DCS-7800R3-48CQ 24 - PWR-D1-3041-AC-BLUE | |

¹ With no input power.

Note ¹ Includes typical power supply conversion inefficiency. Contact your local Sales Engineer for 7800 power calculator details.

Note ² Power numbers are given as Typical/Maximum or Typical/Hot/Maximum where Hot is defined as 40°C Sea Level.

* Not N+N redundant power at worst case Temp/Elevation.

Preparation

This section discusses the following topics:

- [Site Selection](#)
- [Tools and Parts Required for Installation](#)
- [Unpacking and Moving the Switch](#)
- [Electrostatic Discharge \(ESD\) Precautions](#)

2.1 Site Selection

When selecting a site to install the switch, consider the following criteria:

- **Floor Space:** Install the switch in an area that provides adequate clearance for removing front and rear components.

The [Figure 2-1: Clearance Requirements and Footprint for Switches](#) display the dimensions and footprint of the switch clearance requirements.

Figure 2-1: Clearance Requirements and Footprint for Switches

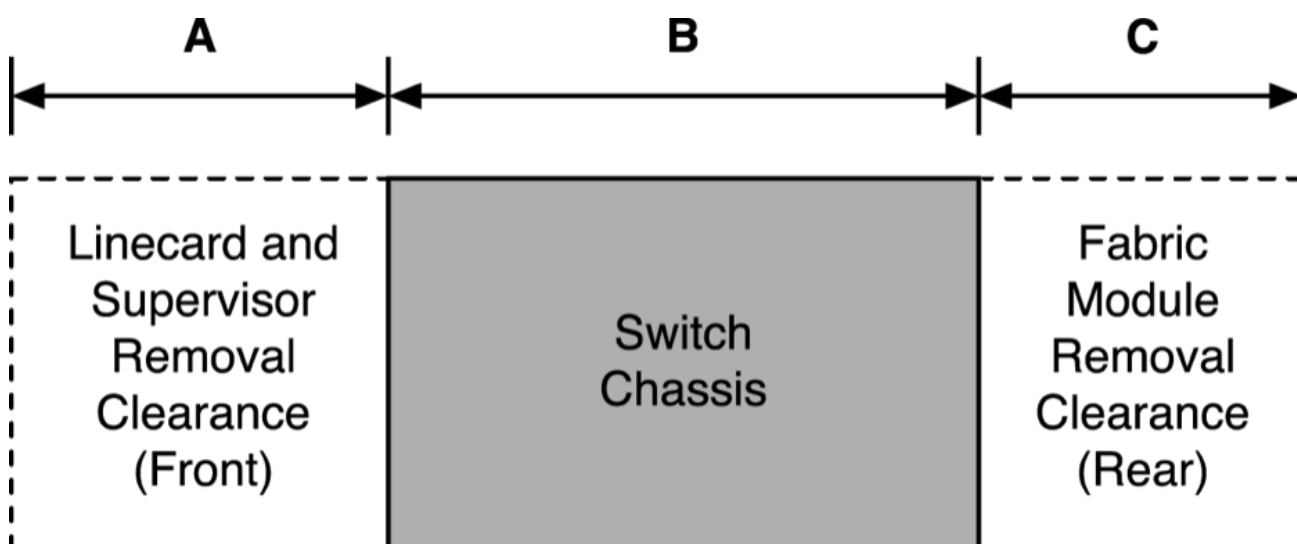

The [Figure 2-1: Clearance Requirements and Footprint for Switches](#) display the dimensions and footprint of the switch clearance requirements.

Table 3: Clearance Requirements and Footprint Dimensions

| Switch | Clearance Requirements Dimensions | | |
|-----------|-----------------------------------|---------------------|--------------------|
| | A | B | C |
| DCS-7804 | 38.4 cm (15.1 in.) | 102.1 cm (40.2 in.) | 58.9 cm (23.2 in.) |
| DCS-7808 | 38.4 cm (15.1 in.) | 102.1 cm (40.2 in.) | 58.9 cm (23.2 in.) |
| DCS-7812 | 38.4 cm (15.1 in.) | 102.1 cm (40.2 in.) | 58.9 cm (23.2 in.) |
| DCS-7816 | 38.4 cm (15.1 in.) | 102.1 cm (40.2 in.) | 58.9 cm (23.2 in.) |
| DCS-7816L | 38.4 cm (15.1 in.) | 102.1 cm (40.2 in.) | 58.9 cm (23.2 in.) |

 **Note:** The PSU removal clearance (Front) is 62.5 cm (24.6 in.)

- **Temperature and Ventilation:** For proper ventilation, install the switch with ample airflow to the front and back of the switch. The temperature should not go below 0° or exceed 40°C.

Important:
 To prevent the switch from overheating, do not operate it in an area where the ambient temperature exceeds 40°C (104°F).

 Pour empêcher l'interrupteur de surchauffe, ne pas utiliser il dans une zone où la température ambiante est supérieure à 40°C (104°F).

- **Airflow Orientation:** The fans direct air from the front panel to the rear panel. Orient the front panel toward the cool aisle.
- **Rack Space Requirements:** The [Table 4: Rack Space Requirements](#) table shows the rack space requirements for each modular switch.

Table 4: Rack Space Requirements

| Switch | Rack or Cabinet (standard 19" EIA) | | |
|----------|------------------------------------|--------|--------------------|
| | 2-Post | 4-Post | Switch Height (RU) |
| DCS-7804 | No | Yes | 10 |
| DCS-7808 | No | Yes | 16 |
| DCS-7812 | No | Yes | 23 |
| DCS-7816 | No | Yes | 32 |



Note: The accessory kit provides the required mounting hardware for each switch.

- **Power Requirements:** Arista switches require a minimum number of operating AC or DC power supplies in all chassis and for each power domain of switches with multiple power domains. Refer to [Cabling the Power Supplies](#) for more details regarding your switch.

Important:

DC cables should be protected with circuit over-current protection devices and circuit disconnect means. To turn off a unit, power must be disconnected from ALL power cables.



DC câbles doivent être protégés avec dispositifs de protection de surintensité circuit et moyens de déconnexion du circuit. Pour éteindre une unité, l'alimentation doit être débranchée de TOUS les câbles d'alimentation.

- **Other Requirements:** Select a site where liquids or objects cannot fall onto the equipment and foreign objects are not drawn into the ventilation holes. Ensure these guidelines are met:
 - Clearance areas to the front and rear panels allow for unrestricted cabling.
 - All front and rear panel indicators can be easily read.
 - AC power cords can reach the input connectors from the AC power outlet.
 - DC power cables can reach the input connectors from the DC power distribution unit.

2.2 Tools and Parts Required for Installation

The following tools are required to install a modular switch.

- A mechanical device capable of lifting the chassis being installed ([Table 1: Modular Switch Specifications](#)).
- Torque reading nut driver (for DC power supplies).
- #2 Phillips head screwdriver.



Note: Switch shipments include a template to assist with rack mounting.

Rack Mount

The [Table 5: Rack Component Requirements](#) table shows the rack components required for each modular switch.

Table 5: Rack Component Requirements

| Switch | Rack or Cabinet (standard 19" EIA) | | |
|-----------|------------------------------------|--------------------------|---------------------|
| | Rack Screws ⁽¹⁾ | Rack Nuts ⁽²⁾ | Notes |
| DCS-7804 | 21 ⁽³⁾ | 21 ⁽³⁾ | 4-post installation |
| DCS-7808 | 21 ⁽³⁾ | 21 ⁽³⁾ | 4-post installation |
| DCS-7812 | 27 ⁽³⁾ | 27 ⁽³⁾ | 4-post installation |
| DCS-7816 | 35 ⁽³⁾ | 35 ⁽³⁾ | 4-post installation |
| DCS-7816L | 35 ⁽³⁾ | 35 | 4-post installation |

¹ The accessory kit includes screws that fit many common equipment racks.

² Rack nuts are only for racks with unthreaded rack-post holes.

³ These are in addition to the rack-mount kit screws required for the cradle.

2.3 Unpacking and Moving the Switch

The DCS-7816 accessory kit includes bolts and lifting brackets ([Figure 2-2: Lifting Brackets](#)) that must be attached to the top of the chassis with the bolts supplied for lifting the chassis from the pallet onto the transport lift. You can use any appropriate lifting mechanism/tool to unload the switch. A platform lift is recommended for the transportation and installation of the switch. The rack mounting cradle is shipped nested upside down over the top of the chassis for all switches ([Figure 2-3: Cradle and Switch](#)). A protective film on the top and sides keeps the cradle from scratching the chassis during transport.

 **Note:** The DCS-7812 accessory kit includes bolts and lifting brackets that must be similarly attached. The illustrations highlight the DCS-7816.

Figure 2-2: Lifting Brackets

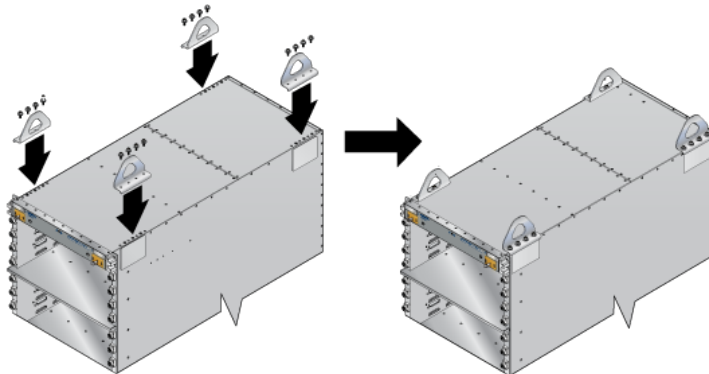
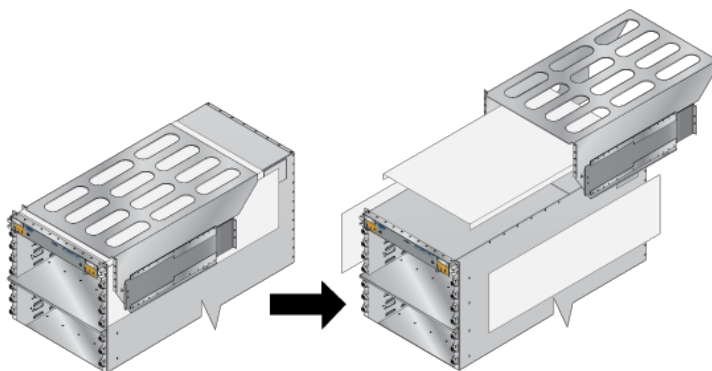

Figure 2-3: Cradle and Switch

2.3.1 Unpacking and Moving the Switch (Example)

The example illustrates the de-palletizing and transportation of a DCS-7816 chassis using the following:

- 1000 lb lifting straps
 - Server Lift SL-1000X® Super-Duty Lift
 - 1000 lb capacity
 - Battery-operated and motorized
 - Integrated rollers with lockout

The DCS-7816 chassis ships on an engineered pallet, as shown below.



1. Cut away the straps and remove the cardboard to expose the chassis with the rack kit basket attached and nested on top of the chassis.



2. From the accessory kit shipped with the chassis, remove and attach the lifting brackets to the top of the chassis.

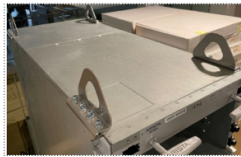

3. Attach the 1000 lb lifting straps to the lifting brackets on the chassis and the loops through the prongs of the lift.



4. Place the chassis on the transport lift (Server Lift SL-1000X® Super-Duty Lift) with the lift platen in the neutral position and the chassis aligned for moving into the rack.



Note: Populate the chassis with linecards and fabric modules only after insertion into the rack.

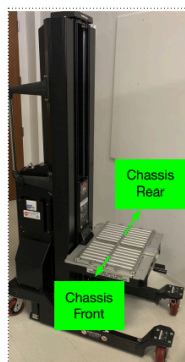

5. Align and move the chassis into the rack using the translatable platen.



Note: Use the built-in, foot-pedal actuated lock to secure the lift while sliding the chassis into the rack.



Note: Before moving the chassis into the rack, attach the cradle to the rack ([DCS-7804](#), [DCS-7808](#), [DCS-7812](#), [DCS-7816](#), and [DCS-7816L Rack Mounting](#)).



2.4 **Electrostatic Discharge (ESD) Precautions**

Observe these guidelines to avoid ESD damage when installing or servicing the switch.

- Assemble or disassemble equipment only in a static-free work area.
- Select a conductive work surface (such as an anti-static mat) to dissipate static charge.
- Wear an ESD wrist strap to dissipate static charge accumulation.
- Minimize handling of assemblies and components.
- Keep replacement parts in their original static-free packaging.
- Remove all plastic, foam, vinyl, paper, and other static-generating materials from the work area.
- Select tools that do not create ESD.

Rack Mounting the Switch

This section discusses the following topics:

- [DCS-7804, DCS-7808, DCS-7812, DCS-7816, and DCS-7816L Rack Mounting](#)
 - [Inserting Rack Nuts Using the Template](#)
 - [Inserting and Securing the Cradle Assembly](#)
 - [Inserting the Switch into the Rack](#)

3.1 DCS-7804, DCS-7808, DCS-7812, DCS-7816, and DCS-7816L Rack Mounting

The accessory kit provides components for installing the switch in four-post racks. The accessory kit includes the following four-post mounting parts:

- Cradle assembly
- M6 pan-head Phillips screws
- M6 rack cage nuts (optional)
- Template for non-threaded racks requiring rack nuts



Note: Two-post rack mount is not supported.

Illustrations in this chapter depict the mounting of an unpopulated 8-slot chassis.

After completing the instructions for your rack type, proceed to [Cabling the Power Supplies](#).

Perform the following tasks to mount the switch in a four-post rack:

- Insert rack nuts (for racks requiring them) at appropriate locations. ([Inserting Rack Nuts Using the Template](#)).
- Insert and secure the cradle assembly into the rack ([Inserting and Securing the Cradle Assembly](#)).
- Insert the switch into the rack ([Inserting the Switch into the Rack](#)).

3.1.1 Inserting Rack Nuts Using the Template

Note: Required only for non-threaded racks that use rack nuts. Installation is referenced with the bottom screw located at the 1RU location. For a different starting point for the bottom screw, always start at an RU location, and ensure there is enough room for your device in the rack.

1. Attach the template supplied with your switch to the front left post so that the top and bottom locations for the rack nuts line up with the RU locations required by your device.
2. Insert rack-mount nuts required by the switch ([Table 6: Rack Mount Locations and Screws Required by Switch](#)) at the locations identified by the [Figure 3-1: Rack Nut Locations](#) using the template.

Note: The number of rack nuts required for the front left and front right rack posts is different. The rear posts require the same number (4 each).

Figure 3-1: Rack Nut Locations

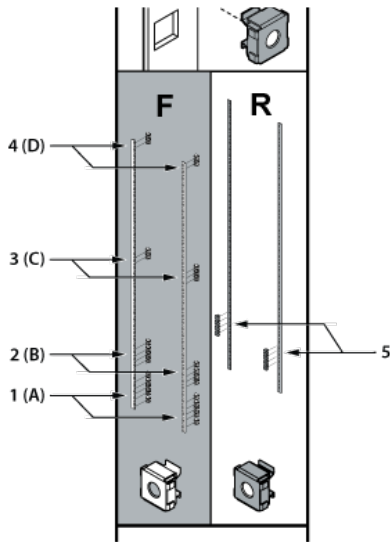

- | | |
|----------------------------------------------|----------------------------------------------|
| 1 Mounting location A Front (Left and Right) | 4 Mounting location D Front (Left and Right) |
| 2 Mounting location B Front (Left and Right) | 5 Mounting location Rear (Left and Right) |
| 3 Mounting location C Front (Left and Right) | |

Table 6: Rack Mount Locations and Screws Required by Switch

| Mounting Location | DCS-7804 | | DCS 7808 | | DCS-7812 | | DCS-7816 | |
|-------------------|-----------|-----------|-----------|-----------|-----------|-----------|-----------|-----------|
| | Front (L) | Front (R) | Front (L) | Front (R) | Front (L) | Front (R) | Front (L) | Front (R) |
| A | 5 | 5 | 5 | 5 | 5 | 5 | 5 | 5 |
| B | N/A | N/A | N/A | N/A | 3 | 3 | 4 | 4 |
| C | N/A | N/A | N/A | N/A | N/A | N/A | 2 | 3 |
| D | 1 | 2 | 1 | 2 | 1 | 2 | 2 | 2 |

1. Rear post locations are indicated by the template and are used for securing the cradle.

3.1.2 Inserting and Securing the Cradle Assembly

Insert and secure the cradle assembly to the rack using the following steps.



Note: The rack mounting cradle is shipped nested upside down over the top of the chassis for all switches. A protective film on the top and sides prevents the cradle from scratching the chassis during transport.

1. Insert two screws loosely in the two front rack posts at the same level and two in the back two rack posts 3 RU above the front screws ([Figure 3-2: Attaching Mounting Screws to the Rack Posts](#)). Use the template for racks requiring rack nuts ([Figure 3-3: Mounting \(Starting Screws\) Locations for Cradle \(Front and Rear\)](#)). The front locations are marked with single dots, and the rear locations with two dots.

Figure 3-2: Attaching Mounting Screws to the Rack Posts

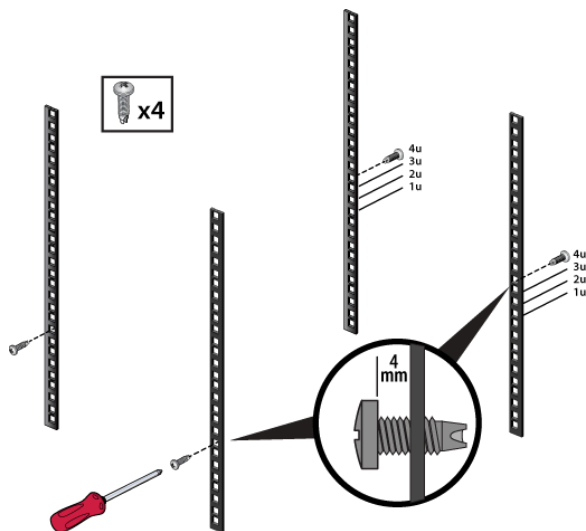
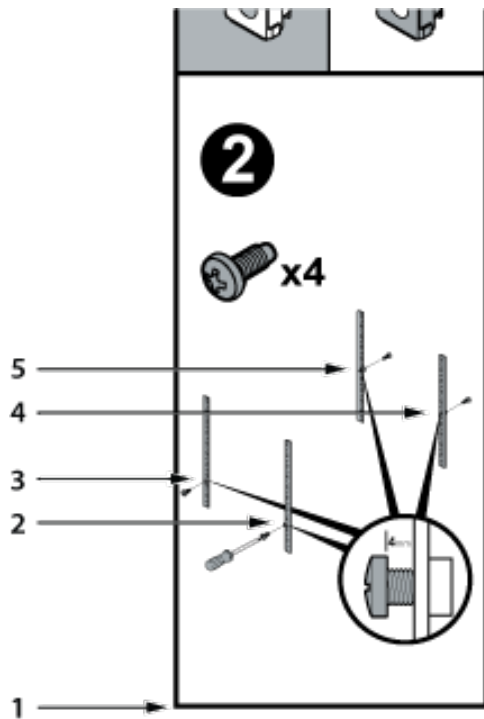

Figure 3-3: Mounting (Starting Screws) Locations for Cradle (Front and Rear)



- | | |
|-----------------------|----------------------|
| 1 Bottom of switch | 4 Rear Screw (Left) |
| 2 Front screw (Right) | 5 Rear Screw (Right) |
| 3 Front Screw (Left) | |

2. Prior to installation, buckle the straps on the cradle together so the left and right sides are angled slightly inwards.

Figure 3-4: Buckling the Straps

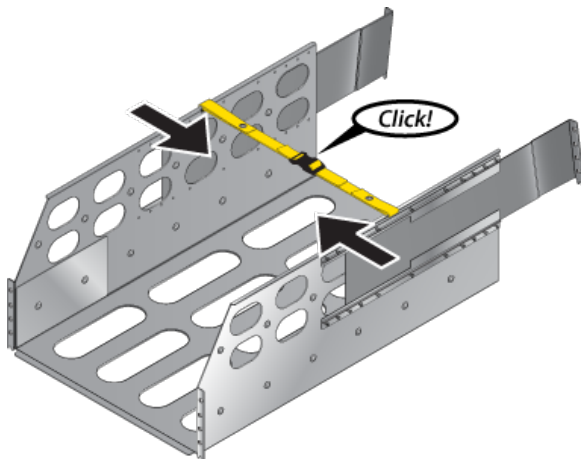

3. Pull out the rear sliding rails slightly beyond the back rack posts.

4. Insert the cradle so that the notches in the cradle engage behind the loosely mounted front screws.
5. Slide the rear sliding rails back in so that they are flush with the back rack posts, the notches in the cradle engage behind the loosely mounted screws, and the bottom of the cradle is horizontal and level.

Figure 3-5: Inserting the Cradle

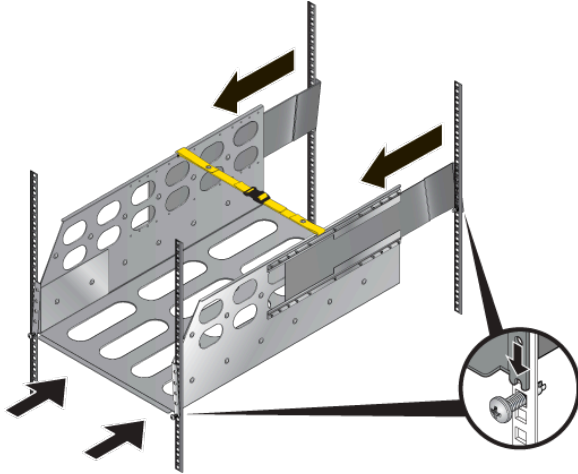

6. Release the clasp on the connector to rotate the left and right sides so they are vertical.

Figure 3-6: Aligning the Cradle in the Rack

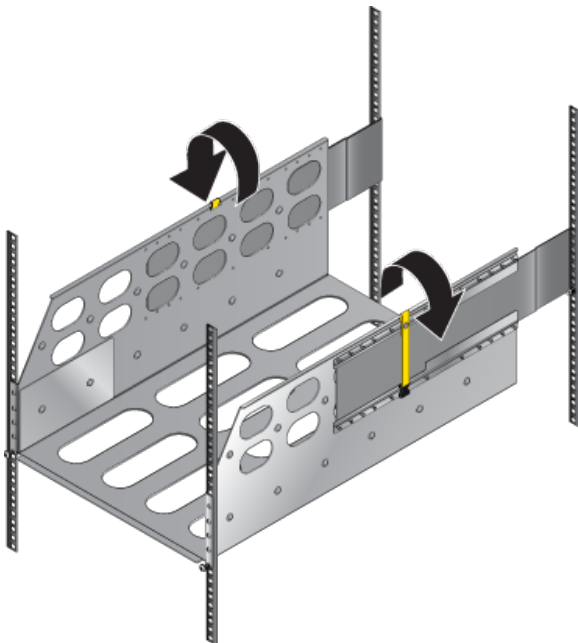

7. Secure the cradle to the rack posts using the eight remaining screws, two more in the front and six more in the back, for a total of twelve screws.

Figure 3-7: Securing the Cradle in the Rack

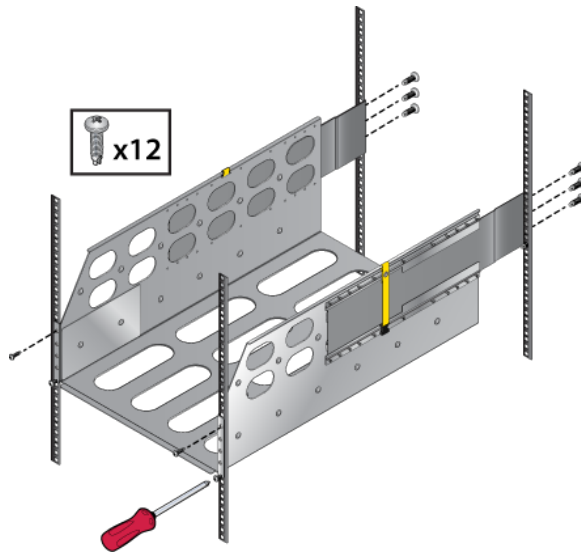

3.1.3 Inserting the Switch into the Rack

Mount the switch onto a four-post rack by assembling a rack-mount cradle into the rack. Then, place the switch on the cradle and secure it to the rack.

1. Move the chassis to the rack using a mechanical lift.



Note: If modules are inserted into the chassis, use the lift carefully to avoid damaging any components.

2. Lift the chassis and insert it into the rack. For the DCS-7816 chassis, remove the lifting brackets from the top of the chassis, which are required to lift the chassis from the pallet onto a transport lift before insertion.



Note: A platform lift is recommended for transportation and installation.

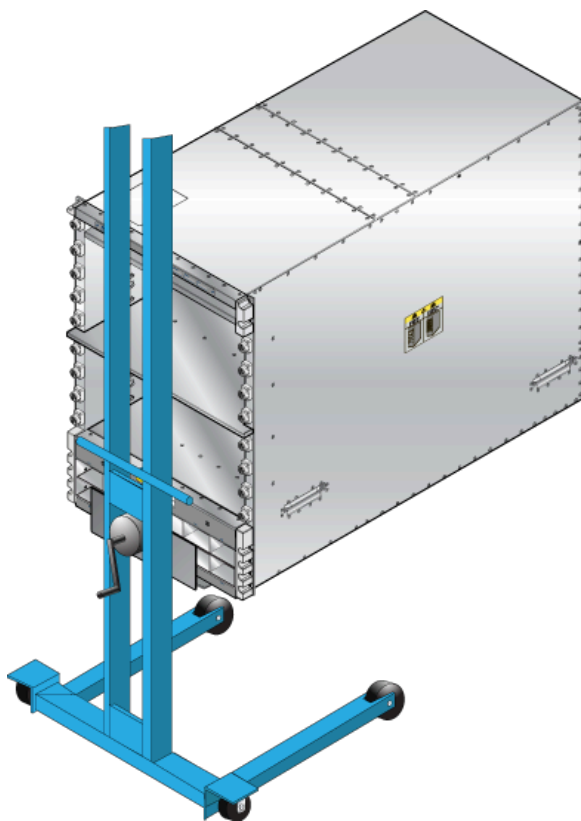

Note: Rack space permitting, it is recommended that the lifting brackets remain attached to the switch after it is secured in the rack.

Figure 3-8: Lifting the Chassis

3. Secure the chassis by tightening additional M6 screws on the front flanges into the rack posts.



Note: Additional screws depend on the device. The 7804 and 7808 chassis require nine.

Figure 3-9: Secure the Switch to the Rack Shelf

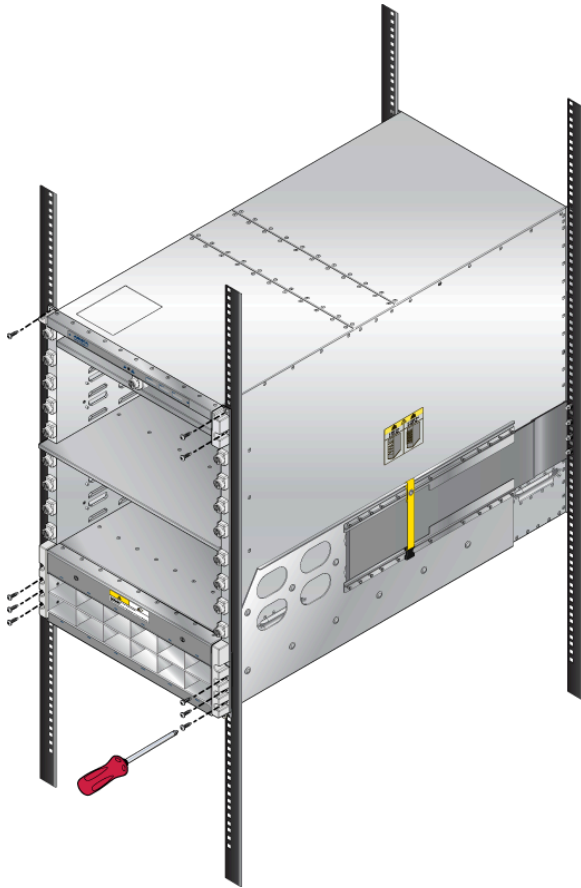

4. After completing the Four-Post Installation, proceed to [Cabling the Power Supplies](#).

Cabling the Modular Switch

This section discusses the following topics:

- [Cabling the Power Supplies](#)
- [Cabling Chassis Ground](#)
- [Cabling the AC Power Supplies](#)
- [Cabling the DC Power Supply](#)
- [Power Supply Specifications](#)
- [Power Supply Configurations](#)
- [Power Supply Redundancy](#)
- [Connecting Supervisor Cables](#)
- [Connecting Linecard Modules and Cables](#)

4.1 Cabling the Power Supplies

Before you begin, refer to the Arista Networks document *Compliance and Safety Guide*, available at <https://www.arista.com/en/support/product-documentation>.



Note: Power supplies may be loaded in the PSU bays in any order. The following order is recommended for each switch covered by this guide.

Table 7: Recommended PSU Bay Population Order

| Switch | Order |
|----------|---------------------------------------------------------------------------------------|
| DCS-7804 | 8, 7, 6, 5, 4, 3, 2, 1 |
| DCS-7808 | 6, 12, 5, 11, 4, 10, 3, 9, 2, 8, 1, 7 |
| DCS-7812 | 9, 18, 8, 17, 7, 16, 6, 15, 5, 14, 4, 13, 3, 12, 2, 11, 1, 10 |
| DCS-7816 | 8, 16, 24, 7, 15, 23, 6, 14, 22, 5, 13, 21, 4, 12, 20, 3, 11, 19, 2, 10, 18, 1, 9, 17 |

The following figure shows the recommended order. A blank (X) should be placed on all unpopulated bays.

DCS-7804



DCS-7808



DCS-7812

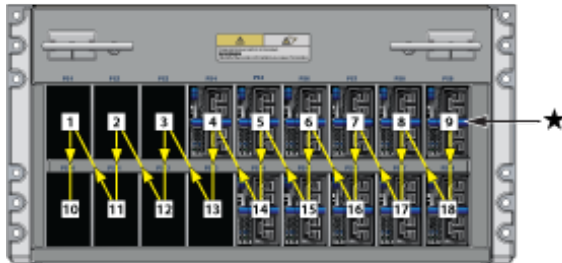

DCS-7816

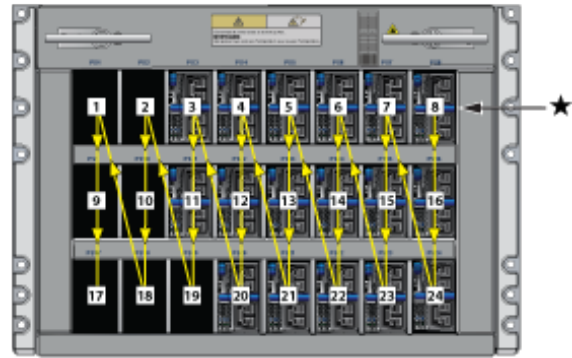

Note: '*' designates the recommended starting bay.

Important:

Power down the switch. Remove all power cords from the power inlets.



Mettez le commutateur: Retirez tous les cordons d'alimentation des prises d'alimentation.

Important:

The installation of this equipment must comply with local and national electrical codes. Consult with the appropriate regulatory agencies and inspection authorities to ensure compliance if necessary.



Installation de cet équipement doit être conformes aux codes électriques locaux et nationaux. Si nécessaire, consulter les organismes de réglementation appropriés et des autorités de contrôle pour assurer la conformité.



Note:

Many configurations will require additional power supplies.

Nombreuses configurations exigera des alimentations supplémentaires.

Important:

All power supply slots must be filled with either a power supply or blank to ensure proper airflow.



Tous les emplacements d'approvisionnement de puissance doivent être remplis avec une alimentation ou vide pour assurer un débit d'air appropriée.

Important:

Read all installation instructions before connecting the system to the power source.



Lire toutes les instructions d'installation avant de brancher le système à la source d'alimentation.

[Power Supply Configurations](#) show each switch's minimum number of operating power supplies connected to active circuits.

Each power supply includes a fan that maintains proper power supply temperature. The appendices display the location of components for all switches described in this guide.

4.2 Cabling Chassis Ground



Note: This section applies only to +48VDC input installations. A bonding wire from the chassis to the rack and/or the data center ground is optional for AC input installations.

[Figure 4-1: Front Panel \(DCS-7804\)](#), [Figure 4-2: Front Panel \(DCS-7808\)](#), [Figure 4-3: Front Panel \(DCS-7812\)](#), and [Figure 4-4: Front Panel \(DCS-7816\)](#) display the location of the chassis grounding locations on the front panel of the switches. Additional grounding locations are on the rear panel of the switch chassis. After mounting the switch into the rack, connect at least one of the chassis grounds to the data center ground using two-hole ground lugs with 16 mm (5/8 in.) spacing and two M4 x 0.7 screws. After the switch is grounded, ESD wrist straps can be grounded by connecting them to one of the attach points.

Important:



Grounding wires and grounding lugs are not supplied. Wire size should meet local and national installation requirements. Commercially available 2 or 4 AWG wire is recommended for installations in the U.S.

À la terre et de mise à la terre fils cosses ne sont pas fournis. Calibre des fils doit satisfaire des exigences de l'installation locale et nationale. Disponible dans le commerce 2 ou 4 AWG fil est recommandé pour les installations aux États-Unis.

Important:

This equipment must be grounded. Never defeat the ground conductor. This unit requires over-current protection.



Cet équipement doit être mis à la terre. Ne jamais modifier le conducteur de terre. Cet appareil nécessite de protection contre les surintensités.

Important:

Secondary Grounding wires, lugs, and screws (M4 x 0.7) are not supplied.



Secondaire à la terre, câbles, cosses et vis (M4 x 0.7) ne sont pas fournis.

Figure 4-1: Front Panel (DCS-7804)

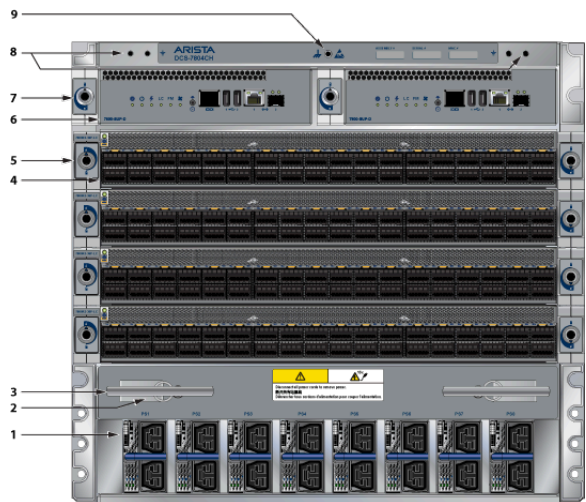

- | | | |
|--------------------------------------------------|----------------------|-----------------------|
| 1 Power supplies | 4 Linecards | 7 Supervisor lock |
| 2 Linecard and Supervisor extraction tool tether | 5 Linecard lock | 8 Grounding locations |
| 3 Extraction tool | 6 Supervisor modules | 9 ESD attach point |

Figure 4-2: Front Panel (DCS-7808)

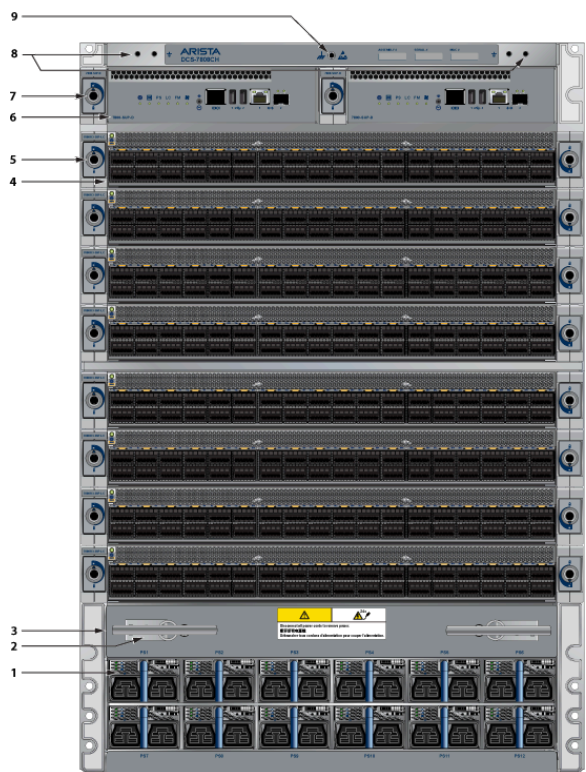

1 Power supplies

2 Linecard and Supervisor extraction tool tether

3 Extraction tool

4 Linecards

5 Linecard lock

6 Supervisor modules

7 Supervisor lock

8 Grounding locations

9 ESD attach point

Figure 4-3: Front Panel (DCS-7812)

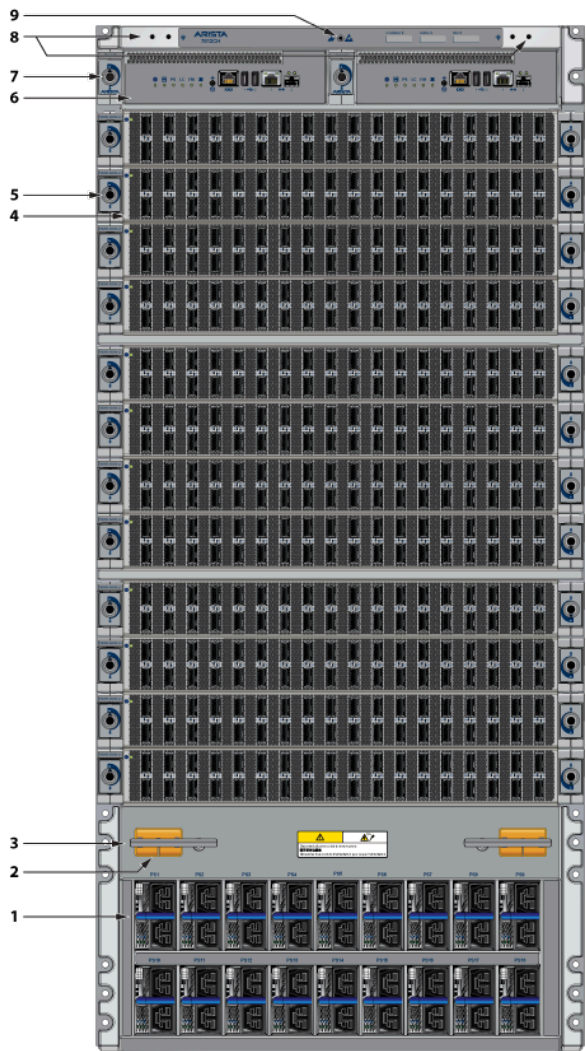

- | | | |
|--------------------------------------------------|----------------------|-----------------------|
| 1 Power supplies | 4 Linecards | 7 Supervisor lock |
| 2 Linecard and Supervisor extraction tool tether | 5 Linecard lock | 8 Grounding locations |
| 3 Extraction tool | 6 Supervisor modules | 9 ESD attach point |

Figure 4-4: Front Panel (DCS-7816)

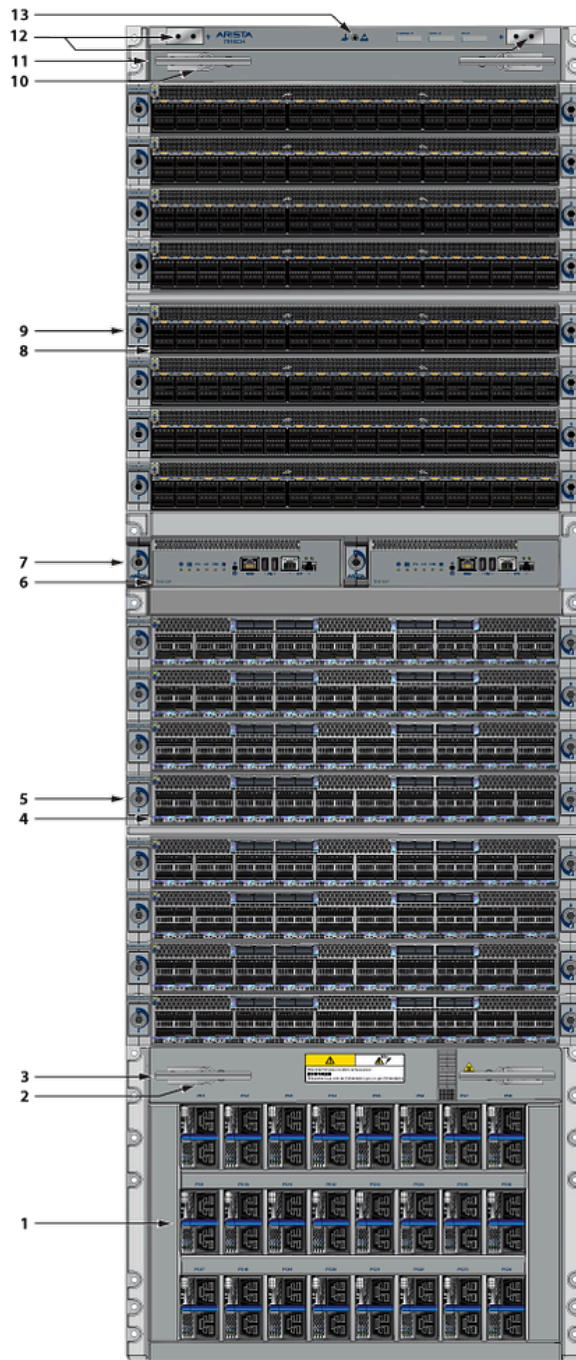

- | | | |
|--------------------------------------------------|---------------------------------------------------|------------------------|
| 1 Power supplies | 6 Supervisor modules | 11 Extraction tool |
| 2 Linecard and Supervisor extraction tool tether | 7 Supervisor lock | 12 Grounding locations |
| 3 Extraction tool | 8 Linecards | 13 ESD attach point |
| 4 Linecards | 9 Linecard lock | |
| 5 Linecard lock | 10 Linecard and Supervisor extraction tool tether | |

Figure 4-5: Front Panel (DCS- 7816L)

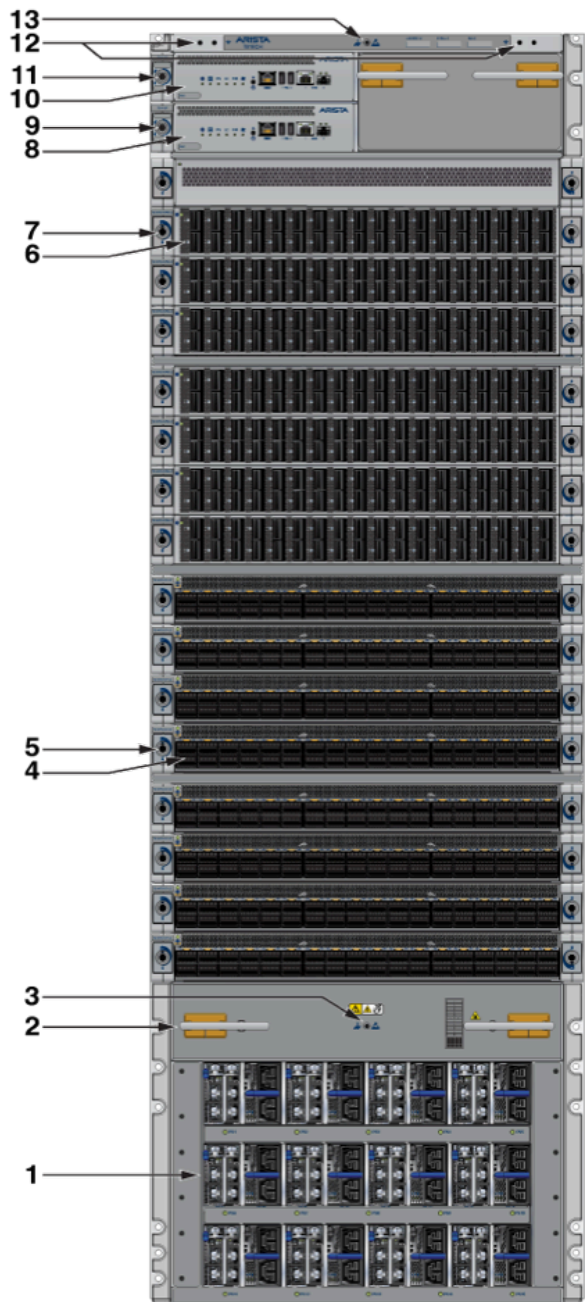

- | | | |
|--------------------------------------------------|----------------------|------------------------|
| 1 Power supplies | 6 Linecard | 11 Supervisor lock |
| 2 Linecard and Supervisor extraction tool tether | 7 Linecard lock | 12 Grounding locations |
| 3 Extraction tool | 8 Supervisor module | 13 ESD attach point |
| 4 Linecard | 9 Supervisor lock | |
| 5 Linecard lock | 10 Supervisor module | |



Note: Remove all power cords from the power inlets to turn off the switch.

4.3 Cabling the AC Power Supplies

The switches use PWR-D1-3041-AC-BLUE (Figure 4-6: AC Power Supply) power supplies with SAF-D-GRID connectors on the PSU inputs. Power cables are included with the accessory kit (Table 16: Accessory Kits for the Modular Switches). To power the switch, insert the other side of the cable into the main power-providing circuit.



Note: The power supply, handle color, orientation, etc., may differ from the one shown on your device in Figure 4-6: AC Power Supply.

Figure 4-6: AC Power Supply

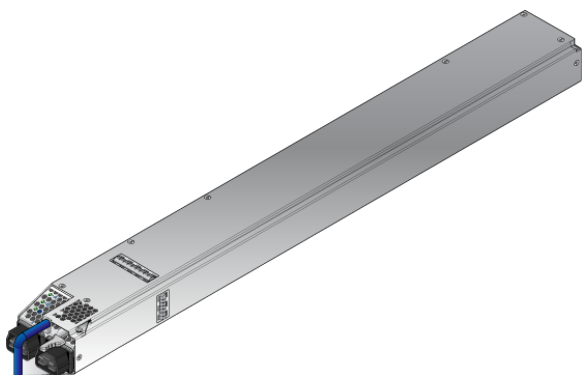

The [Front Panel](#) displays the front panel location of the power supplies.



Note:

- The LEDs on a PSU remain lit even after you disconnect the power and remove the PSU from the chassis. They will eventually turn off in a short while.
- The PWR-D1-3041-AC-BLUE PSU uses 2x 220 V supply inputs and uses 2 APP SAF-D-GRID 400 connectors.

4.4 Cabling the DC Power Supply



Note: The -48V and Battery-Return leads are a pair and should run adjacent and be approximately the same length.

Le - 48V et câbles de batterie-retour sont une paire courir à côté de l'autre et doivent être à peu près la même longueur.

4.4.1 DC Power Supplies

The switches support the PWR-D2-3041-DC-BLUE DC power supply displayed in [Figure 4-7: PWR-D2-3041-DC-BLUE Power Supplies](#).

Figure 4-7: PWR-D2-3041-DC-BLUE Power Supplies

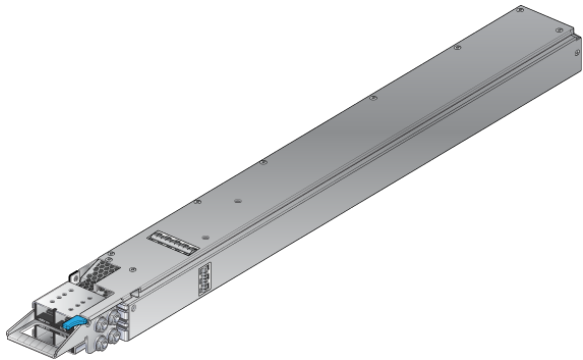

Note: Release lever color indicates airflow direction.

4.4.2 Wire and Lug Preparation

Remove power from DC circuits by turning off the power line servicing the circuits before installing. Prepare the stranded wiring before you begin a DC power installation.

1. Stranded copper wiring is required.
 - Commercially available 1 to 2 AWG wire is recommended for installations in the U.S.
 - Wire size should meet local and national installation requirements.
 - Grounding wires and grounding lugs are not supplied.
 - Strip the wires to the appropriate length for the lugs.

The wires connecting the DC power supply to the power source must meet the following requirements:

- DC Input Wire Size: 1– 2 AWG.
- Primary Ground Wire Size: 1– 2 AWG per power supply.
- The conductors are copper.

2. Use agency-approved compression (pressure) lugs for wiring terminations (2x - Two M6 studs with 5/8" spacing).
3. Slip on heat-shrink tubing on the wire ends before assembling the lugs onto the wire.
 - The lugs must be crimped with the proper tool.
 - The tubing should extend over the lug's barrel and the wire's insulator.
4. Shrink the tubing with a heat gun.

Figure 4-8: Lugs Wiring Terminations

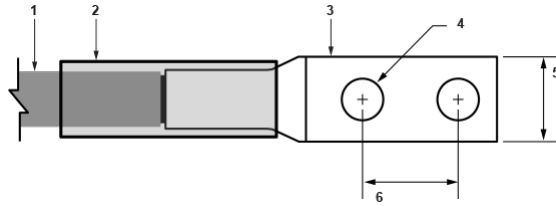

1 Insulated wire

2 Heat-shrink tubing

3 Lug

4 Quarter-inch diameter hole

5 Half-inch width

6 Five-eighth-inch apart centers

4.5 Power Supply Specifications

The [Table 8: Power Supply Specifications \(each PSU\)](#) shows the power supply specifications for each of the PSUs supported.

Table 8: Power Supply Specifications (each PSU)

| Power Supply | Maximum Output Power Rating (DC) | Input Voltage and Frequency | Maximum Input Current | Input Branch Circuit Protection |
|---------------------|----------------------------------|-----------------------------------------------|-----------------------|---------------------------------|
| PWR-D1-3041-AC-BLUE | 3000 W | 200 to 240 VAC(nominal) 50/60 Hz (nominal) | 2x 16 A | 2x 20 A |
| PWR-D2-3041-DC-BLUE | 3000 W | -48 V to -60 VDC, 70 A to 55A | 2x 70 A | 2x 90 A |

Important:

Each power supply requires input branch circuit protection in compliance with AHJ requirements.



Chaque alimentation nécessite une protection du circuit de la branche d'entrée conformément aux exigences de l'AHJ.

4.6 Power Supply Configurations

The following table shows the power supply configurations for the modular switches.

Table 9: Power Supply Configurations

| Modular Switch | Number of PSUs Shipped in Bundle | Maximum Number of PSUs Supported |
|----------------|----------------------------------|----------------------------------|
| DCS-7804 | 6 | 8 |
| DCS-7808 | 8 | 12 |
| DCS-7812 | 10 | 18 |
| DCS-7816 | 12 | 24 |

4.6.1 Recommendations for Power Supply Usage

- Use separate circuits (A and B) to protect each power supply.
- When replacing a failed PSU, use the same PSU model. If the original model is no longer supported or available, an alternative PSU must be approved before use.
- Only mix power supply types if your switch allows mixing power supplies.
- To minimize distribution power loss, use an equal number of supplies in each row (e.g., 4 PSUs in slots 1-4 and 4 PSUs in slots 7-10 for a configuration with 8 PSUs for the DCS-7808 switch). [Cabling the Power Supplies](#) provides more details.



Note: The DCS-7808 switch can house PSUs in either of two rows. The LEDs for PSUs in each row indicate correct status only after at least one of the PSUs in that row (PSU1 to PSU6 or PSU7 to PSU12) is energized from a power source. For the DCS-7812 and DCS-7816 switches, all PSU LEDs will report status correctly as long as one PSU is powered.

- All power supply slots must be filled with a powered supply, a blank (X), or a non-powered power supply.
- Valid redundancy configurations for each domain are described in [Power Supply Redundancy](#).

4.7 Power Supply Redundancy



Important:

The installation of this equipment must comply with local and national electrical codes. Consult with the appropriate regulatory agencies and inspection authorities to ensure compliance if necessary.

Installation de cet équipement doit être conformes aux codes électriques locaux et nationaux. Si nécessaire, consulter les organismes de réglementation appropriés et des autorités de contrôle pour assurer la conformité.

Important:

Read all installation instructions before connecting the system to the power source.



Lire toutes les instructions d'installation avant de brancher le système à la source d'alimentation.

Most installations will have redundant, dual, independent power feeds. Each independent power feed will be referenced as A and B.

The recommended installation is to wire input_A and input_B of each supply to an independent power feed (A or B).



Note: When powered cables are connected to both A and B inputs of the PSU, the AC PSU will draw current from the A input. The B input is held in standby. The DC PSU will share power based on the input voltage.

Each power supply includes a fan that maintains proper power supply temperature. The appendices display the location of the components on all switches described in this guide.

The [Front Panel](#) displays the front panel location of the supervisor modules, linecards, and PSUs.

The [Rear Panel](#) displays the rear panel location of fabric modules.

Important:

This unit requires over-current protection.



Cet appareil nécessite de protection contre les surintensités.

Important:

Unused slots must be occupied or covered with a blank to ensure proper airflow through the chassis.

Les emplacements inutilisés doivent être occupés ou recouvert d'un blanc pour assurer la bonne circulation d'air dans le châssis.

4.8 Connecting Supervisor Cables

Supervisor modules contain console, management, and USB ports. [Figure 4-9: Supervisor DCS-7800-SUP, DCS-7800-SUP1A, and DCS-7816-SUP](#) display port and status LED locations on the supervisors. For additional information about the serial port, refer to the chassis specification in [Figure 4-10: DCS-7808 Supervisor Slots](#).

Figure 4-9: Supervisor DCS-7800-SUP, DCS-7800-SUP1A, and DCS-7816-SUP

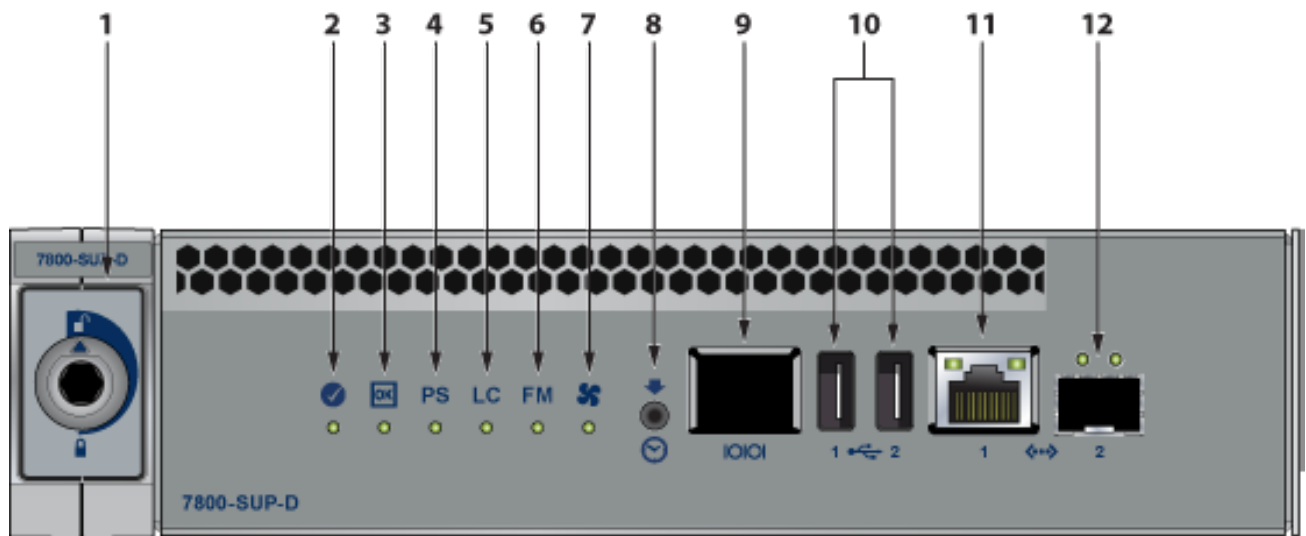

- | | | |
|--------------------------------|----------------------------|-----------------------------------|
| 1 Locking mechanism | 5 Linecard status LED | 9 RJ-45 Serial management port |
| 2 Supervisor status LED | 6 Fabric Module status LED | 10 USB Ports |
| 3 Supervisor active status LED | 7 Fan status LED | 11 RJ-45 Ethernet management port |
| 4 PSU status LED | 8 Clock In | 12 SFP Ethernet management port |

- **Console (Serial) Port:** Connect to a PC with RJ-45 to DB-9 serial adapter cable. Default switch settings include:
 - 9600 baud
 - No flow control
 - 1 stop bit
 - No parity bits
 - 8 data bits

The appropriate supervisor cards must be installed in one of the designated slots. They are shown in [Figure 4-10: DCS-7808 Supervisor Slots](#) for the DCS-7808 switch. For the DCS-7816 switch, the supervisor slots are in the middle of the chassis.

Figure 4-10: DCS-7808 Supervisor Slots

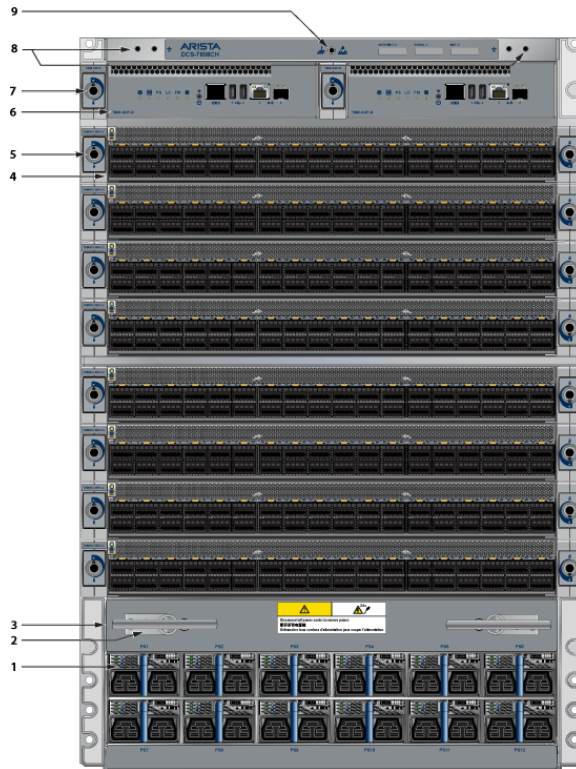

- | | | |
|--------------------------------------------------|----------------------|-----------------------|
| 1 Power supplies | 4 Linecards | 7 Supervisor lock |
| 2 Linecard and Supervisor extraction tool tether | 5 Linecard lock | 8 Grounding locations |
| 3 Extraction tool | 6 Supervisor modules | 9 ESD attach point |

RJ-45 to DB-9 Connections

| RJ-45 | | DB-9 | | RJ-45 | | DB-9 | |
|-------|---|------|-----|-------|---|------|-----|
| RTS | 1 | 8 | CTS | GND | 5 | 5 | GND |
| DTR | 2 | 6 | DSR | RXD | 6 | 3 | TXD |
| TXD | 3 | 2 | RXD | DSR | 7 | 4 | DTR |
| GND | 4 | 5 | GND | CTS | 8 | 7 | RTS |

- **Ethernet management port:** Connect to 10/100/1000 management network with RJ-45 cable.
- **USB Port:** This may be used for software or configuration updates.
- **Clock Input Port:** The port type is MCX connector, 2-5.5V, 50 ohm termination.

4.9 Connecting Linecard Modules and Cables

Install required SFP, SFP+, QSFP+, QSFP100, OSFP, and QSFP-DD optic modules in linecard module ports (Figure 4-11: SFP or SFP+ Ports).

Figure 4-11: SFP or SFP+ Ports



Connect cables as required to linecard module ports. Supervisor and linecard module ejectors on the front of the chassis assist with cable management.

CAUTION:

Excessive bending can damage interface cables, especially optical cables.



Flexion excessive peut endommager les câbles d'interface, en particulier les câbles optiques.



Note: You must ensure that the appropriate “blank” plates cover any open slots for modules, power supplies, etc. Check with your local Arista Networks representative if you have questions.

Configuring the Modular Switch

Arista switches ship from the factory in Zero Touch Provisioning (ZTP) mode. ZTP configures the switch without user intervention by downloading a startup configuration file or a boot script from a location specified by a DHCP server. To manually configure a switch, ZTP is bypassed. The initial configuration provides one username (**admin**) that is accessible only through the console port because it has no password.

When bypassing ZTP, initial switch access requires logging in as **admin**, with no password, through the console port. Then, you can configure an **admin** password and other password-protected usernames.

This manual configuration procedure cancels ZTP mode, logs into the switch, assigns a password to the **admin**, assigns an IP address to the management port, and defines a default route to a network gateway.

1. Provide power to the switch ([Cabling the Power Supplies](#)).
2. Connect the console port to a PC.

As the switch boots without a **startup-config** file, it displays this message through the console:

```
The device is in Zero Touch Provisioning mode and is attempting to
download the startup-config from a remote system. The device will not
be fully functional until either a valid startup-config is downloaded
from a remote system or Zero Touch Provisioning is cancelled. To cancel
Zero Touch Provisioning, login as admin and type 'zerotouch cancel'
at the CLI.

localhost login:
```

3. Log into the switch by typing **admin** at the login prompt.

```
localhost login: admin
```

4. Cancel ZTP mode by typing **zerotouch cancel**.

 **Important:** This step initiates a switch reboot.

```
localhost> zerotouch cancel
```

5. After the switch boots, log into the switch again by typing **admin** at the login prompt.

```
Arista EOS
localhost login: admin
Last login: Fri Mar 15 13:17:13 on console
```

6. Enter global configuration mode.

```
localhost> enable
```

```
localhost# config
```

7. Assign a password to the **admin** username with the **username secret** command.

```
localhost (config)# username admin secret pxq123
```

8. Configure a default route to the network gateway.

```
localhost (config)# ip route 0.0.0.0/0 192.0.2.1
```

9. Assign an IP address (**192.0.2.8/24** in this example) to an Ethernet management port.

```
localhost (config)# interface management 1/1  
localhost (config-if-Ma1/1)# ip address 192.0.2.8/24
```

10. Save the configuration by typing **write memory** or **copy running-config startup-config**.

```
localhost# copy running-config startup-config
```

11. When the management port IP address is configured, select this command to access the switch from a host using the address configured in **Step 9**:

```
ssh admin@192.0.2.8
```

Refer to the *Arista Networks User Manual* for the complete switch configuration information.

Status Indicators

This section discusses the following topics:

- [Supervisor Module](#)
- [Linecard Module Indicators](#)
- [Fabric Module Status Indicators](#)
- [Power Supply Status Indicators](#)

A.1 Supervisor Module

While the front panel of each switch can house two supervisors, switch operations require only one. Supervisors display switch status and contain Ethernet management and console ports. The supervisor provides:

- One serial console port.
- Two Ethernet management ports (one RJ-45, one optical.)
- Two USB ports.
- One clock input port.
- Several system-level status indicator LEDs (see [System Level Status Indicator LEDs: DCS-7800-SUP-D.](#))

A.1.1 System Level Status Indicator LEDs: DCS-7800-SUP-D

The system status indicator LEDs are shown in [Figure A-1: Supervisor DCS-7800-SUP-D.](#)

Figure A-1: Supervisor DCS-7800-SUP-D

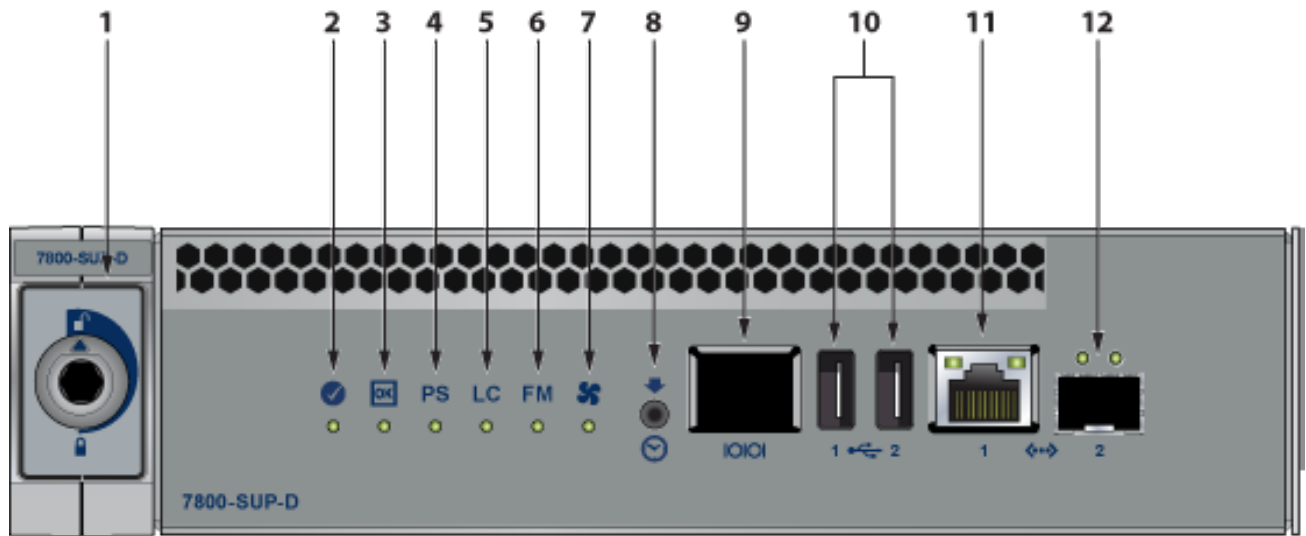

- | | | |
|--------------------------------|----------------------------|-----------------------------------|
| 1 Locking mechanism | 5 Linecard status LED | 9 RJ-45 Serial management port |
| 2 Supervisor status LED | 6 Fabric Module status LED | 10 USB Ports |
| 3 Supervisor active status LED | 7 Fan status LED | 11 RJ-45 Ethernet management port |
| 4 PSU status LED | 8 Clock In | 12 SFP Ethernet management port |

Supervisor Status LEDs

[Supervisor Status LED States](#) interprets the states of the supervisor status LEDs for both the active and the redundant supervisor modules.

Table 10: Supervisor Status LED States

| Supervisor and System Condition ⁽¹⁾ | LED Name and State | | | | | | | |
|------------------------------------------------------------------------------------------------------------------------|--------------------|--------|--------------------|---------------|--------------------|------------|---------------|------------------|
| | Status | Active | Power Supply (PSU) | Linecard (LC) | Fabric Module (FM) | Fan Module | Ethernet Port | |
| | | | | | | | Link (Left) | Activity (Right) |
| No power, failed, or improperly inserted. | Off | Off | Off | Off | Off | Off | Off | Off |
| Booting | Blinking Green | Off | Off | Off | Off | Off | Off | Off |
| Beacon Request Locate | Blue | Off | Off | Off | Off | Off | Off | Off |
| Normal Active Operation (Master Supervisor) System Status: Good | Green | Green | Green | Green | Green | Green | (2) | (2) |
| Redundant Supervisor (Active-Standby) Status: Good | Green | Off | Off | Off | Off | Off | Off | Off |
| Forced fail-over to redundant supervisor (Not active) Status: Bad | Red | Off | Off | Off | Off | Off | Off | Off |
| Supervisor active and operating normally; No PSUs, LCs, FMs, or Fan Modules present or powered | Green | Green | Off | Off | Off | Off | Off | Off |
| Supervisor active, Status: PSU failure (one or more) - no AC input, DC output, Over current or not enough PSUs present | Green | Green | Red | (3) | (3) | (3) | (2) | (2) |
| Supervisor active, Status: LC failure (one or more) | Green | Green | (3) | Red | (3) | (3) | (2) | (2) |
| Supervisor active, Status: FM failure (one or more) | Green | Green | (3) | (3) | Red | (3) | (2) | (2) |
| Supervisor active, Status: Fan Module failure (one or more) or not present | Green | Green | (3) | (3) | (3) | Red | (2) | (2) |
| Supervisor active, Ethernet port linked with activity | Green | Green | (3) | (3) | (3) | (3) | Green | Green |
| Supervisor active, Ethernet port linked with no activity | Green | Green | (3) | (3) | (3) | (3) | Green | Off |
| Supervisor active, Ethernet port not linked | Green | Green | (3) | (3) | (3) | (3) | Off | Off |

¹ Assumes a redundant supervisor is present.

² Depends on port operation.

³ Green for normal operation, red if no corresponding component is powered or present.



Note: Arista modular switches take 15 to 30 minutes to boot completely.

A.2 Linecard Module Indicators

Each linecard module provides one status LED plus LEDs for each port on the card. [Linecard Status LED](#) shows a representative linecard. The figures in [linecards](#) indicate the location of the LEDs on each linecard.

Figure A-2: Linecard Status LED

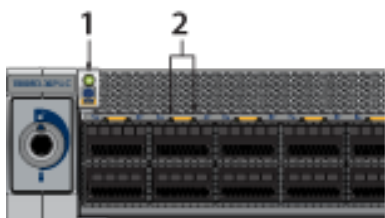

- 1 Linecard status LED
- 2 Port status LED

[Linecard Status LED States](#) interprets the states of the status LED.

Table 11: Linecard Status LED States

| LED State | Status |
|-----------------------|----------------------------------------------------|
| Off | Linecard not inserted. |
| Green | Linecard operating normally. |
| Yellow (amber/orange) | Linecard administratively shut down or booting up. |
| Red | Linecard has failed. |
| Red (blinking) | Locator function is enabled. |

The linecard provides LEDs for each port module socket:

- Each LED corresponds to a module.
- A set of four LEDs correspond to each module. The first LED in the set reports status when the module is programmed as a 40G port. When the module is programmed as four 10G or 100G ports, each port is assigned to an LED within the set.
- For linecards that support OSFP and QSFP-DD ports with one LED per port, [Linecard Port LED States](#) interpret the port LED states.

Table 12: Linecard Port LED States

| LED State | Status |
|--------------------------------|-----------------------------------------------|
| Off | Port link is down for all enabled interfaces. |
| Green | Port link is up for any enabled interface. |
| Yellow (amber/orange) | Port is disabled in the software. |
| Flashing yellow (amber/orange) | Locator function is enabled on an interface. |

A.3 Fabric Module Status Indicators

Fabric Status LEDs are on fan-fabric modules. The [Rear Panel](#) displays the position of these modules on the rear of each switch. The following figure displays the fan status and fabric status LEDs on the DCS-7804 switch. [Figure A-5: DCS-7808R3-FM and DCS-7816R3-FM Fabric Module and Fan Status LEDs](#) display fan status and fabric status LEDs on the DCS-7808 and DCS-7816 switches.

 **Note:** The fabric modules are installed vertically in the chassis. They are shown horizontally in the following illustrations. The exact location of the LEDs in your system could be different from those shown.

Figure A-3: DCS-7804R3-FM Fabric Module and Fan Status LEDs



- | | | |
|----------------------------|---------------------------|---------------------------|
| 1 Fabric module top | 3 Fan module 1 status LED | 5 Fan module 3 status LED |
| 2 Fabric module status LED | 4 Fan module 2 status LED | 6 Fan module 4 status LED |

The following figure displays the LEDs for the fan status and fabric status on the DCS-7812 switch.

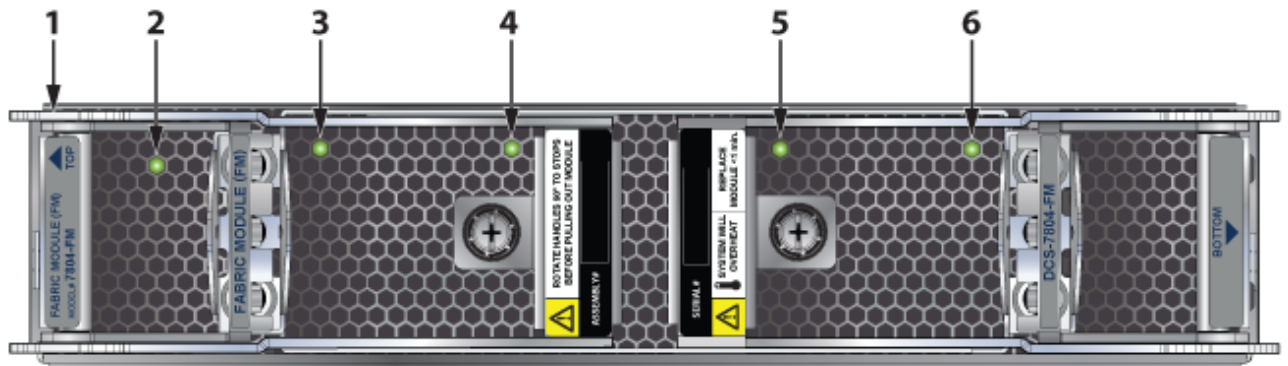
Figure A-4: DCS-7812R3-FM Fabric Module

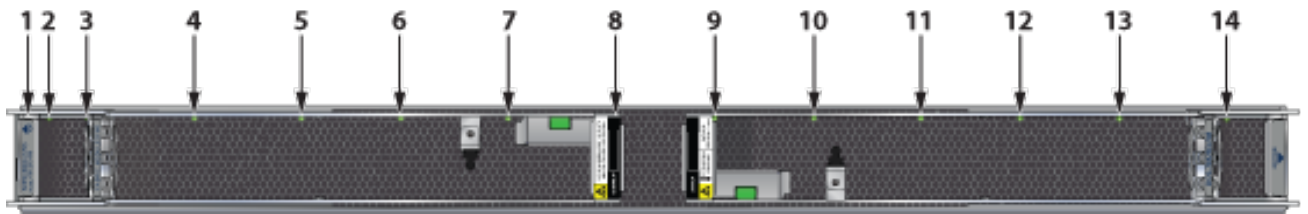

- | | | |
|----------------------------|-------------------------------|-----------------------------|
| 1 Fabric module top | 6 Fan module 4 status LED | 11 Fan module 8 status LED |
| 2 Fabric module status LED | 7 Fan module 5 status LED | 12 Fan module 9 status LED |
| 3 Fan module 1 status LED | 8 Fan module 6 status LED | 13 Fan module 10 status LED |
| 4 Fan module 2 status LED | 9 Fabric module ejector lever | 14 Fan module 11 status LED |
| 5 Fan module 3 status LED | 10 Fan module 7 status LED | |

Figure A-5: DCS-7808R3-FM and DCS-7816R3-FM Fabric Module and Fan Status LEDs

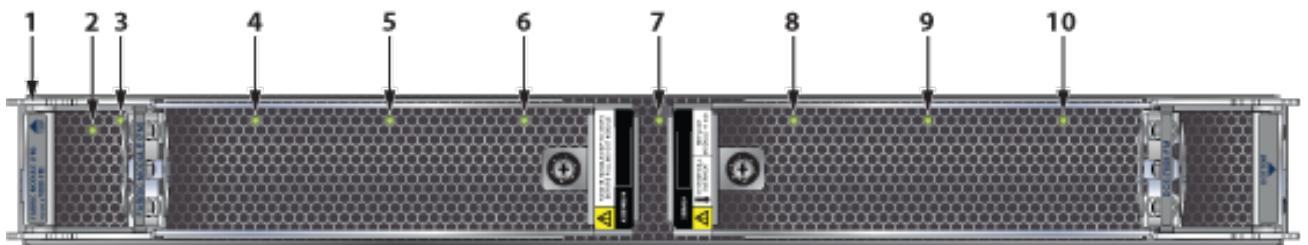

- | | | |
|----------------------------|---------------------------|----------------------------|
| 1 Fabric module top | 5 Fan module 3 status LED | 9 Fan module 7 status LED |
| 2 Fabric module status LED | 6 Fan module 4 status LED | 10 Fan module 8 status LED |
| 3 Fan module 1 status LED | 7 Fan module 5 status LED | |
| 4 Fan module 2 status LED | 8 Fan module 6 status LED | |

For the 7816 switch, the lower fabric module fan modules are numbered 9 through 16.

Note:

- DCS-7816R3-FM and DCS-7808R3-FM look similar. Check the label before populating the chassis.
- For the DCS-7816 switch, the top and bottom fabric modules form one logical fabric module. Both physical modules in a logical pair turn off if either loses power.
- The `show module` command lists the serial number (SN) of only the bottom-slot Fabric Module.

[Fan Status and Fabric Status LEDs on the Rear Panel](#) interpret the state of the fan and fabric status LED.

Table 13: Fan Status and Fabric Status LEDs on the Rear Panel

| LED State | Status |
|-----------|---------------------------------------------|
| Off | Module inserted, but the status is unknown. |
| Green | Module operating normally. |
| Red | Module failed. |

A.4 Power Supply Status Indicators

A.4.1 PWR-D1-3041-AC-BLUE

The power supply status LEDs are on the power supply modules. [Figure A-6: PWR-D1-3041-AC-BLUE Power Supplies](#) displays all the LEDs on the PWR-D1-3041-AC-BLUE AC power supply.

Figure A-6: PWR-D1-3041-AC-BLUE Power Supplies

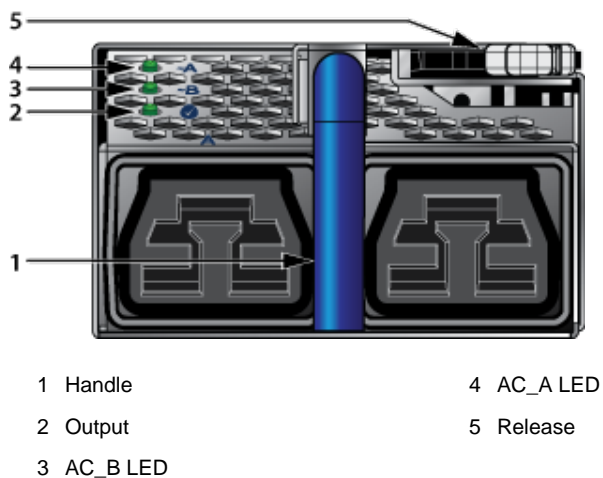

Note: Handle color indicates airflow direction.

[AC Power Supply Status LED States](#) interprets the AC power supply setup for LED status indicators.

Table 14: AC Power Supply Status LED States

| Power Supply Status | LED Name | | |
|---------------------------------|----------|--------|-------------------------------|
| | AC_A | AC_B | Output |
| Normal Operation ⁽¹⁾ | Green | Off | Green |
| No AC Input - Single PSU | Off | Off | Off |
| No AC Input - Parallel PSUs | Yellow | Yellow | Off |
| Standby Mode | Green | Off | Blinking Green ⁽²⁾ |
| AC_A Fail | Yellow | Green | Green |
| AC_B Fail | Green | Yellow | Green |
| Power Supply Fault | Green | Off | Yellow |
| Boot Loader | Off | Off | Blinking ⁽³⁾ |

¹ AC_A is the primary input.

² 1 Hz, 50% Duty Cycle.

³ 1 Hz, 50% Green, 50% Yellow.

A.4.2 PWR-D2-3041-DC-BLUE

The power supply status LEDs are on the power supply modules. [Figure A-7: PWR-D2-3041-DC-BLUE Power Supplies](#) displays all the LEDs on the PWR-D2-3041-DC-BLUE DC power supply.

Figure A-7: PWR-D2-3041-DC-BLUE Power Supplies

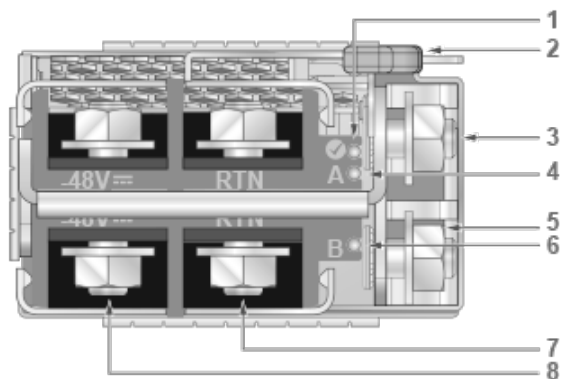

1 Status LED (Output)

2 Release

3 GND terminal

4 Input_A LED

5 Protective earth terminal

6 Input_B LED

7 Battery return terminal

8 -48V terminal



Note: Release lever color indicates airflow direction.

DC Power Supply Status LED States interprets the DC power supply setup for LED status indicators.

Table 15: DC Power Supply Status LED States

| Power Supply Status | LED Name | | |
|-------------------------------------------------|----------|---------|-------------------------------|
| | Input_A | Input_B | Output |
| Normal Operation | Green | Green | Green |
| No DC Input - Single PSU | Off | Off | Off |
| No DC Input - Parallel PSUs (Standby Mode 2) | Yellow | Yellow | Off |
| Standby Mode 1 | Green | Green | Blinking Green ⁽¹⁾ |
| Input_A Fail | Yellow | Green | Green |
| Input_B Fail | Green | Yellow | Green |
| Power Supply Fault | Green | Green | Yellow |
| Boot Loader | Off | Off | Blinking ⁽²⁾ |

¹ 1 Hz, 50% Duty Cycle.

² 1 Hz, 50% Green, 50% Yellow.

³ States can be combined.

Parts List

Each switch has an accessory kit that contains the parts required to install it. The [Table 16: Accessory Kits for the Modular Switches](#) provides further details on each accessory kit.

Table 16: Accessory Kits for the Modular Switches

| | DCS-7804 | DCS-7808 | DCS-7812 | DCS-7816 | DCS-7816L |
|------------------------------------------------------------------------------------------------------------|----------------|----------------|-------------------------|--------------------------|--------------------------|
| Common Cables and Accessories (See Parts Used in All Rack Mount Configurations) | Included | Included | Included | Included | Included |
| Four-post Rack Mount Kit (See Four-Post Rack Mount Parts) | Included | Included | Included | Included | Included |
| Number of Power Cords Included | 12 | 16 | 20 | 24 | 24 |
| Lifting Kit | Not applicable | Not applicable | 4x brackets 8x bolts | 4x brackets 16x bolts | 4x brackets 16x bolts |

Warning:

All provided power cables are for use only with Arista products.

Câbles d'alimentation doivent être utilisés uniquement avec des produits de Arista



警告

すべての電源コードは提供する製品で使用するためだけを目的としている。

電源コードの他の製品での使用の禁止

Aristaが提供するすべての電源コードは、Aristaの製品でのみ使用してください。

The following sections in the chapter list the installation parts provided by the accessory kit in more detail:

- [Parts Used in All Rack Mount Configurations](#)
- [Four-Post Rack Mount Parts](#)

B.1 Parts Used in All Rack Mount Configurations

B.1.1 Cables

Table 17: Cables Provided in Accessory Kit

| Quantity | Description |
|----------|---------------------------------------|
| 2 | RJ-45 Patch Panel Cables, 2 meters. |
| 2 | RJ-45 to DB9 Adapter Cable, 2 meters. |

B.1.2 Getting-Started Booklet

One 2-page document.

B.2 Four-Post Rack Mount Parts

The following sections list the parts provided in the accessory kit for four-post rack mount installations.

Table 18: Four-Post Rack Mount Parts

| Quantity | Description |
|----------|---------------------------------------------------------------------------|
| 1 | Cradle assembly. |
| 12 | Rack mounting screws. |
| 1 | Template for rack mounting (used only for racks requiring mounting nuts.) |

Figure B-1: Four-Post Rack Mount Parts

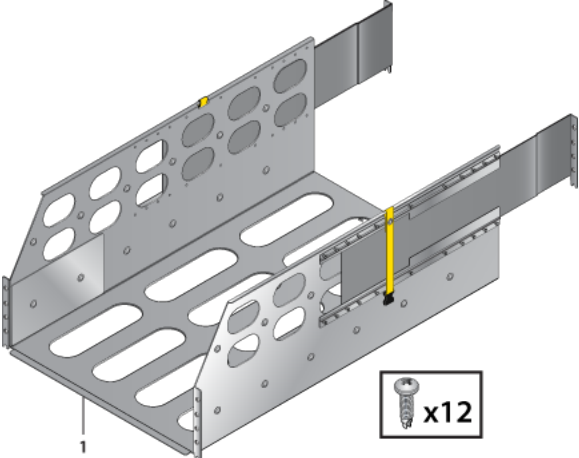
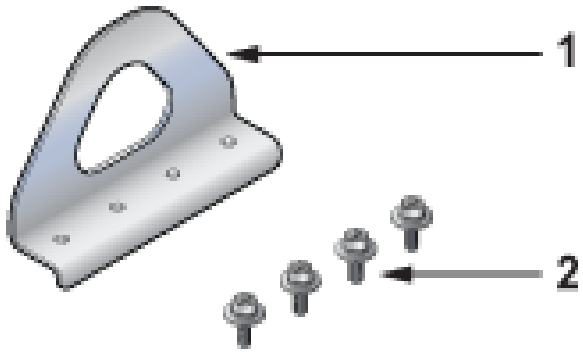

Figure B-2: Lifting Bracket and Bolts (DCS-7812 and DCS-7816 only)



1 Lifting bracket

2 Bolts

Front Panel

This section displays the front panel of all switches this guide covers.



Note: Depending on the components used to populate the chassis, the appearance of a specific switch may differ.



Note: All switches are designed to fit in 19-inch racks.

Figure C-1: DCS-7804 Front Panel (Fully Populated)

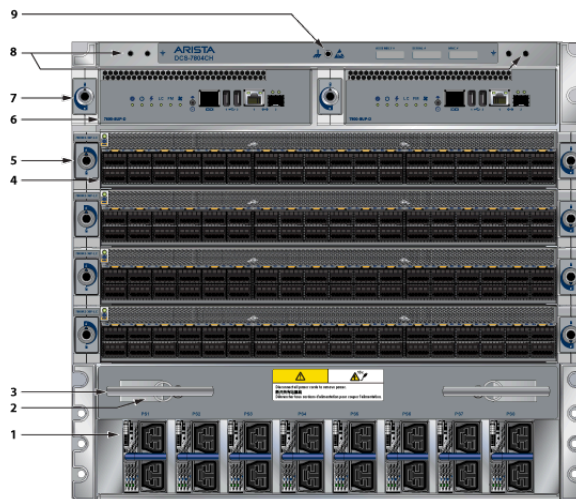

- | | | |
|--------------------------------------------------|----------------------|-----------------------|
| 1 Power supplies | 4 Linecard | 7 Supervisor lock |
| 2 Linecard and Supervisor extraction tool tether | 5 Linecard lock | 8 Grounding locations |
| 3 Extraction tool | 6 Supervisor modules | 9 ESD attach point |

Figure C-2: DCS-7808 Front Panel (Fully Populated)

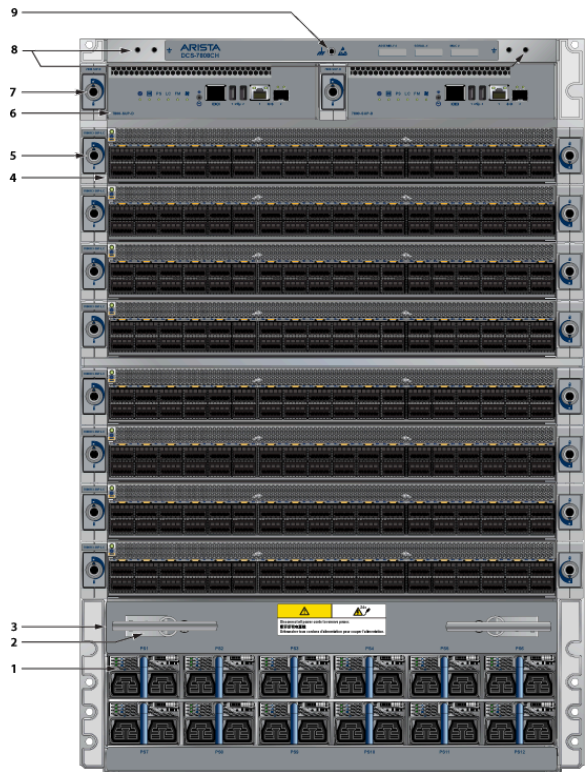

- | | | |
|--------------------------------------------------|----------------------|-----------------------|
| 1 Power supplies | 4 Linecards | 7 Supervisor lock |
| 2 Linecard and Supervisor extraction tool tether | 5 Linecard lock | 8 Grounding locations |
| 3 Extraction tool | 6 Supervisor modules | 9 ESD attach point |

Figure C-3: DCS-7812 Front Panel (Fully Populated)

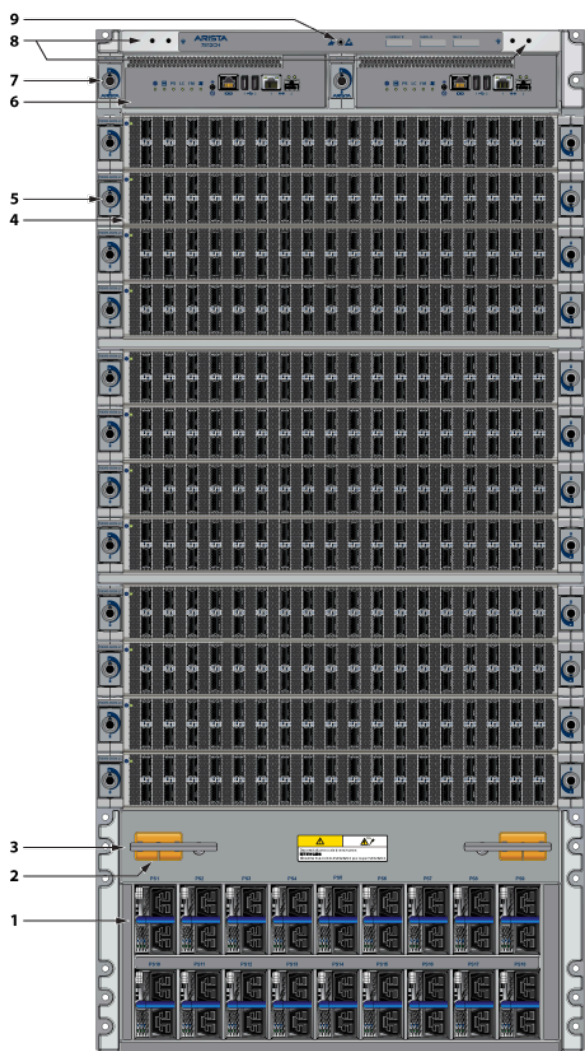

- | | | |
|--------------------------------------------------|----------------------|-----------------------|
| 1 Power supplies | 4 Linecard | 7 Supervisor lock |
| 2 Linecard and Supervisor extraction tool tether | 5 Linecard lock | 8 Grounding locations |
| 3 Extraction tool | 6 Supervisor modules | 9 ESD attach point |

Figure C-4: DCS-7816 Front Panel (Fully Populated)

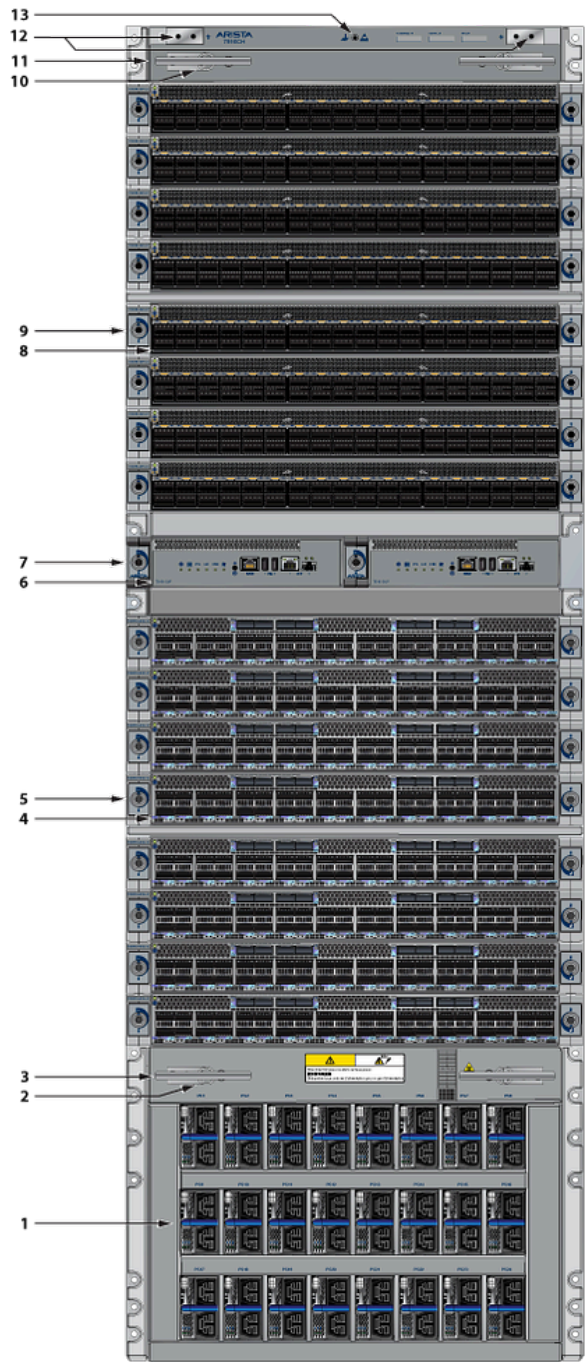

- | | | |
|--------------------------------------------------|---------------------------------------------------|------------------------|
| 1 Power supplies | 6 Supervisor modules | 11 Extraction tool |
| 2 Linecard and Supervisor extraction tool tether | 7 Supervisor lock | 12 Grounding locations |
| 3 Extraction tool | 8 Linecard | 13 ESD attach point |
| 4 Linecard | 9 Linecard lock | |
| 5 Linecard lock | 10 Linecard and Supervisor extraction tool tether | |

Figure C-5: DCS-7816L Front Panel (Fully Populated)

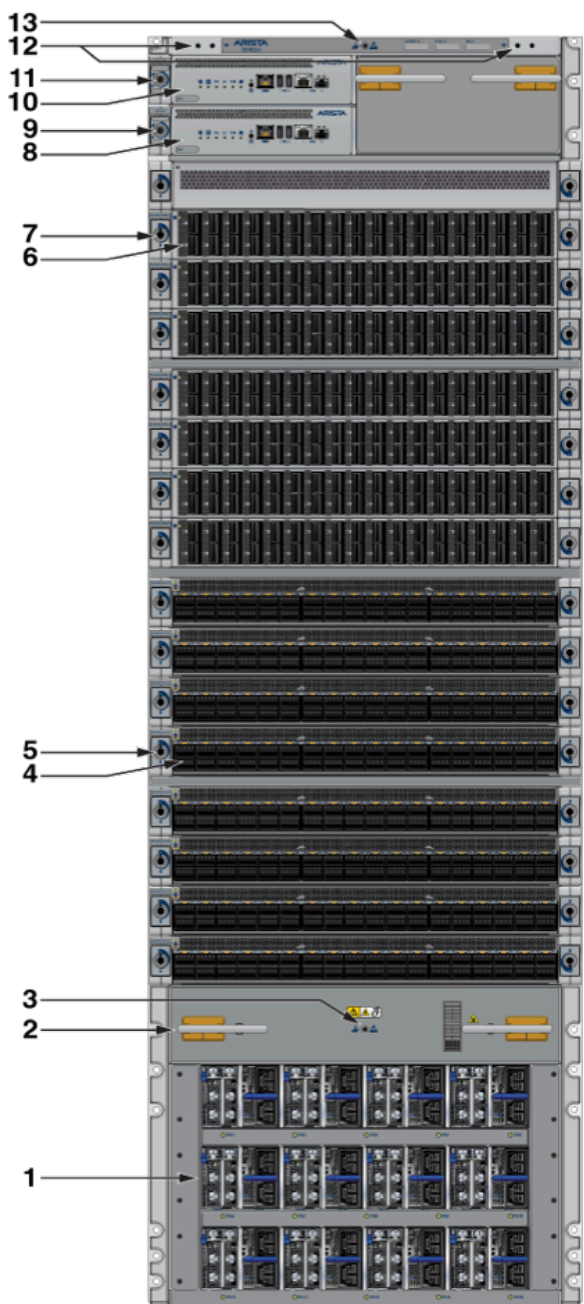

- | | | |
|--------------------------------------------------|----------------------|------------------------|
| 1 Power supplies | 6 Linecard | 11 Supervisor lock |
| 2 Linecard and Supervisor extraction tool tether | 7 Linecard lock | 12 Grounding locations |
| 3 Extraction tool | 8 Supervisor module | 13 ESD attach point |
| 4 Linecard | 9 Supervisor lock | |
| 5 Linecard lock | 10 Supervisor module | |

Rear Panel

This section displays the rear panel of all switches this guide covers.



Note: Depending on the components used to populate the chassis, the appearance of a specific switch could be different.

Figure D-1: DCS-7804 Rear Panel (Fully Populated)

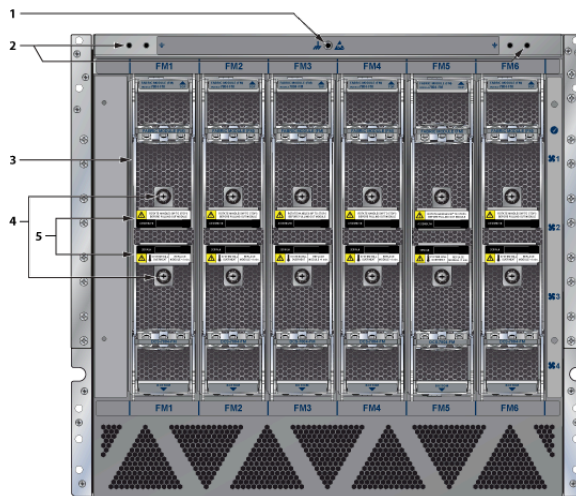

1 ESD attachment point

3 Fabric modules

5 Fabric module ejector lever

2 Chassis ground

4 Fabric module screw

Figure D-2: DCS-7808 Rear Panel (Fully Populated)

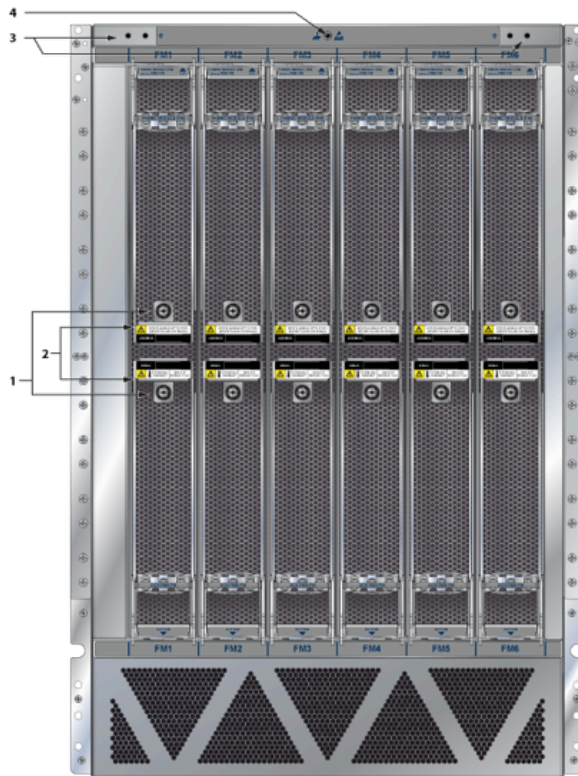

- 1 Fabric module screw
- 2 Fabric module ejector lever
- 3 Chassis ground
- 4 ESD attachment point

Figure D-3: DCS-7812 Rear Panel (Fully Populated)

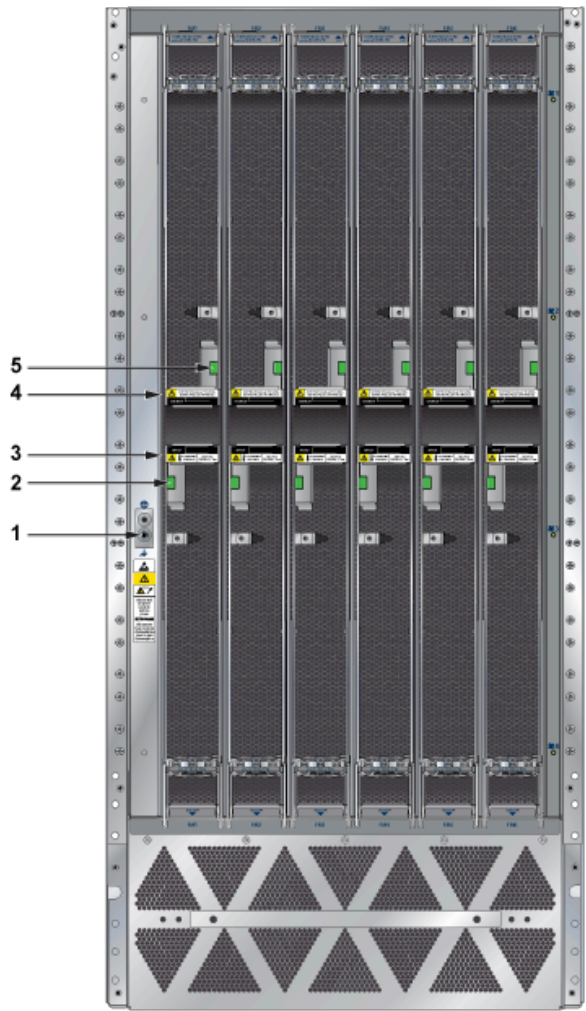

1 ESD attachment point

2 Fabric module release button

3 Fabric module ejector lever

4 Fabric module ejector lever

5 Fabric module release button

Figure D-4: DCS-7816 Rear Panel (Fully Populated)

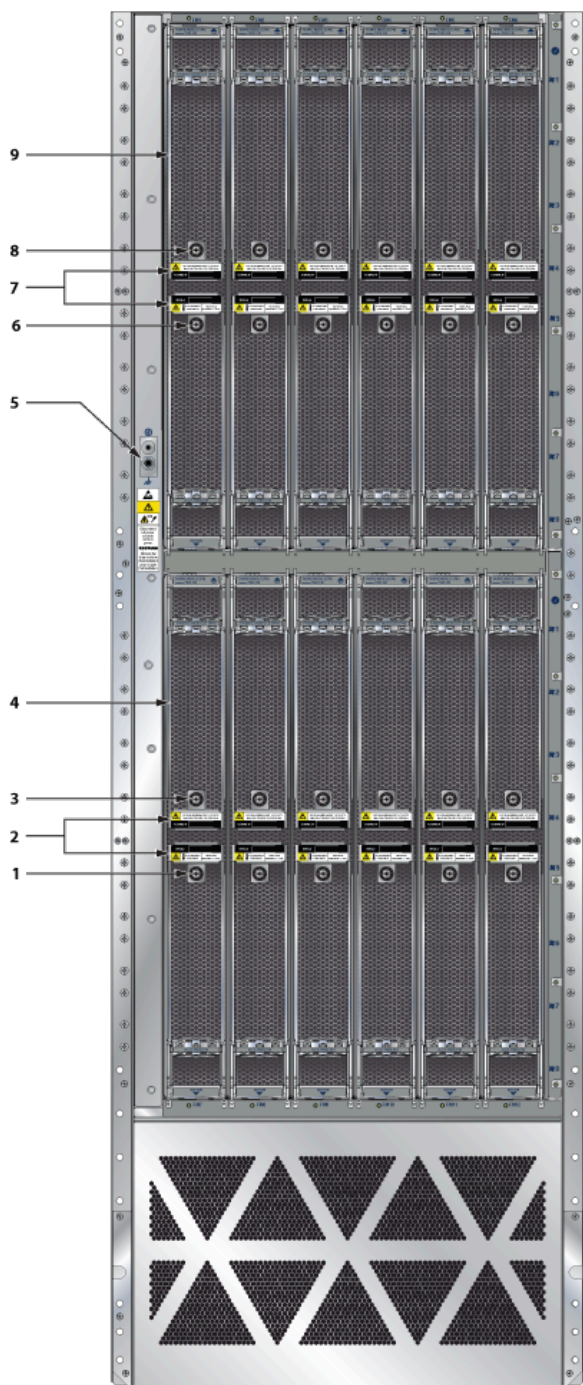

1 Fabric module screw

2 Fabric module ejector lever

3 Fabric module screw

4 Fabric module

5 ESD attachment point

6 Fabric module screw

7 Fabric module ejector lever

8 Fabric module screw

9 Fabric module

Figure D-5: DCS-7816L Rear Panel (Fully Populated)

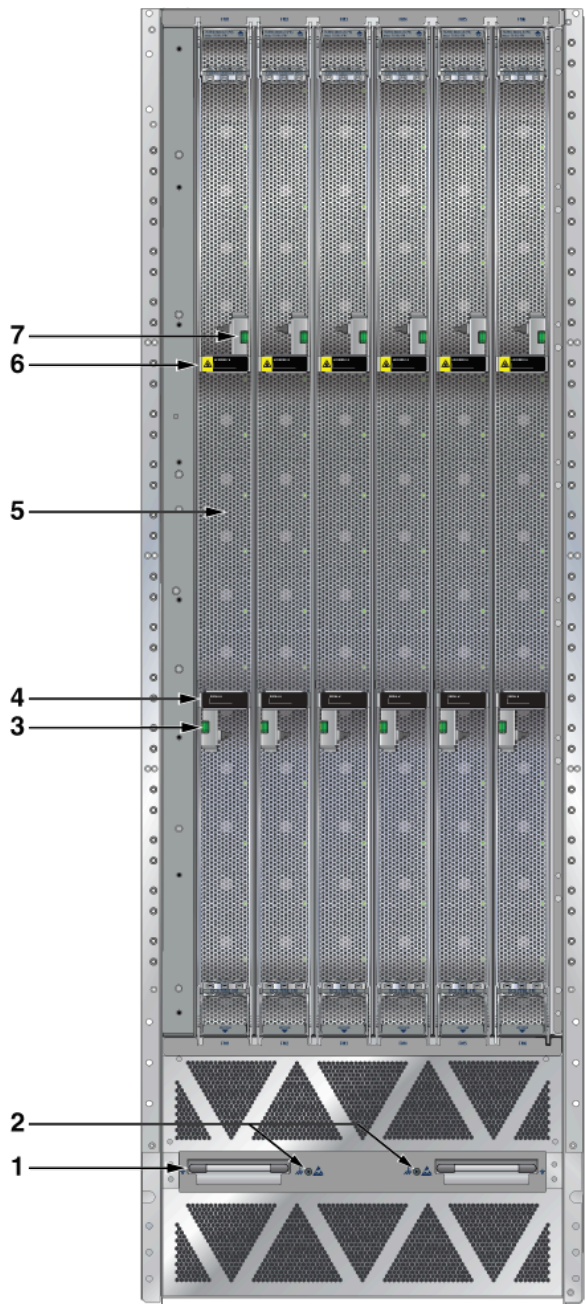

1 Cover release

2 ESD attachment point

3 Fabric module release button

4 Fabric module ejector lever

5 Fabric module

6 Fabric module ejector lever

7 Fabric module release button

Linecards

This section displays the linecards supported by modular switches this guide covers.

Figure E-1: DCS-7800R3-48CQ, DCS-7800R3K-48CQ, DCS-7800R3-48CQM, DCS-7800R3-48CQ2, DCS-7800R3-48CQMS, and DCS-7800R3-48CQM2



Figure E-2: DCS-7800R3-36P

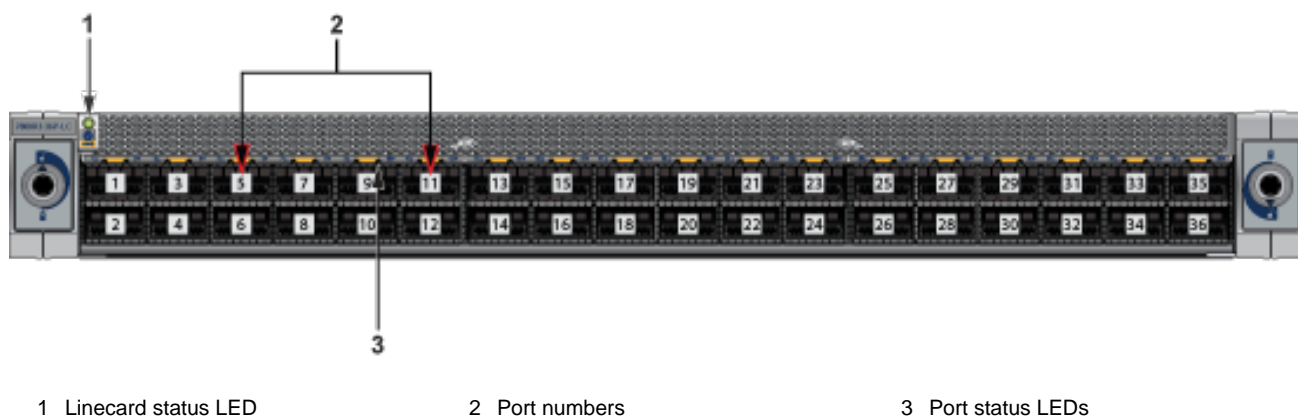

Figure E-3: DCS-7800R3-36D and DCS-7800R3K-36DM



1 Linecard status LED

2 Port numbers

3 Port status LEDs

Figure E-4: DCS-7800R3K-72Y-LC

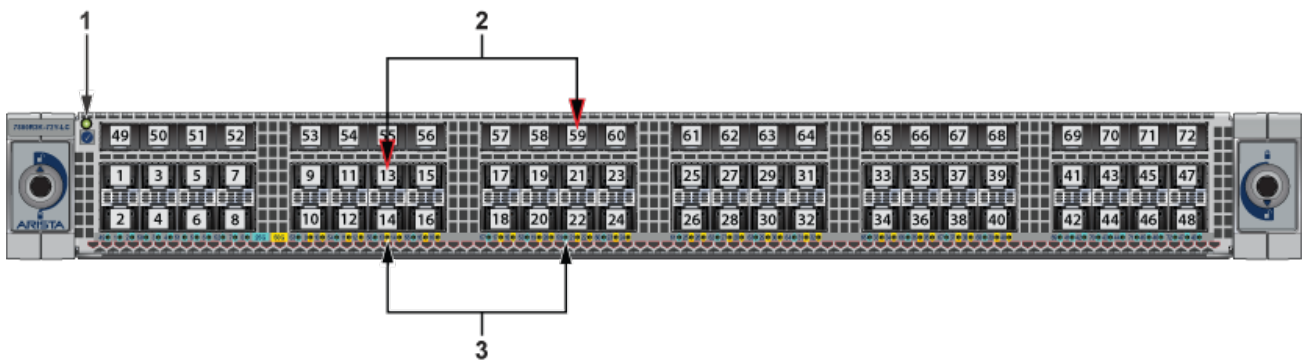

1 Linecard status LED

2 Port numbers

3 Port status LEDs

Maintenance and Field Replacement

This section discusses the process for replacing switch components.

- [Linecard and Supervisor Extraction Tools](#)
- [Power Supplies](#)
- [Fabric and Fan Module \(Fabric Module\)](#)
- [Fan Module \(within Fabric Module\)](#)
- [Supervisor Module](#)
- [Linecards](#)

You must ensure that at least one of the secondary grounding pads on the chassis's front panel is connected to the data center ground. While working on the switches, use grounded, anti-static wrist straps connected to one of the attach points on the switch to ground yourself and prevent ESD damage to the switch.



Note: Illustrations in this section are examples of a representative switch and component(s). Apply procedures to component(s) supported by the specific switch. You must use component(s) and the appropriate slots for those component(s) when replacing or adding them.

Inspect the connectors for damage before installing components into the chassis.

F.1 Linecard and Supervisor Extraction Tools

Assemble and tether the extraction tools to remove and insert linecards and supervisor modules into the chassis.



Note: The [Front Panel](#) shows the locations for tethering and storing the extraction tools.

F.1.1 Assembling and Storing the Extraction Tools

The extraction tools come with a lanyard and tethering plug, as shown in [Figure F-1: Linecard and Supervisor Module Extraction Tool and Tether Assembly](#).

Figure F-1: Linecard and Supervisor Module Extraction Tool and Tether Assembly

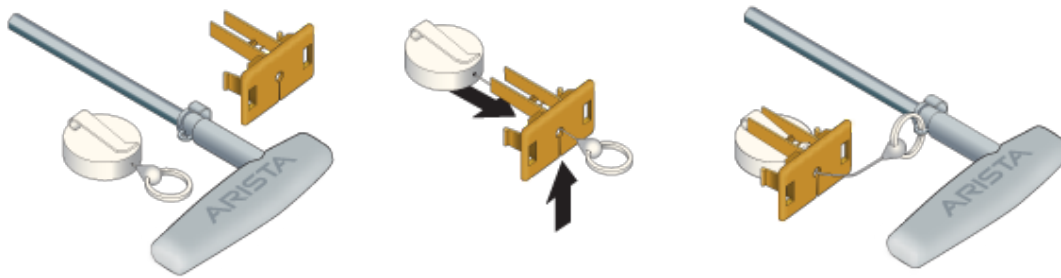

Use the following steps to attach the tethering mechanism to the extraction tool.

1. Extend and slip the lanyard thread through the slot in the plastic tether.
2. Attach the ring to the extraction tool.
3. Plug the plastic tether into one of the slots ([Figure C-1: DCS-7804 Front Panel \(Fully Populated\)](#)).
4. Repeat for the other tools as appropriate.

F.2 Power Supplies

The switches support AC or DC Power supplies. Depending on the switch model, they ship with a number of populated slots. Empty slots are covered with a blank. To add a new power supply in one of the available slots, remove the blank covering the slot before inserting a new power supply. When adding or replacing power supplies, perform the following steps for ESD protection.



Note: The [front panel](#) shows the power supply locations for your device.

1. Connect at least one of the chassis grounding pads located on the front and rear panels of the chassis to the data center ground as needed to ensure that the switch is grounded.
2. Put on an anti-static ESD wrist strap and connect it to one of the attach points on the switch.
3. To add the new power supply, remove the power supply to be replaced ([Removing AC Power Supply](#), [Removing DC Power Supply](#)) or the blank for the slot ([Removing Power Supply Blank](#)).

F.2.1 Removing AC Power Supply

Perform the following steps to remove an AC power supply.

1. Put on a grounded, anti-static ESD strap.

2. Unplug the cable(s) by squeezing the cable release. Up to two cables could be powering each PSU.
3. Squeeze the latch release.
4. Remove the power supply from the switch using the power supply latch release and handle.

F.2.2 Installing AC Power Supply

You must make space for installing the power supply by removing an existing one ([Removing AC Power Supply](#), [Removing DC Power Supply](#)) or removing a blank ([Removing Power Supply Blank](#)) from a power supply slot available on the switch.

Perform the following steps to install an AC power supply:

1. Put on a grounded, anti-static ESD strap.
2. Unpack the new power supply.
3. Insert the new power supply into the empty power supply slot.
4. After you insert the power supply, push gently on the power supply until the power supply is fully seated.
5. Connect the power cord(s) to the power supply. Up to two cables can power each PSU.
6. Connect to the power source.
7. Verify normal operation using the LED indicators for your switch [Table 14: AC Power Supply Status LED States](#).

F.2.3 Removing DC Power Supply

- Remove power from DC circuits by turning off the power line servicing the circuits.
- Make sure to remove the ground connection *last* when removing power.

1. Put on a grounded, anti-static ESD strap.
2. Disconnect the power cable from the DC power source.
3. Squeeze the latch release.
4. Remove the power supply from the switch using the power supply latch release and handle.
5. Remove each power cable lug to the terminal studs with the flange locking nuts.
6. Remove the flange locking nuts to each of the terminal studs.
7. Disconnect the power cable lug from the terminal studs.

F.2.4 Installing DC Power Supply

You must make space for installing the power supply by removing an existing one ([Removing AC Power Supply](#), [Removing DC Power Supply](#)) or removing a blank ([Removing Power Supply Blank](#)) from a power supply slot available on the switch.

Perform the following steps to install a DC power supply.

1. Put on a grounded ESD strap.
2. Unpack the new power supply.
3. Connect the cables for your power supply as explained in the guide ([Cabling the Modular Switch](#)).

-
4. Insert the new power supply into the empty power supply slot.
 5. After you insert the power supply, push gently on the power supply until the power supply is fully seated.
 6. Connect to the power source.
 7. Verify normal operation using the LED indicators for your switch [Table 15: DC Power Supply Status LED States](#).

F.2.5 Removing Power Supply Blank

Friction holds The power supply blank in place.

1. Put on a grounded, anti-static ESD strap.
2. Remove the blank from the power supply slot you are going to populate.



Note: You can save the blank for future use as needed. A blank is needed for the switch to operate normally in an unpopulated power supply slot.

F.3 Fabric and Fan Module (Fabric Module)

The fabric and fan modules are hot-swappable and accessible from the switch's rear panel ([Rear Panel](#)). You must consider that the module you are inserting is compatible with the switch and the module you are replacing. Perform the following steps to remove and replace a fabric and fan module or a fan-only module if your switch supports one.



Note: The DCS-7816 switch has twelve fabric modules, each half-height.

F.3.1 Removing Fabric Module

1. Put on a grounded, anti-static ESD strap.
2. Loosen the two Phillips screws on the fabric module.



Note: The DCS-7812R3-FM fabric module has green latch release buttons. Use these instead.

3. Pull out the ejector levers on the fabric module.

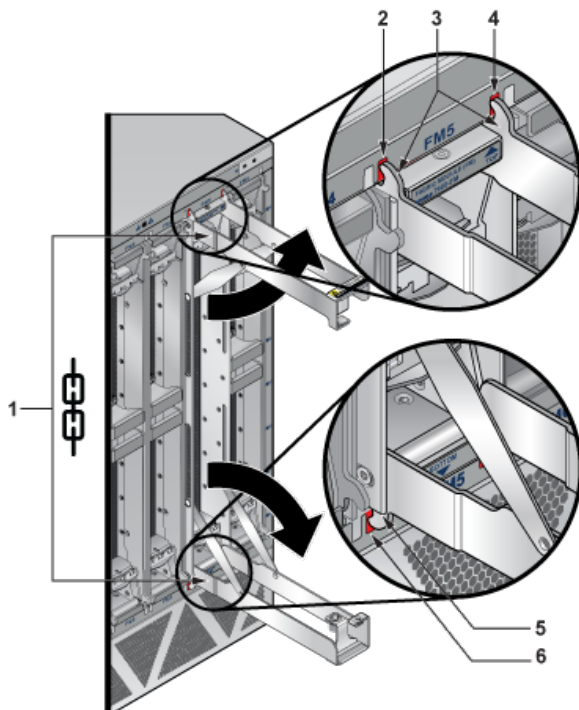

1 Fabric module ejector levers

2 Claw position on chassis

3 Fabric module ejector claws

4 Claw position on chassis

5 Fabric module ejector claw

6 Claw position on chassis

4. Pull the ejector handles outwards by 90 degrees to disengage the fabric module.
5. Pull on the ejector handles to remove the fabric module from the slot.



Note: Fabric modules can be heavier than 25 lbs. Provide adequate support while handling them to prevent injury or damage.

F.3.2 Installing Fabric Module

You must make space for installing the module by removing an existing one ([Removing Fabric Module](#)) from a fabric module slot available on the switch.

Perform the following steps to install the module:

1. Put on a grounded, anti-static ESD strap.
2. Unpack the module to be installed.
3. Slide the module into the open slot until the injector claw touches the chassis's rear face.

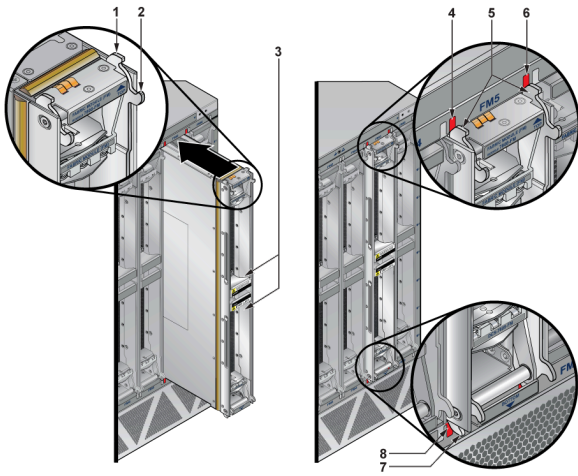

- | | | |
|-----------------------------------------|------------------------------------|-------------------------------------------|
| 1 Fabric module top right injector claw | 4 Claw position on chassis | 7 Fabric module bottom left injector claw |
| 2 Fabric module top right ejector claw | 5 Fabric module top injector claws | 8 Claw position on chassis |
| 3 Fabric module ejector levers | 6 Claw position on chassis | |

4. Fully open the ejector levers at 90 degrees and seat the module.



Note: The ejector claws should be touching the rear face of the chassis.

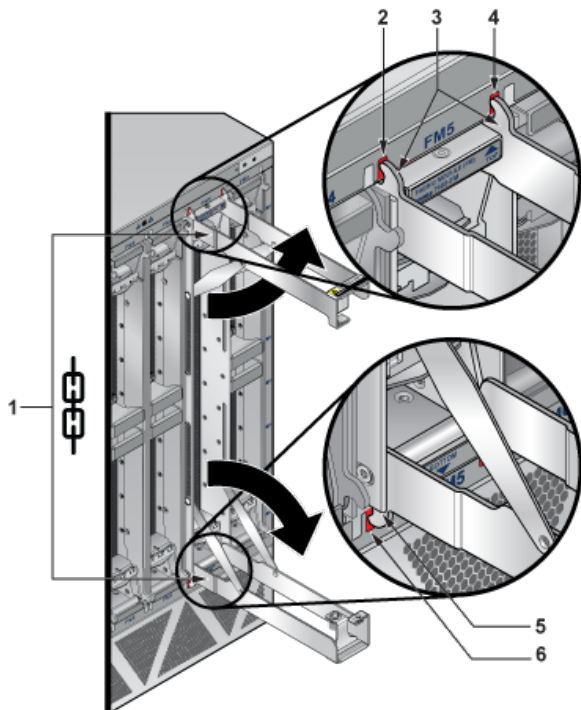

- | | | |
|--------------------------------|-------------------------------|------------------------------|
| 1 Fabric module ejector levers | 3 Fabric module seating claws | 5 Fabric module seating claw |
| 2 Claw position on chassis | 4 Claw position on chassis | 6 Claw position on chassis |

5. Close the ejector levers in unison.

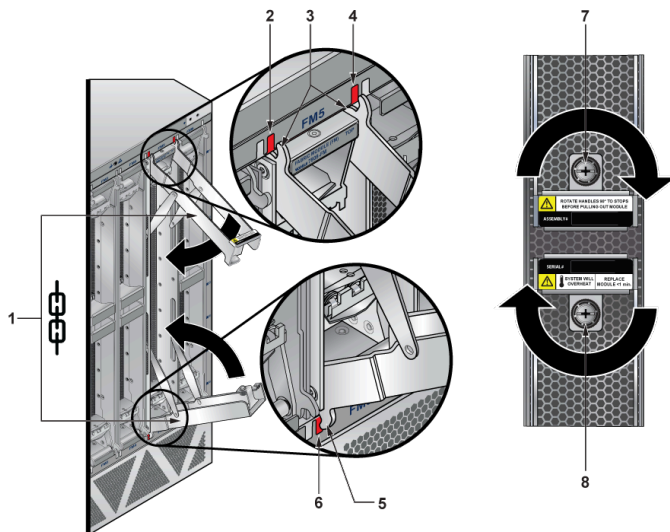

- | | | |
|--------------------------------|------------------------------|---------|
| 1 Fabric module ejector levers | 4 Claw position on chassis | 7 Screw |
| 2 Claw position on chassis | 5 Fabric module ejector claw | 8 Screw |
| 3 Fabric module ejector claws | 6 Claw position on chassis | |



CAUTION: Ensure that the claws engage correctly on the chassis.

6. Screw in the two Phillips screws using a PH3 driver on a battery-operated screwdriver with torque set between 16 and 18 in-lbs.



Note: The DCS-7812 does not require screws. The green latch release buttons will pop out when the fabric module is seated.

7. Verify that the module is operates normally ([Table 13: Fan Status and Fabric Status LEDs on the Rear Panel](#)).
8. Use the `show environment cooling` command to verify normal operation further.

F.4 Fan Module (within Fabric Module)

The fabric and fan modules are hot-swappable and accessible from the switch's rear panel ([Rear Panel](#)). You must ensure that the module you insert is compatible with the switch and the module you are replacing. Perform the following steps to remove and replace a fan module that is part of the fabric module.

1. Remove the fabric module with the fan to be replaced ([Removing Fabric Module](#)).
2. Place the fabric module on a flat work surface. A cart or table designated for such tasks is typically appropriate.
3. Locate the failed fan and
 - a. Push the green latch, then
 - b. Rotate the fan lever to the open position.



Note: See figure below.

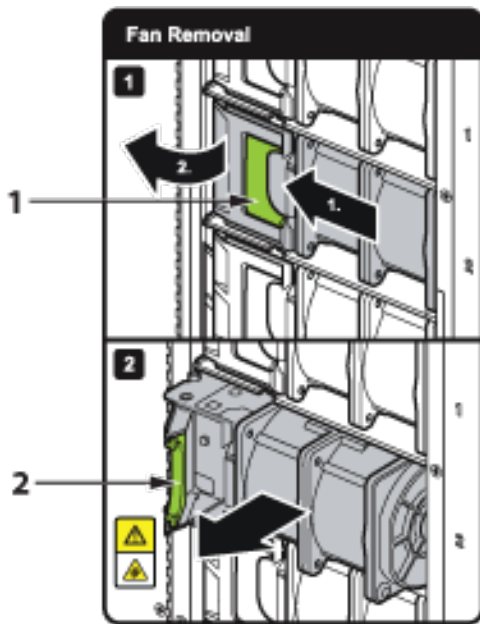

- 1 Release latch
- 2 Fan lever

4. Lift the fan straight up and out of the fabric module.
5. Insert the replacement fan straight down and into the fabric module.
6. Rotate the fan lever to the closed position.
7. Ensure that the green latch has securely slid into the latched and locked position.
8. Reinstall the fabric module into the chassis ([Installing Fabric Module](#)).



Note: The DCS-7816 switch has twelve fabric modules, each half-height, and currently does not have a label depicting fan removal.

F.5 Supervisor Module

The supervisor modules are hot-swappable and accessible from the front of the switch. You must consider that the module you are inserting is compatible with the switch and the module you are replacing. Use the following procedure to remove and replace a supervisor module. For the supervisor module locations for your device, refer to the [Front Panel](#).

F.5.1 Removing Supervisor Module

Perform the following steps to remove the module.

1. Put on a grounded ESD strap.
2. Use the extraction tool supplied ([Front Panel](#)) to unlock the supervisor card.
3. Pull the supervisor module out.
4. Slide the supervisor module out of the slot.

F.5.2 Installing Supervisor Module

You must make space for installing the module by removing an existing one ([Removing Supervisor Module](#)) or a blank ([Removing Supervisor Module Blank](#)) from a supervisor module slot available on the switch.

Perform the following steps to install the module:

1. Put on a grounded, anti-static ESD strap.
2. Unpack the supervisor module to be installed.
3. Slide the supervisor module into the slot.
4. Lock the supervisor module using the tool supplied ([Front Panel](#)).
5. Verify that the module is operating normally ([Table 10: Supervisor Status LED States](#)).

F.5.3 Removing Supervisor Module Blank

The supervisor module blank has plastic latches.

1. Put on a grounded, anti-static ESD strap.
2. Grip the plastic handles to release the latch and remove the blank from the supervisor module slot you are going to populate.

You can save the blank for future use as needed. A blank is needed for the switch to operate normally in an unpopulated supervisor module slot.

F.6 Linecards

The linecards are hot-swappable and accessible from the front of the switch. You must consider that the linecard you are inserting is compatible with the switch and the linecard you are replacing. Use the following procedure to remove and replace a linecard. If you are adding a new linecard, remove the blank from the linecard slot and install the new linecard. For the linecard locations on your switch, refer to the [Front Panel](#).

F.6.1 Removing Linecard

Perform the following steps to remove a linecard:

1. Put on a grounded, anti-static ESD strap.
2. Use the tools supplied ([Front Panel](#)) simultaneously on each end of the linecard.
3. Pull the linecard out gently after being released.
4. Slide linecard out of the slot.

F.6.2 Installing Linecard

You must make space for installing the linecard by removing an existing one ([Removing Linecard](#)) or a blank ([Removing Linecard Blank](#)) from a linecard slot available on the switch.

1. Put on a grounded, anti-static ESD strap.
2. Unpack the linecard to be installed.
3. Slide the linecard into the slot.
4. Use the tools supplied ([Front Panel](#)) simultaneously on each end of the linecard to lock it in place.
5. Verify that the linecard is operates normally ([Linecard Module Indicators](#)).

F.6.3 Removing Linecard Blank

Perform the following steps to remove linecard blank:

1. Put on a grounded, anti-static ESD strap.
2. Grip the plastic handles to release the latch and remove the blank from the linecard slot you will populate.

The linecard blank has plastic latches. You can save the blank for future use as needed. The blank is needed for the switch to operate normally for an unpopulated linecard slot.

Regulatory Model Numbers

This section lists the Regulatory Model Numbers (RMNs), where applicable, for the product models for the switches described in this document.

Table 19: Regulatory Model Numbers and Product Numbers

| Regulatory Model Number (RMN) | Product Number(s) |
|-------------------------------|-------------------|
| 7804 | 7804 |
| 7808 | 7808 |
| 7812 | 7812 |
| 7816 | 7816 |
| 7816L | 7816L |

Taiwan RoHS Information

This section provides the Taiwan RoHS information for switches covered by this guide.

台灣RoHS相關資訊請參考下列網址: <https://www.arista.com/assets/data/pdf/AristaBSMIroHS.pdf>.