

ARISTA

Quick Start Guide

Arista NDR Appliances

DCA-NDR-S100MB
DCA-NDR-S10
DCA-NDR-NB10

DCA-NDR-S1
DCA-NDR-S40
DCA-NDR-CC

DCA-NDR-S5
DCA-NDR-STR
DCA-NDR-A5



Headquarters	Support	Sales
5453 Great America Parkway Santa Clara, CA 95054 USA +1-408-547-5500	+1-408-547-5502 +1-866-476-0000	+1-408-547-5501 +1-866-497-0000
www.arista.com/en/	support@arista.com	sales@arista.com

© Copyright 2026 Arista Networks, Inc. All rights reserved. The information contained herein is subject to change without notice. The trademarks, logos, and service marks ("Marks") displayed in this documentation are the property of Arista Networks in the United States and other countries. Use of the Marks is subject to the Arista Networks Terms of Use Policy, available at www.arista.com/en/terms-of-use. Use of marks belonging to other parties is for informational purposes only.

Contents

- Chapter 1: Overview.....1**
 - 1.1 Scope..... 1
 - 1.2 Receiving and Inspecting the Equipment..... 1
 - 1.3 Installation Process..... 2
 - 1.4 Safety Information..... 3
 - 1.5 Obtaining Technical Assistance..... 3
 - 1.6 Specifications..... 3

- Chapter 2: Preparation.....5**
 - 2.1 Site Selection..... 5
 - 2.2 Tools and Parts Required for Installation..... 6
 - 2.3 Electrostatic Discharge (ESD) Precautions..... 6

- Chapter 3: Rack Mounting an Arista NDR Appliance.....7**
 - 3.1 Installing 1RU Arista NDR appliances..... 7
 - 3.2 Installing 2RU Arista NDR Appliances..... 9
 - 3.3 Installing S40 1RU Arista NDR Appliances..... 13
 - 3.3.1 Installing the S40 Arista NDR Appliance Bezel..... 14
 - 3.3.2 Installing the Cable Management Arms..... 14
 - 3.4 Installing STR 4RU Arista NDR Appliances..... 15
 - 3.4.1 Installing STR Arista NDR Appliances Hard Disk Drives..... 18

- Chapter 4: Cabling the Appliance..... 20**

- Chapter 5: Configuring the Arista NDR Platform.....21**
 - 5.1 Connecting to the Admin CLI..... 21
 - 5.2 Configuring the Appliance..... 21
 - 5.2.1 Configuring the Management Interface..... 22
 - 5.2.2 Configuring DNS..... 22
 - 5.2.3 Configuring NTP..... 22
 - 5.2.4 Configuring Proxy..... 23
 - 5.2.5 Configuring IPMI Ethernet Interface..... 23
 - 5.3 Verifying the Configuration..... 24

- Appendix A: Status Indicators.....25**
 - A.1 Control Panel Indicators..... 25
 - A.2 Front Panel Status Indicators..... 26
 - A.3 Rear Panel Status Indicators..... 28

- Appendix B: Parts List..... 33**
 - B.1 Rack Mount Parts..... 33
 - B.2 Cables..... 33

Appendix C: Front Panel.....	35
Appendix D: Rear Panel.....	37
Appendix E: Regulatory Model Numbers.....	40

Overview

The Arista Network Detection and Response (NDR), previously known as Awake Security, operates on a physical appliance or a combination of physical and virtual appliances. The hardware can be purchased using a Stock Keeping Unit (SKU) with the Data Center Automation (DCA) prefix, formatted as DCA-NDR-XY. In this format, "X" represents the type of appliance: A (All-in-One), NB (Nucleus), CC (Central Console), or S (Sensor). The letter "Y" indicates the maximum Gb/s rate, which currently can be 100MB, 1GB, 5GB, 10GB, or 40GB.

Each type of appliance has unique characteristics, so identify the correct appliance (All-in-one, Nucleus, Central Console, Storage, or Sensor) for its function before starting the installation tasks.

The Overview section discusses the following topics:

- [Scope](#)
- [Receiving and Inspecting the Equipment](#)
- [Installation Process](#)
- [Safety Information](#)
- [Obtaining Technical Assistance](#)
- [Specifications](#)

1.1 Scope

This guide is intended for trained service personnel and technicians who need to install and configure Arista NDR appliances with the specified SKU format:

- DCA-NDR-S100MB, 1RU Sensor Appliance
- DCA-NDR-S1, 1RU Sensor Appliance
- DCA-NDR-S5, 2RU Sensor Appliance
- DCA-NDR-S10, 2RU Sensor Appliance
- DCA-NDR-S40, 1RU Sensor Appliance
- DCA-NDR-STR, 4RU Storage Appliance (Optional with DCA-NDR-S40)
- DCA-NDR-NB10, 2RU Nucleus Appliance
- DCA-NDR-CC, 2RU Central Console Appliance
- DCA-NDR-A5, 2RU All-in-One Appliance

Warning:



Only qualified personnel should install, service, or replace this equipment.

Seul le personnel qualifié doit installer, service, ou remplacer cet équipement.

1.2 Receiving and Inspecting the Equipment

When you receive the Arista NDR appliance(s), inspect the shipping boxes for any external damage. If you believe any part of the shipment is damaged, keep the packing materials, as the carrier may need to inspect them.

If the boxes arrived undamaged, unpack them with care. Do not discard any accessories that may have been included with the main unit.

Review the packing list and verify that you received all items listed. Cross-check the packing list with your purchase order. [Appendix B](#) contains a list of components included with the Arista NDR appliance.

1.3 Installation Process

The following tasks are required to install and use the Arista NDR appliance:

1. Select and prepare the installation site ([Site Selection](#)).
2. Assemble the installation tools ([Tools and Parts Required for Installation](#)).
3. Attach the mounting brackets and install the Arista NDR appliance in an equipment rack ([Rack Mounting an Arista NDR Appliance](#)).
4. Connect the Arista NDR appliance to the power source and network devices ([Cabling the Appliance](#)).
5. Configure the Arista NDR appliance ([Configuring the Appliance](#)).

Warning:

Class 1 Laser Product: This product has provisions to install Class 1 laser transceivers which provide optical coupling to the communication network. Once a Class 1 laser product is installed, the equipment is a Class 1 Laser Product (Appareil à Laser de Classe 1). The customer is responsible for selecting and installing the Class 1 laser transceiver and for insuring that the Class 1 AEL (Allowable Emission Limit) per EN/IEC 60825, CSA E60825-1, and Code of Federal Regulations 21 CFR 1040 is not exceeded after the laser transceiver have been installed. Do not install laser products whose class rating is greater than 1. Refer to all safety instructions that accompanied the transceiver prior to installation. Only Class 1 laser devices, certified for use in the country of installation by the cognizant agency are to be utilized in this product.



Produit Laser de classe 1: Ce produit a des dispositions pour installer des émetteurs-récepteurs de laser de classe 1 qui offre de couplage au réseau de communication optique. Une fois un produit laser de classe 1 est installé, l'équipement est un produit Laser de classe 1 (Appareil à Laser de Classe 1). Le client est responsable pour sélectionner et installer l'émetteur/récepteur de laser de classe 1 et pour assurer que la classe 1 AEL (limite d'émission admissible) par EN/IEC 6-825, CSA E60825-1, et Code des règlements fédéraux 21 CFR 1040 ne soit pas dépassée après avoir installé l'émetteur/récepteur de laser. Ne pas installer des appareils à laser dont la cote de classe est supérieure à 1. Voir toutes les consignes de sécurité qui ont accompagné l'émetteur-récepteur avant l'installation. Seuls appareils laser de classe 1 certifiés pour une utilisation dans le pays d'installation par l'organisme compétent doivent être utilisées dans ce produit. Ultimate disposal of this product should be in accordance with all applicable laws and regulations.

Warning:

Ultimate disposal of this product should be handled in accordance with all national laws and regulations.



Aucune pièce réparable par l'utilisateur à l'intérieur. Confiez toute réparation à un technicien qualifié.

1.4 Safety Information

Refer to the Arista Networks *Compliance and Safety Guides* document, translated into several languages and available at the bottom of the page of the **Hardware** tab at <https://www.arista.com/en/support/product-documentation>.

1.5 Obtaining Technical Assistance

Any customer, partner, reseller, or distributor holding a valid Arista Service Contract can obtain technical support in any of the following ways:

- **Email:** support@arista.com.

This is the easiest way to create a new service request. Include a detailed description of the problem.

- **Web:** <https://www.arista.com/en/support>

You can create a support case through the support portal on our website. You can also download the most current software and documentation, as well as view FAQs, Knowledge Base articles, Security Advisories, and Field Notices.

- **Phone:** +1 866-476-0000 or +1 408-547-5502.

Warning:



No user-serviceable parts inside. Refer all servicing to qualified service personnel.

Aucune pièce réparable par l'utilisateur à l'intérieur. Confiez toute réparation à un technicien qualifié.

1.6 Specifications

Table 1: Arista NDR appliance Specifications (RUs, Dimensions, and Weight)

Arista NDR appliance SKU	Rack Units (RUs)	Dimensions (W x H x D)	Weight
DCA-NDR-S100MB	1	43.7 x 4.3 x 65.0 cm (17.2 x 1.7 x 25.6 in)	20.87 kg (46 lbs)
DCA-NDR-S1	1	43.7 x 4.3 x 65.0 cm (17.2 x 1.7 x 25.6 in)	20.87 kg (46 lbs)
DCA-NDR-S5	2	43.7 x 89.0 x 72.3 cm (17.2 x 3.5 x 28.5 in)	32.7 kg (72.0 lbs)
DCA-NDR-S10	2	43.7 x 89.0 x 72.3 cm (17.2 x 3.5 x 28.5 in)	32.7 kg (72.0 lbs)
DCA-NDR-S40	1	43.4 x 4.2 x 35.8 cm (17.08 x 1.6 x 14 in)	15.8 kg (34.83 lbs)
DCA-NDR-STR	4	42.3 x 17.43 x 87.5 cm (16.65 x 6.86 x 34.45 in)	29.20 kg (64.37 lbs)
DCA-NDR-NB10	2	43.7 x 89.0 x 72.3 cm (17.2 x 3.5 x 28.5 in)	32.7 kg (72.0 lbs)
DCA-NDR-CC	2	43.7 x 89.0 x 72.3 cm (17.2 x 3.5 x 28.5 in)	32.7 kg (72.0 lbs)
DCA-NDR-A5	2	43.7 x 89.0 x 72.3 cm (17.2 x 3.5 x 28.5 in)	32.7 kg (72.0 lbs)

Preparation

The Preparation section discusses the following topics:

- [Site Selection](#)
- [Tools and Parts Required for Installation](#)
- [Electrostatic Discharge \(ESD\) Precautions](#)

2.1 Site Selection

Consider the following criteria when selecting a site to install the Arista NDR appliance(s):

- **Temperature and Ventilation:** For proper ventilation, install the Arista NDR appliance, where there is ample airflow to the front and back of the Arista NDR appliance. Maintain an ambient temperature between 0° and 40°C.

Warning:



Do not operate the Arista NDR appliance in an area where the ambient temperature exceeds 40°C (104°F) to prevent overheating.

Pour éviter que l'apppliance Arista NDR ne surchauffe, ne l'utilisez pas dans une zone où la température ambiante est supérieure à 40 °C (104 °F).

- **Rack Space:** Install the Arista NDR appliance in a 19" rack or cabinet. The accessory kit provides mounting brackets for a four-post rack.

When mounting the Arista NDR appliance in a partially filled rack, load the rack from bottom to top, with the heaviest equipment at the bottom. Load the Arista NDR appliance at the bottom if it is the only item in the rack.

- **Other Requirements:** Select a site where liquids or objects cannot fall onto the equipment and foreign objects are not drawn into the ventilation holes. Verify these guidelines are met:
 - Maintain clearance areas in the front and rear panels for unrestricted cabling and switch and control accessibility.
 - All front and rear panel indicators can be easily seen and read.



Note: The Status indicators and control functions are shown in [Status Indicators Appendix A](#).

- Power cords can reach from the power outlet to the connector on the rear panel.

Warning:



Remove all power connections to fully de-energize the unit after it is powered off using the power switch.

Toutes les connexions électriques doivent être retirées pour mettre complètement l'unité hors tension après sa mise hors tension à l'aide de l'interrupteur d'alimentation.

2.2 Tools and Parts Required for Installation

Each Arista NDR appliance provides an accessory kit containing the parts required to install it. In addition to the accessory kit, the following tools and equipment are required to install the Arista NDR appliance:

- Screws or rack mounting nuts and bolts
- Screwdriver
- Four post rails
- Phillips head screw driver



Note: No additional equipment is required for installation into tool-less four-post racks.

The accessory kit does not include screws for attaching the Arista NDR appliance to the equipment rack. When installing the appliance into an equipment rack with unthreaded post holes, nuts are also required to secure the device to the rack posts.

2.3 Electrostatic Discharge (ESD) Precautions

Observe these guidelines to avoid ESD damage when installing or servicing Arista NDR appliances:

- Assemble or disassemble equipment only in a static-free work area.
- Select a conductive work surface (such as an anti-static mat) to dissipate static charge accumulation.
- Wear a conductive wrist strap to dissipate any static charge accumulation.
- Minimize handling of assemblies and components.
- Keep replacement parts in their original static-free packaging until they can be handled with anti-static precautions.
- Remove all plastic, foam, vinyl, paper, and other static-generating materials from the work area.
- Select tools that do not generate ESD.

Rack Mounting an Arista NDR Appliance

This section discusses the rack mounting procedure identical to all Arista NDR appliances covered by this guide. Illustrations in this section depict the mounting of 1RU and 2RU appliances.

The following sections provide instructions for mounting 1RU and 2RU appliances:

- [Installing 1RU Arista NDR appliances](#)
- [Installing 2RU Arista NDR Appliances](#)

3.1 Installing 1RU Arista NDR appliances

Perform the following steps to install a 1RU Arista NDR appliance:

1. Identify the left and right outer rails by examining the ends, which bend outward. Slide the matching inner rails into the corresponding outer rails to be sure they are ready for installation.



Note: The rail set fits a four post rack with a depth of between 25.6 and 33 in.

2. Position the alignment pins in the rear rail (2) with the hole at the end of the slot in the front rail (1), and slide the front section into the rear section (3).

Figure 3-1: Installing Rails

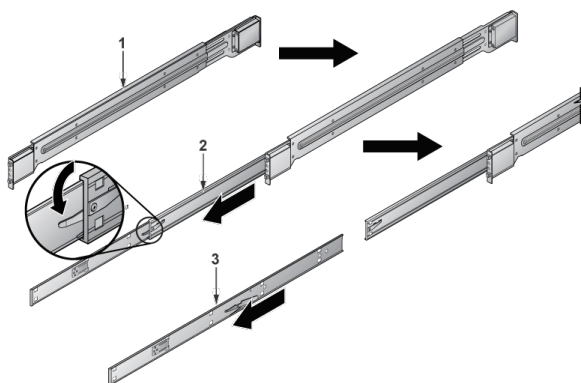

Note: Each end of the assembled outer rail includes a bracket with alignment pins to fit into your rack holes.

3. Position the alignment pins on the front end of the rail with the holes on the front of the rack (C). Push the rail into the rack until the quick-release bracket snaps into place, securing the rail to the rack.



Note: Mount the rails horizontally, referencing the number labels on the rack's vertical bars.

4. Adjust the rail to reach just past the full depth of your rack.

-
5. Position the alignment pins on the rear end of the rail to the holes on the rack (D) and push the rail into the rack until the quick-release bracket snaps into place, securing the rail to the rack.
 6. Repeat the procedure for the other outer rail assembly.

Figure 3-2: Rack Rails Installed



Note: Ensure that the appliance includes the inner rails and inner rail extensions and that the outer rails are installed on the rack.

7. Align the appliance's inner rails with the front of the outer rails on the rack.
8. Slide the appliance rails into the rack, keeping the pressure even on both sides.

Figure 3-3: Installing the Appliance into a Rack

Note: You may have to select the bracket clips while inserting the appliance. When you fasten the server into the rack, ensure you hear the bracket clip engage with an audible click.

9. Secure the front of the server to the rack with thumbscrews.

3.2 Installing 2RU Arista NDR Appliances

Perform the following steps to install a 2RU Arista NDR appliance:

1. Detach the inner rails from the outer rails.

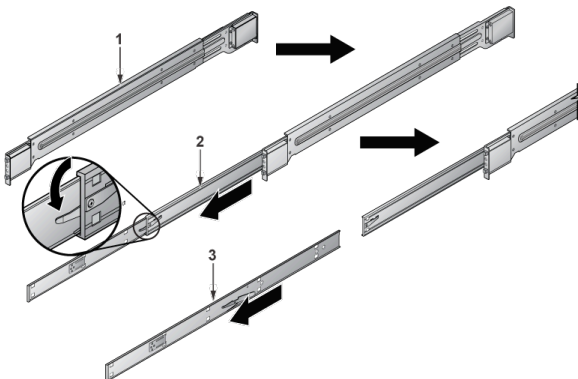
Figure 3-4: Detaching Rails

2. Install the inner rails to the side of the appliance.

Figure 3-5: Install inner rails

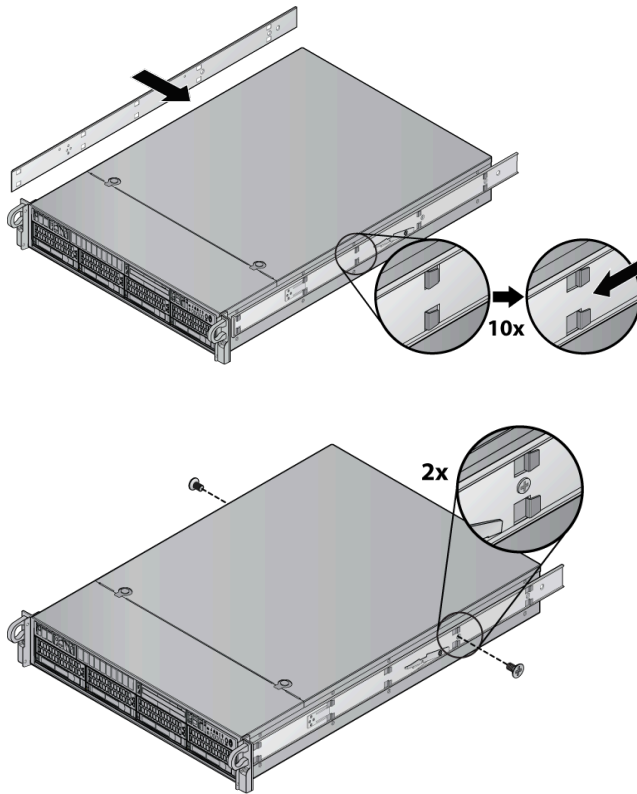

3. Press the button to slide the rail in.

Figure 3-6: Slide the Rail in

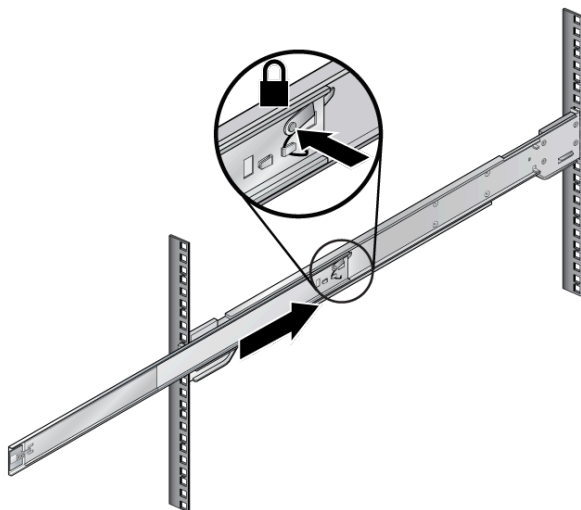

 **Note:** Ensure the rails are attached to the same rack position number in all four corners.

4. Slide the outer rail into the front rack.

Figure 3-7: Assembling Outer Rails

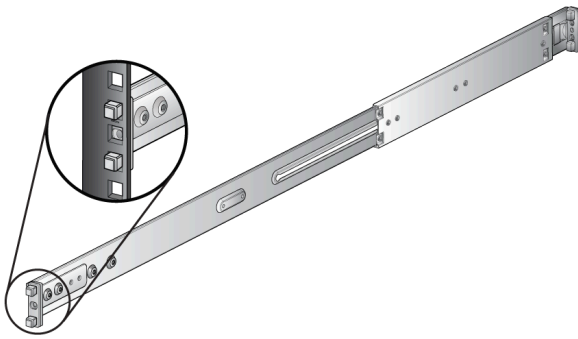

5. Secure the rack to the rail with screws.

Figure 3-8: Screw in the rails

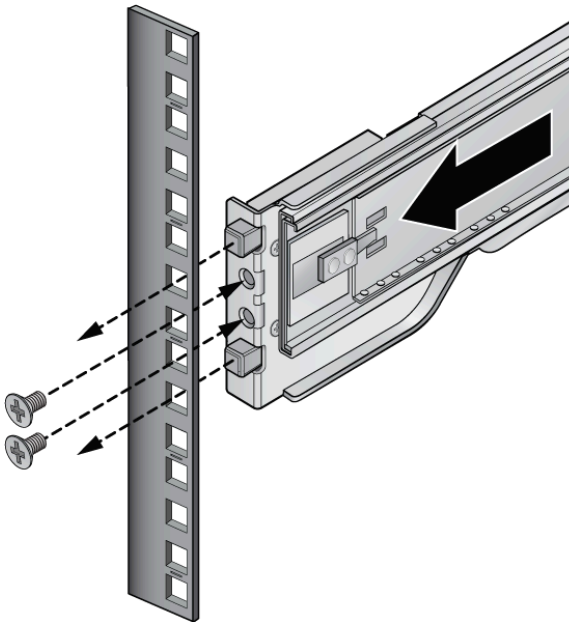

6. Repeat the previous step to mount four corners.

Figure 3-9: Mount all Four Corners

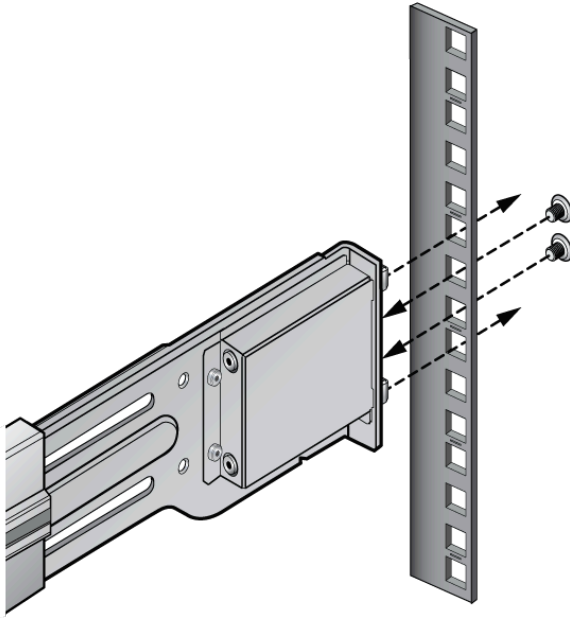

7. Insert the appliance rails into the rack rails and slide the appliance in.

Figure 3-10: Positioning the Appliance

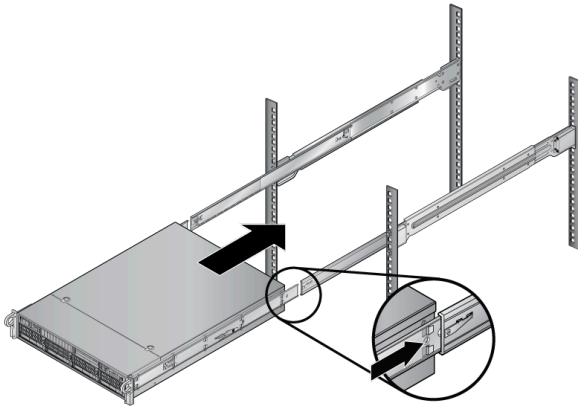

8. Install screws into the handles to secure the appliance.

Figure 3-11: Securing the Appliance

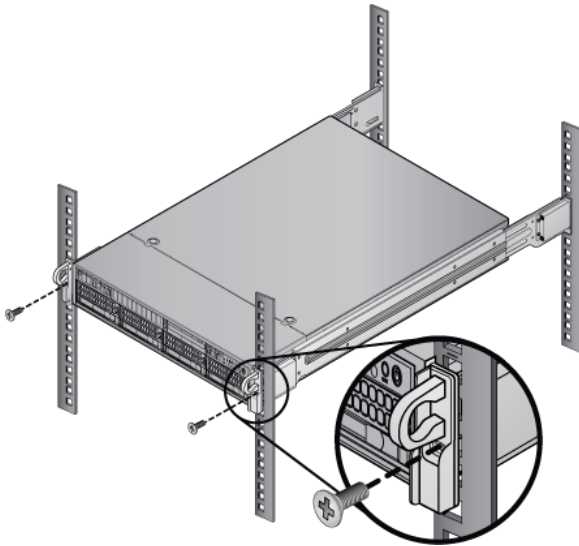

3.3 Installing S40 1RU Arista NDR Appliances

Perform the following steps to install the S40 1RU Arista NDR appliance:

1. Pull the inner rails out of the rack until they lock into place.

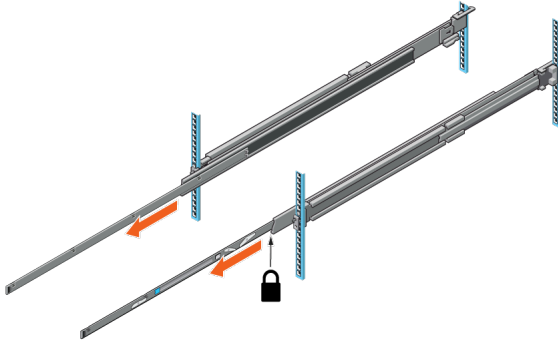

2. Locate the rear rail standoff on each side of the system and lower them into the rear J-slots on the slide assemblies.
3. Rotate the system downward until all the rail standoffs are seated in the J-slots.

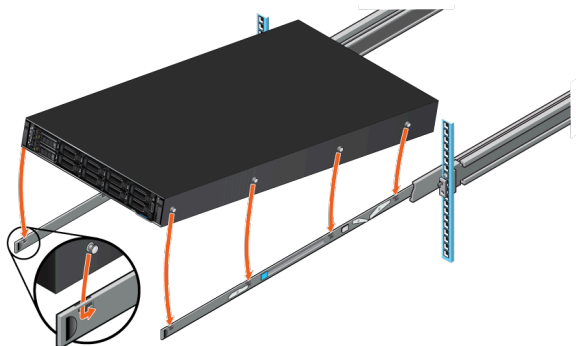

4. Push the system inward until the lock levers click into place.
5. Pull the blue slide release lock tabs forward on both rails and slide the system into the rack until the system is in the rack.

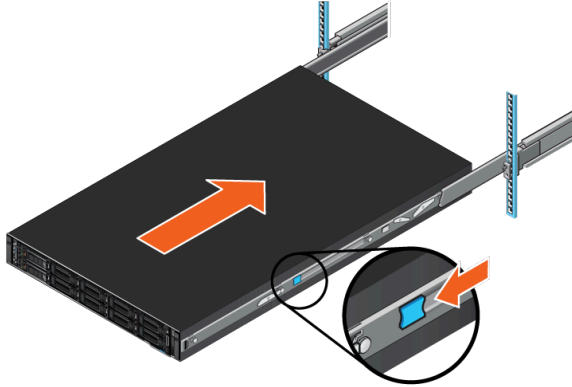

3.3.1 Installing the S40 Arista NDR Appliance Bezel

Perform the following steps to attach the Arista bezel to the front of the enclosure.

1. Align and insert the tabs on the bezel into the slots on the system.

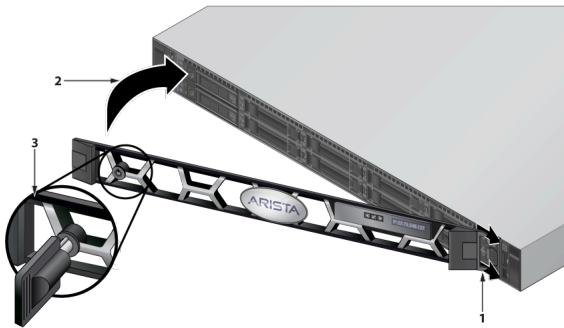

2. Press the bezel until the release button clicks in place.
3. Lock the bezel.

3.3.2 Installing the Cable Management Arms

If you plan to use the Cable Management Arms (CMA), install the CMAs after installing the enclosure in the rack.

Perform the following steps to install the CMAs:

1. Install two CMA attachment brackets on the left rails.

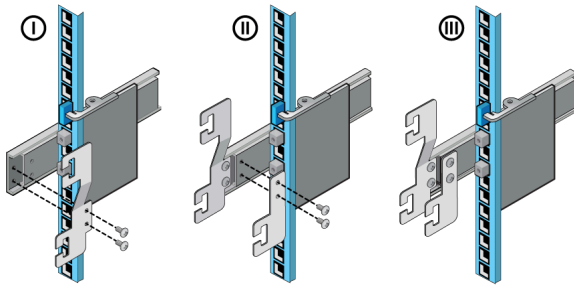

2. Install two CMA attachment brackets on the right rails.

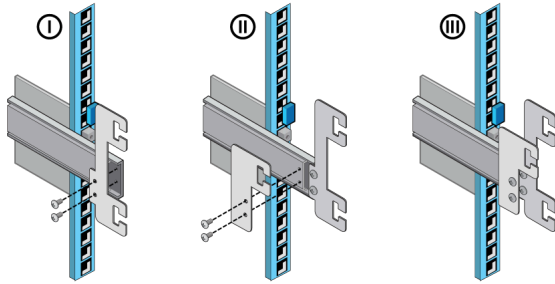

3. Perform the following steps to install the upper CMA:

- a. On the right side of the rear of the enclosure, align the two connectors on the CMA with the attachment brackets on the rails.
- b. Insert the CMA connectors into the brackets until you hear an audible click.
- c. Swing the extension arm and align it with the left rail bracket.
- d. Insert the connector on the CMA to the attachment bracket on the left rail.

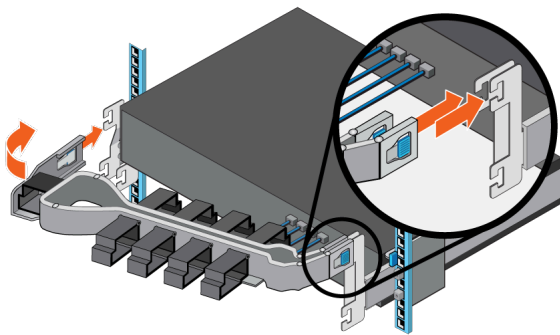

4. Perform the following steps to install the lower CMA:

- a. On the left side of the rear of the enclosure, align the two connectors on the CMA with the attachment brackets on the rail.
- b. Insert the CMA connectors into the brackets until you hear an audible click
- c. Swing the extension arm and align it with the right rail bracket.
- d. Insert the connector on the CMA to the attachment bracket on the right rail.

3.4 Installing STR 4RU Arista NDR Appliances

Perform the following steps to install the STR 4RU Arista NDR appliance:

1. Remove the inner rails from the rail kit and install them on the chassis.
2. Pull the inner rails forward and remove it out from the rail kit.

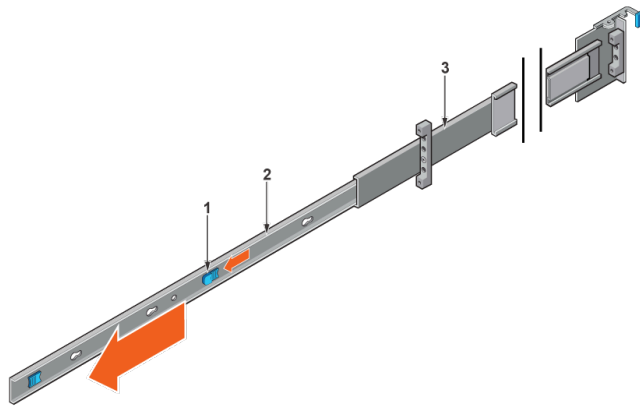

1 Tab

2 Inner rails

3 Outer rails

3. Push the tab and slide the middle rails back until they lock into place.
4. Attach the inner rails to the chassis by aligning the keyhole on the rail with the standoffs on the chassis and sliding forward until they lock into place.

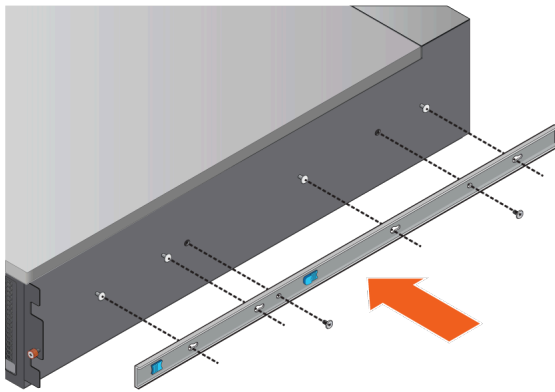

Note: Verify all the keyholes on the rails are aligned with the rail standoffs on the chassis. Improper installation of the rails may damage the rails or cause the chassis to fall when extended.

5. Secure the rails by installing two screws on each side of the enclosure.

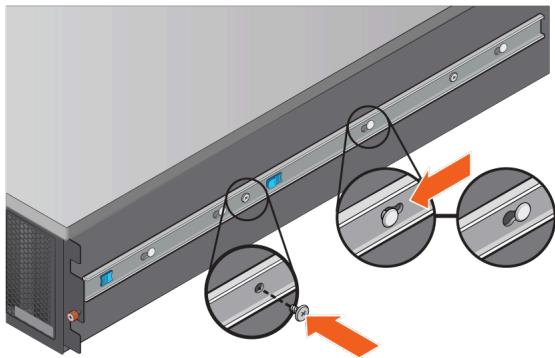

6. Identify the rack holes for installing the rails and install the provided nuts on them. Use square or circular nuts depending on the type of rack post. Attach the right rail to the back post of the rack.

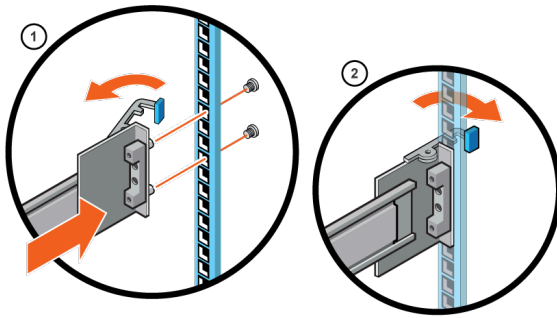

- a. Align the right rail with the holes on the back post of the rack.
 - b. Push the rail back while holding the latch open.
 - c. Once the rail engages to the rack post, release the latch to lock the rail in place.
 - d. Insert the screws and secure the rail to the back post.
7. Attach the right rail to the front post of the rack.

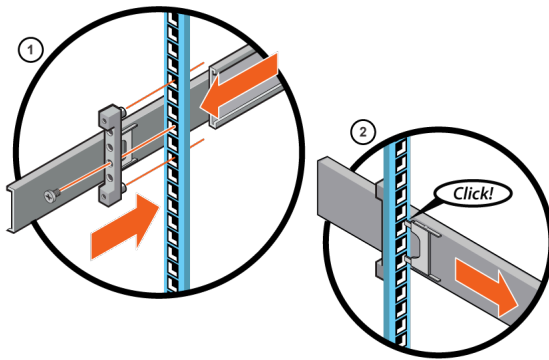

- a. Extend the rail to fit between the front and rear rack posts.
 - b. Pull the rail backward to engage the rail to the rack post.
 - c. Insert the screws and secure the rail to the front post.
8. Repeat the previous steps to install the left rail.
9. Pull the middle rails out of the rack until they lock into place. Ensure that the ball bearing retainer is located at the front of the middle rail.
10. Lift the enclosure and slide it onto the rails.

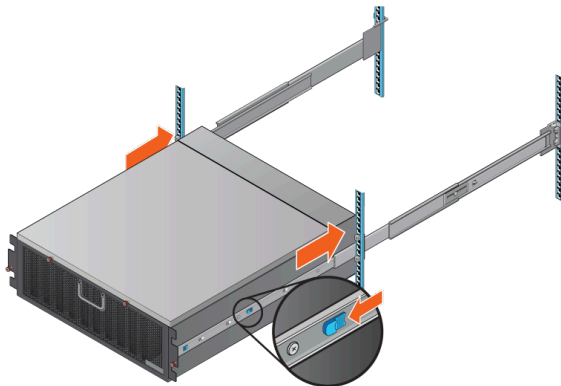

11. When hit a stop, pull the blue release tab on the inner rails.
12. Secure the enclosure to the rack using the thumbscrews on the rack mount ears on both sides of the enclosure.

3.4.1 Installing STR Arista NDR Appliances Hard Disk Drives

Perform the following steps to install hard disk drives:

1. Insert the drive into the drive carrier with the connector end of the drive at the back.

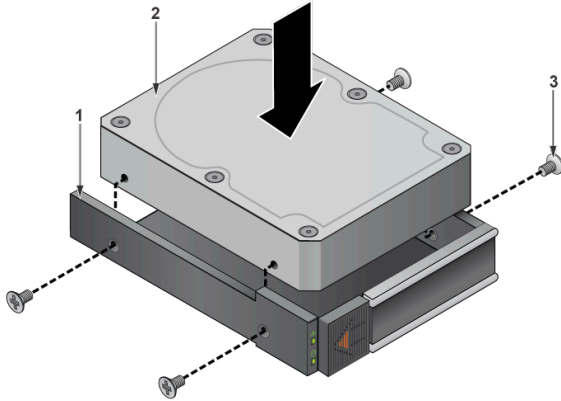

1 Drive carrier

2 Drive

3 screws

2. Install four screws to secure the drive to the drive carrier.
3. Loosen the thumbscrews on the rack mount ears and pull out the enclosure from the rack.
4. Loosen the two thumbscrews that attach the system cover to the chassis.



Note: When you open the system cover, it must be closed within twelve minutes to prevent the enclosure from overheating.

5. Pull the system cover forward and lift it out of the enclosure.

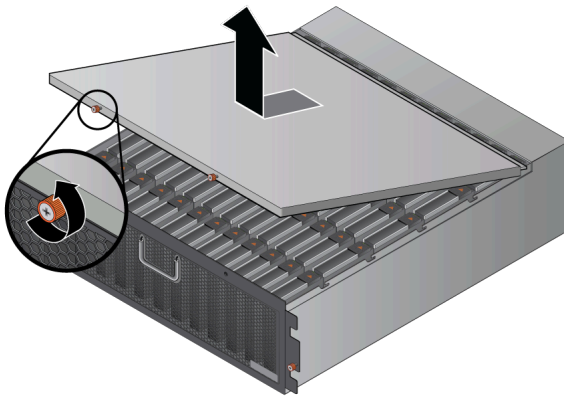

6. Open the release handle on the drive carrier.
7. Align the drive carrier with the target slot and gently push the drive carrier into the slot.

Note: Consider the following ideal installation pattern for providing the best airflow and thermal performance:



- Populate the slots from the rear of the enclosure first, closest to the PSU.
- The minimum number of drives in an enclosure is 12.
- If it is not possible to fill a complete row, insert drive blanks to fill the empty slots in each row.
- Do not partially populate multiple rows. Fill each row before proceeding to the next row.

8. Close the release handle to lock the drive in place.

9. Verify that the activity light flashes to indicate that the spin-up sequence has begun.

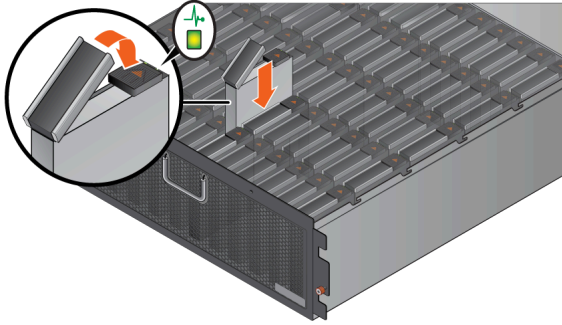

Cabling the Appliance

For all Arista NDR appliances, connect the management port to your network. For the All-in-One and Sensor appliances, connect the packet capture port to the span port of your switch.

Cable the Nucleus appliance in one of the following ways as appropriate for your installation:

- For a single nucleus installation, interconnect ports are unused and should not be connected.
- For a dual nucleus installation, connect a network cable from the first nucleus interconnect port to the second nucleus interconnect port.
- For a nucleus cluster with more than two nucleus appliances, attach a network cable from one of the interconnect ports from each nucleus and connect it to the supplied Arista switch.

Refer to the [Rear Panel](#) section for the information on ports.

Configuring the Arista NDR Platform

After the appliances are physically installed and cabled up, the next step is software configuration of the individual Arista NDR appliances, which, after configured, will combine to become the Arista NDR Platform:

1. [Connecting to the Admin CLI](#)
2. [Configuring the Appliance](#)
3. [Verifying the Configuration](#)

5.1 Connecting to the Admin CLI

You can access the CLI by physically connecting a monitor and a keyboard to the Arista NDR appliance SKU. The following screen is displayed:

Figure 5-1: Command Prompt Window

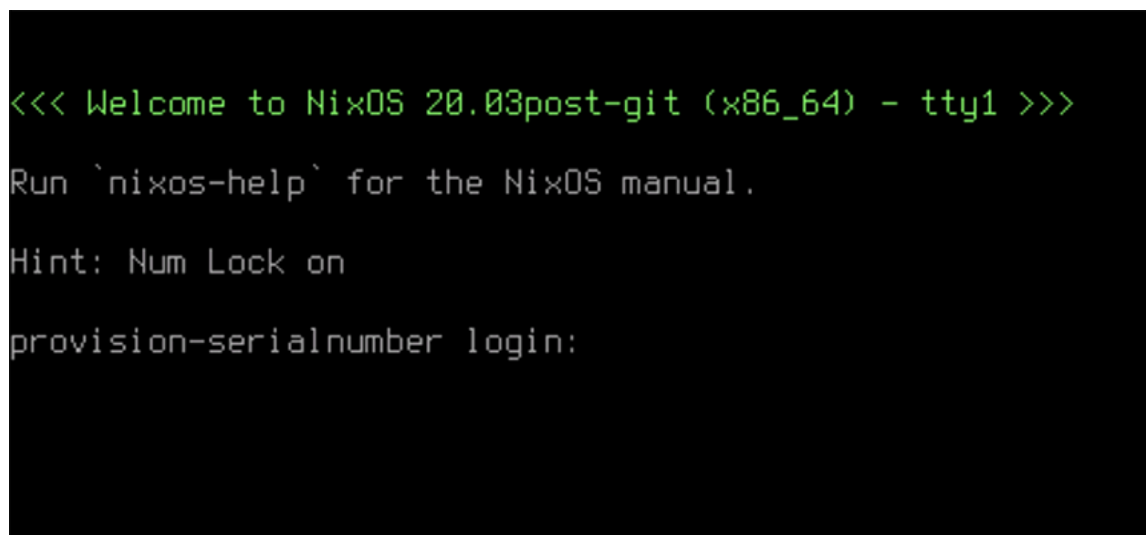

```
<<< Welcome to NixOS 20.03post-git (x86_64) - tty1 >>>
Run `nixos-help` for the NixOS manual.
Hint: Num Lock on
provision-serialnumber login:
```



Note: Enter the username as `admin` and the password provided by the [Arista technical support](#).

5.2 Configuring the Appliance

Configure the following networking parameters in Arista NDR appliances:

- [Configuring the Management Interface](#)
- [Configuring DNS](#)

- [Configuring NTP](#)
- [Configuring Proxy](#)
- [Configuring IPMI Ethernet Interface](#)



Note: If configuring all networking parameters simultaneously, you can run the **apply** and **reboot** commands at the end of all configurations instead of running them for each.

5.2.1 Configuring the Management Interface

Perform the following steps to configure the management interface:

1. Enter the **set interface static <ip> <netmask> <default gateway>** where specified variables denote the following values:
 - **<ip>** - IP address of the management interface
 - **<netmask>** - Netmask of the network (for example, 255.255.255.0)
 - **<default gateway>** - Default gateway of the network

CLI displays the following prompt:

```
Applying network settings now might cause the network to disconnect.  
If you do not apply network settings now, network settings will  
take effect only after running "apply" and "reboot"  
Do you want to apply network settings now? (y/n)
```

2. Enter **y**.
3. Enter the **apply** command to apply the changes.
4. If no further configuration changes are required, enter the **reboot** command to restart the device.

5.2.2 Configuring DNS

You must set up Domain Name Servers (DNS) in Arista NDR appliances to use hostname instead of IP addresses. Perform the following steps to configure DNS:

1. Enter the **set dns nameservers** command.
An interactive prompt will ask for primary and secondary servers.
2. Enter the primary and secondary DNS.
3. Enter the **apply** command to apply the changes.
4. If no further configuration changes are required, enter the **reboot** command to restart the device.

5.2.3 Configuring NTP

You must configure the Network Time Protocol (NTP) in all of your Arista NDR appliances to ensure the accuracy of the appliance clock. Perform the following steps to configure NTP:

1. Enter the **set ntp servers** command.
An interactive prompt will ask for primary and secondary servers.
2. Enter the primary and secondary servers.
3. Enter the **apply** command to apply the changes.

4. If no further configuration changes are required, enter the `reboot` command to restart the device.

5.2.4 Configuring Proxy

Arista NDR appliances support outgoing connection using the customer's proxy (without SSL interception). Perform the following steps to configure proxy for outgoing connections:

1. Enter the `set proxy servers` command.
2. Enter the required details when an interactive prompt asks for the following information:
 - **Host:** The IP address of the proxy server.



Note: You may enter the hostname instead of the IP address if DNS already has been configured, applied, and the system was rebooted.

- **Port:** The port of the proxy server
 - **Username / password:** Enter the credentials if the proxy requires authentication.
3. Enter the `apply` command to apply the changes.
 4. If no further configuration changes are required, enter the `reboot` command to restart the device.

5.2.5 Configuring IPMI Ethernet Interface

Arista NDR appliances provide a dedicated network interface for the Intelligent Platform Management Interface (IPMI). Perform the following steps to configure IPMI:

1. Enter the `set ipmi config` command.
2. Enter the required details when an interactive prompt asks for the following information:
 - **IPMI Interface Mode (static or dhcp):** Sets the interface to either DHCP or Static mode.



Note: We recommend setting the interface to static mode.

- **IP:** The static IP address of the interface.
- **Subnet Mask:** The subnet mask of the network. For example, 255.255.255.0
- **Default Gateway:** The default gateway of the network
- **Would you like to change the ipmi admin password:** : Enter `y` to configure the IPMI password, else enter `n`.

Note:



- The default password is printed on a label on the appliance.
- The password can be shared if it is configured by the installation team.
- The password should not exceed 20 characters and must contain numbers, uppercase letters, and symbols.

3. Enter the `apply` command to apply the changes.
4. If no further configuration changes are required, enter the `reboot` command to restart the device.

5.3 Verifying the Configuration

After the reboot is complete, log in to the CLI and enter the `show networking` command to verify the current configuration.

This command displays networking configuration settings for the management and IPMI Ethernet interfaces. Ensure that the network settings are correct.

Status Indicators

The Status Indicators section discusses the following topics:

- [Control Panel Indicators](#)



Note: The control panel LEDs are located on the right side of the appliance, and display system, fan, and power supply status. They are labeled in either [Figure A-1: DCA-NDR-S100MB, DCA-NDR-S1](#) or [Figure A-2: DCA-NDR-A5, DCA-NDR-NB10, DCA-NDR-CC, DCA-NDR-S5, DCA-NDR-S10](#).

- [Front Panel Status Indicators](#)
- [Rear Panel Status Indicators](#)

A.1 Control Panel Indicators

Front panel LEDs are located on the upper right corner of the device for 1RU appliances.

Figure A-1: DCA-NDR-S100MB, DCA-NDR-S1

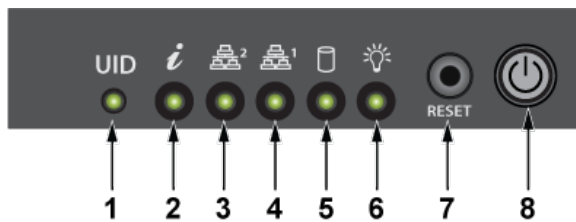

- | | | |
|----------------|-------------------|-------------|
| 1 UID LED | 2 Information LED | 3 NIC2 LED |
| 4 NIC1 LED | 5 HDD LED | 6 Power LED |
| 7 Reset button | 8 Power button | |

Front panel LEDs are located on the lower left corner of the device for the 2RU appliance.

Figure A-2: DCA-NDR-A5, DCA-NDR-NB10, DCA-NDR-CC, DCA-NDR-S5, DCA-NDR-S10

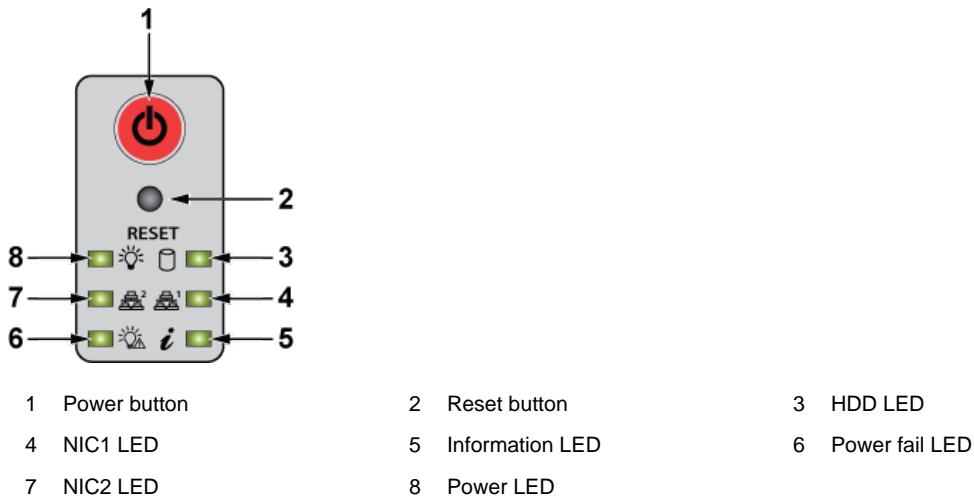

A.2 Front Panel Status Indicators

The two LED indicators next to each hard drive carrier are activity and status indicators.

Figure A-3: Drive Status Indicators

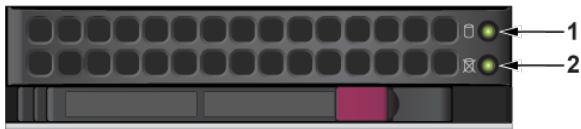

Num	Label	Indication	Meaning
1	Storage Activity LEDs	Blinking	Actively transmitting or receiving data
		Off	No transmit of data
2	NVMe Activity LEDs	Solid blue	Active connection
		Off	No connection
3	Status	Off	Not in use

Note: In non-RAID configurations, the status LEDs are always off.

DCA-NDR-S40

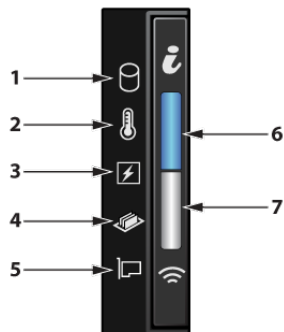

Num	Label	Indication	Meaning
1	Drive indicator	Amber: Solid	Drive error
2	Temperature indicator	Amber: Solid	Thermal error
3	Electrical indicator	Amber: Solid	Electrical error
4	Memory indicator	Amber: Solid	Memory error
5	PCIe indicator	Amber: Solid	PCIe card error
6	System health and system ID indicator	Blue: Solid	System is powered on and healthy; but system ID mode is not active.
		Blue: Blinking	System ID mode is active
		Amber: Solid	System is in fail-safe mode
		Amber: Blinking	System is experiencing a fault
7	IPMI Quick Sync 2 indicator	Off: Default state	IPMI Quick Sync 2 feature is powered off
		White: Solid	IPMI Quick Sync 2 is ready to communicate
		White: Blinks rapidly	Data transfer activity
		White: Blinks slowly	Firmware update is in progress
		White: Blinks 5 times rapidly and then powers off	The IPMI Quick Sync 2 feature is disabled
		Amber: Solid	The system is in fail-safe mode
		Amber: Blinking	IPMI Quick Sync 2 hardware is not responding properly.

DCA-NDR-STR

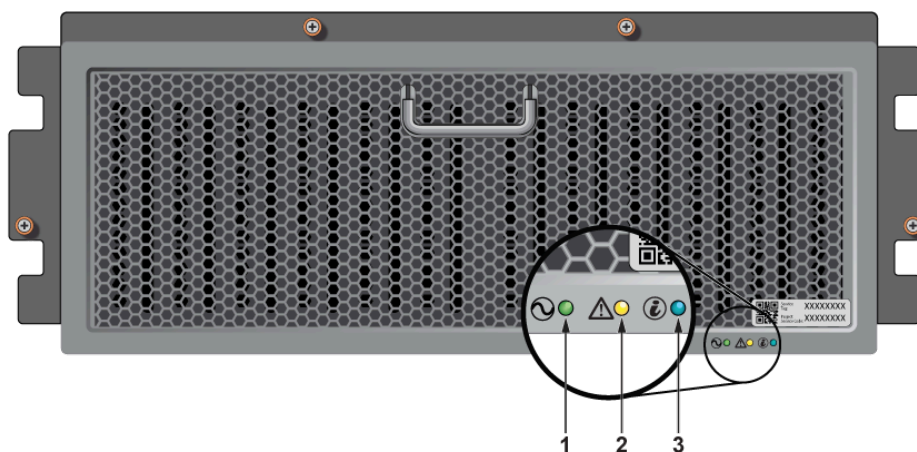

Num	Label	Indication	Meaning
1	Power status LED	Green: Solid	Operational
2	System status LED	Amber: Blinking	Hardware fault
3	Enclosure ID	Blue: Blinking	Identifying enclosure

Figure A-4: DCA-NDR-STR Drive Carrier LEDs



Num	Label	Indication	Meaning
1	Drive activity LED	Green: Blinking	<ul style="list-style-type: none"> 500 msec on, 500 msec off - Drive is spinning up or spinning down. 100 msec on, 100 msec off - Drive activity 50 msec on, 50 msec off - Active/idle/standby power condition
2	Drive status LED	Amber: Blinking	<ul style="list-style-type: none"> 150 msec on, 150 msec off - Drive failure two sec on, one sec off - Identifying drive 400 msec on, 100 msec off - Drive rebuilding Off - Drive online/drive not present/drive offline

A.3 Rear Panel Status Indicators

The two LED indicators above either side of each management port and each packet capture port are link and activity indicators.

DCA-NDR-S100MB, DCA-NDR-S5, DCA-NDR-S10, DCA-NDR-A5 Packet Capture Port LEDs

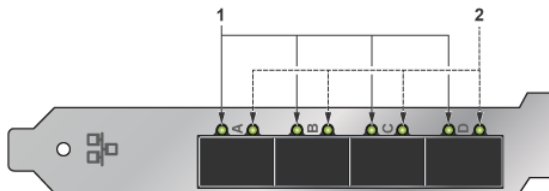

Num	Label	Indication	Meaning
1	Link LEDs	Green	Linked at 10 Gb
		Yellow	Linked at 1 Gb
2	Activity LEDs	Blinking	Actively transmitting or receiving data
		Off	No link

DCA-NDR-NB10/DCA-NDR-CC Interconnect Port LEDs

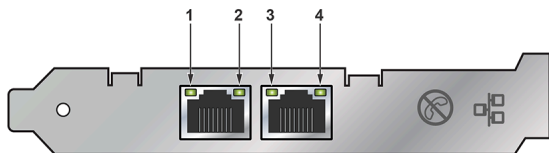

Num	Label	Indication	Meaning
1	Link	Off	Not linked to the LAN
		Green	Linked at 10 GB
		Yellow	Linked at 1 GB
2	Activity	Off	No link
		Blinking	Actively transmitting or receiving data

Management Port LEDs

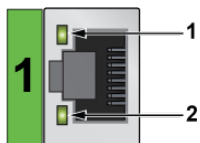

1 Link LED

2 Activity LED

Num	Label	Indication	Meaning
1	Activity/Link	Green: Solid	The adapter is connected to a valid link partner.
		Green: Flashing	Data activity
		Off	No link
2	10 = Off 100 = Green 1000 = Yellow	Off	10 Mbps
		Green	100 Mbps
		Yellow	1000 Mbps

IPMI Ethernet Port LEDs

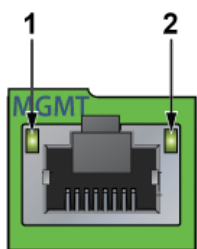

1 Link LED

2 Activity LED

The green, amber, or off indicates the speed of the connection. The amber LED indicates activity.

Table 2: IPMI Link LEDs

LED Color	Definition
Amber: Solid	1 Gb/s
Green: Solid	100 Mb/s
Off	No connection or 10 Mb/s

DCA-NDR-S40

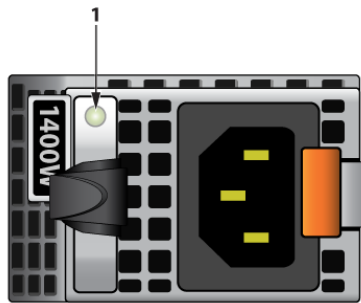

Num	Label	Indication	Meaning
1	AC PSU status indicator	Green	A valid power source is connected to the PSU and the PSU is operational
		Amber: Blinking	An issue with the PSU
		Powered off	The power is not connected to the PSU
		Green: Blinking	The firmware of the PSU is being updated
		Blinking green and powers off	When hot-plugging a PSU, it blinks green five times at a rate of 4 Hz and powers off. This indicates a PSU mismatch due to efficiency, feature set, health status, or supported voltage.

DCA-NDR-STR

Figure A-5: EMM Indicators

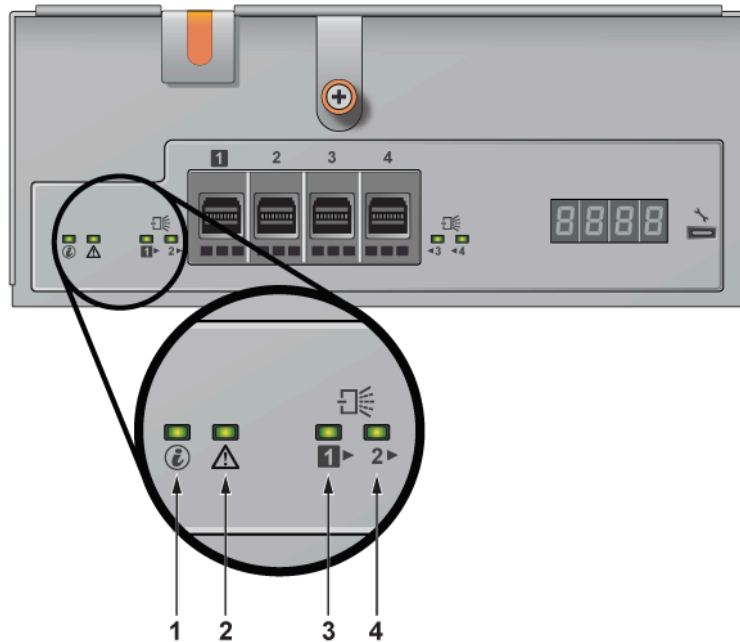

Table 3: EMM and PSU Indicators

Num	Label	Indication	Meaning
1	EMM ID	Blue	<ul style="list-style-type: none"> Blinking (on for one second and off for one second): Identifying EMM Off: Normal operation
2	EMM Status	Solid Green	Normal operation
		Blinking Amber	EMM failure - On for two seconds and off for one second
3	Mini-SAS HD status for Mini-SAS HD ports 1	Green	<ul style="list-style-type: none"> Solid - port link is up Blinking (on for one second and off for one second) - Identifying
		Amber	<ul style="list-style-type: none"> Solid - port link is up, but with degraded speed Blinking (on for two seconds and off for one second) - Fault on the port
4	Mini-SAS HD status for Mini-SAS HD ports 2	Green	<ul style="list-style-type: none"> Solid - port link is up Blinking (on for one second and off for one second) - Identifying
		Amber	<ul style="list-style-type: none"> Solid - port link is up, but with degraded speed Blinking (on for two seconds and off for one second) - Fault on the port

Figure A-6: PSU Indicators

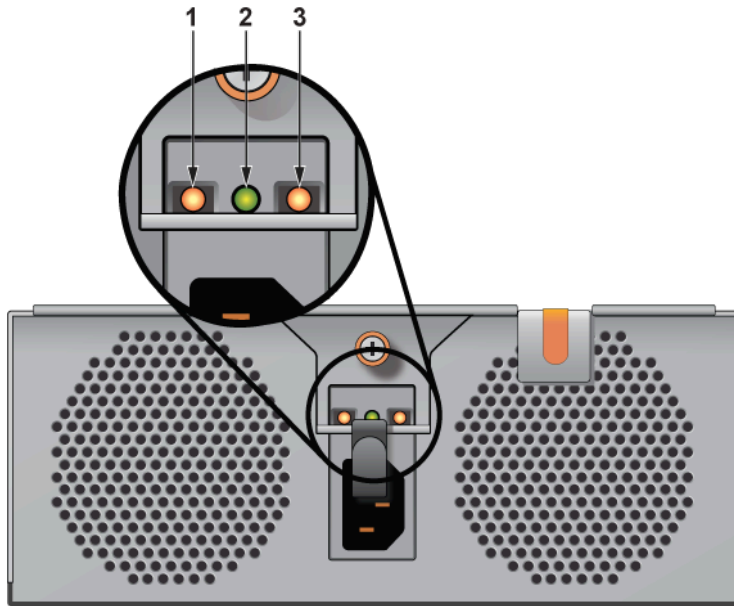

Table 4: PSU Indicators

Num	Label	Indication	Meaning
1	DC Power output	Green	<ul style="list-style-type: none"> On solid: Normal operation(output voltage is within specification). Off: No DC output or output voltage is out of specification.
2	AC Power input	Green	<ul style="list-style-type: none"> On: Normal operation (input voltage is within specification). Off: No AC input
3	PSU fault	Amber	<ul style="list-style-type: none"> Blinking (on for two seconds and off for one second): PSU failure Off: Normal operation

Parts List

The Parts List section discusses the following topics:

- [Rack Mount Parts](#)
- [Cables](#)

B.1 Rack Mount Parts

Each appliance provides an accessory kit that contains parts that are required to install the appliance. This appendix lists the installation parts contained in the accessory kit.

Figure B-1: Accessory Kit

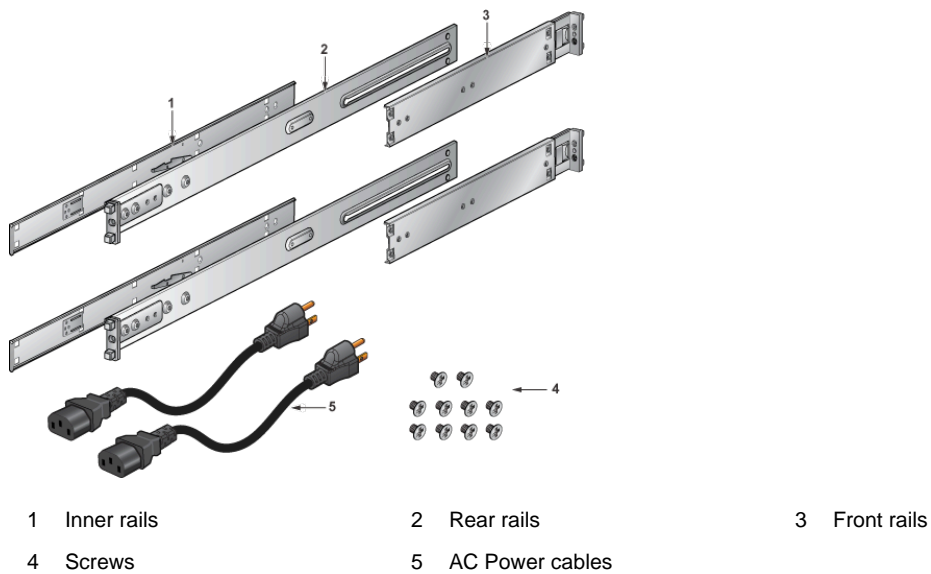

B.2 Cables

A pair of AC power cables (part number: NEMA 5-15p) is included in the accessory kit.

Warning:
 All provided power cables are for use with Arista products only.

警告

すべての電源コードは提供する製品で使用するためだけを目的としている。

電源コードの他の製品での使用の禁止

Aristaが提供するすべての電源コードは、Aristaの製品でのみ使用してください。

Front Panel

This section displays the front panel of all Arista NDR appliances this guide covers.

 **Note:** All devices are designed to fit into a 19" rack. The appearance may be different than those shown based on PSU and fan modules used.

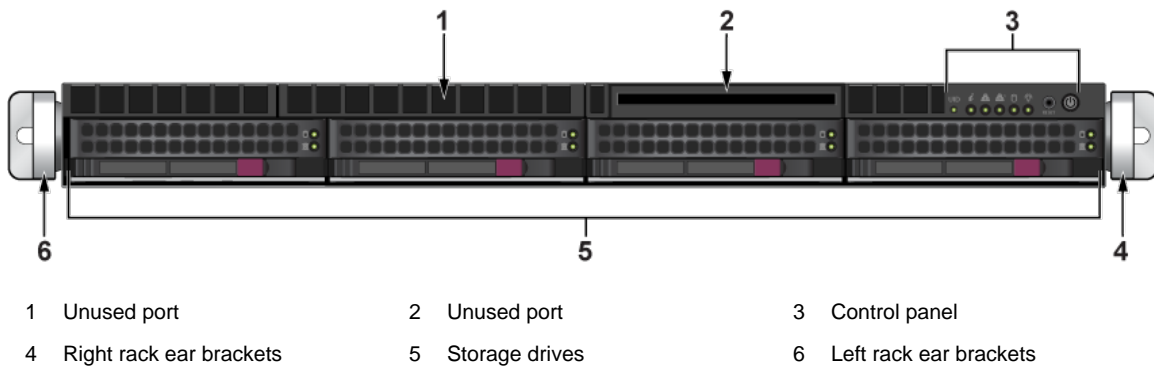

DCA-NDR-A5, DCA-NDR-NB10, DCA-NDR-CC, DCA-NDR-S5, DCA-NDR-S10

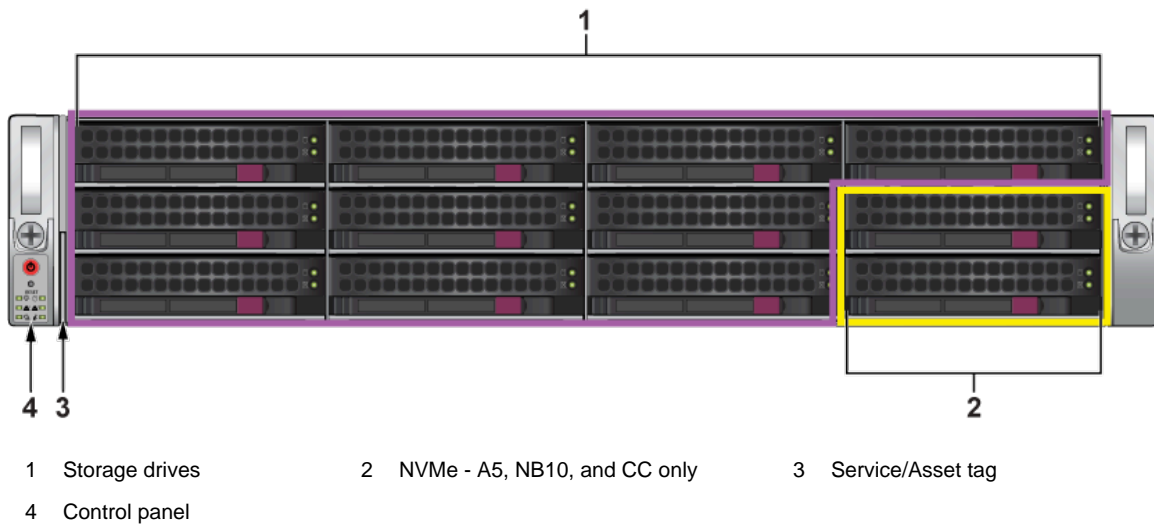

DCA-NDR-S40

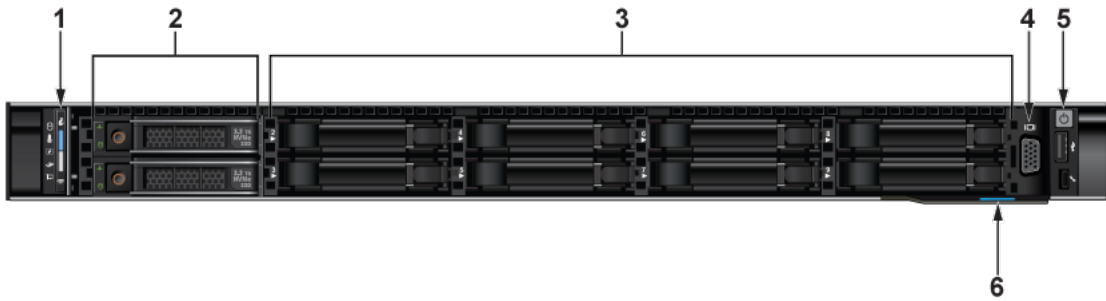

- 1 Status LEDs
- 2 Hot-Swap NVMe Bays
- 3 Blank Drive Bays
- 4 VGA Port
- 5 Power button and Ports
- 6 Express Service Tag

Figure C-1: DCA-NDR-S40 Bezel

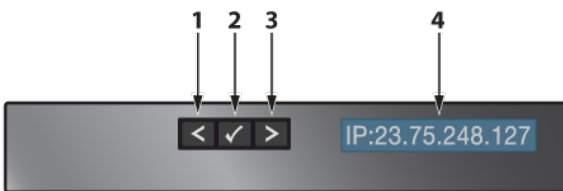

- 1 Moves the cursor back in one-step increments.
- 2 Selects the menu item that is highlighted by the cursor.
- 3 Moves the cursor forward in one-step increments.
- 4 LCD Display: Displays the system information, status, and error messages; or IPMI IP address.

DCA-NDR-STR

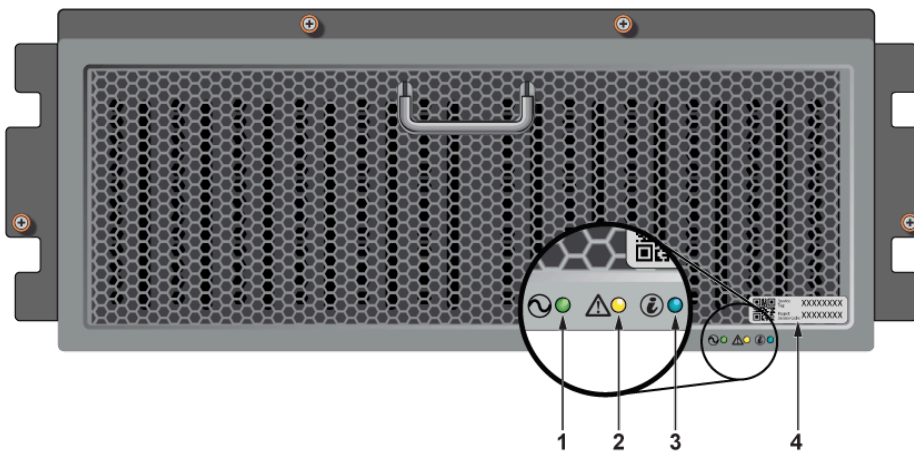

- 1 System power LED
- 2 System status LED
- 3 Enclosure ID LED
- 4 Express Service tag

Rear Panel

This section displays the rear panel of all Arista NDR appliances covered by this guide.

 **Note:** All devices are designed to fit into a 19" rack. The appearance may be different than those shown based on the PSU types and the modules used.

DCA-NDR-S100MB, DCA-NDR-S1

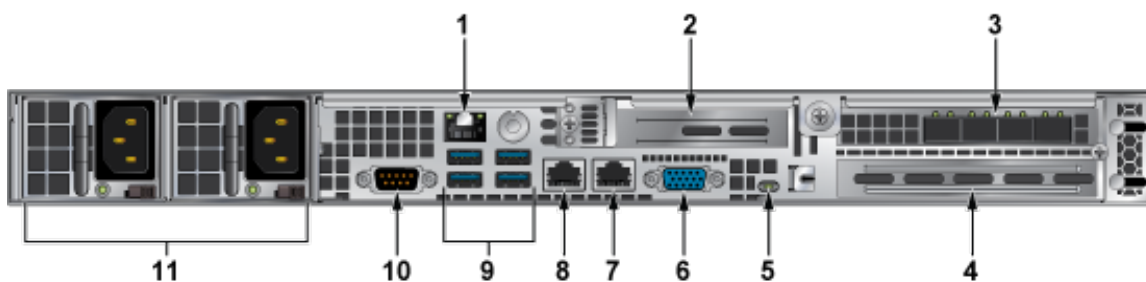

- | | | |
|-----------------|-------------------|------------------------|
| 1 Ethernet port | 2 Unused slot | 3 Packet capture ports |
| 4 Unused slot | 5 UID LED | 6 VGA |
| 7 Unused port | 8 Management port | 9 USB ports |
| 10 COM port | 11 Power supplies | |

DCA-NDR-A5, DCA-NDR-S5

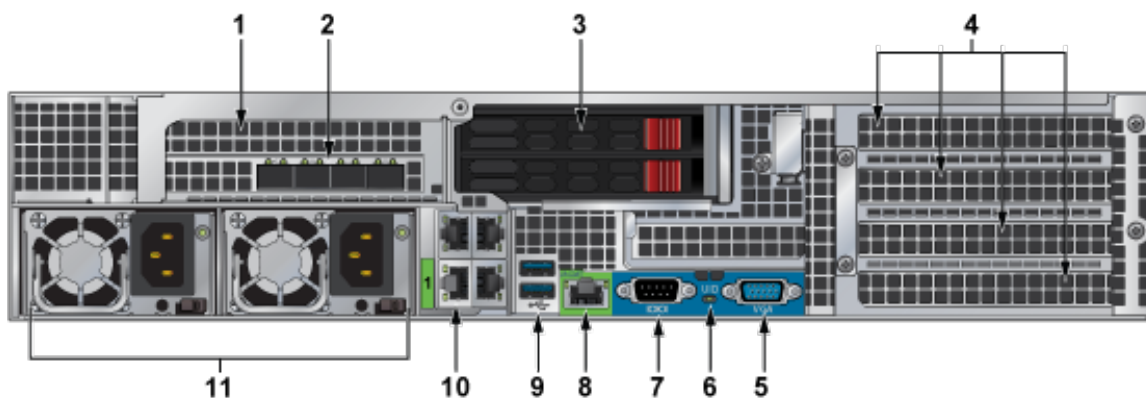

- | | | |
|--------------------|------------------------|--------------|
| 1 Unused slot | 2 Packet capture ports | 3 SSD drives |
| 4 Unused slots | 5 VGA | 6 UID LED |
| 7 COM port | 8 IPMI Ethernet port | 9 USB ports |
| 10 Management port | 11 Power supplies | |

DCA-NDR-S10

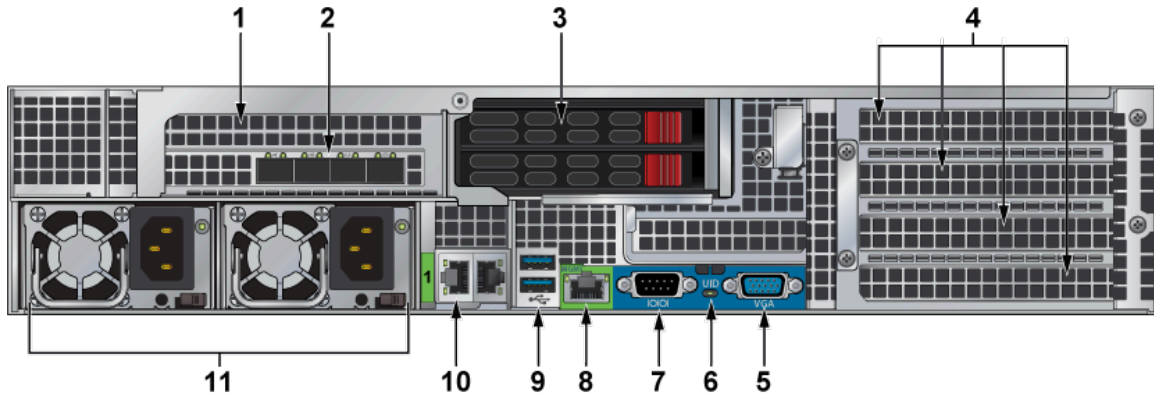

- | | | |
|--------------------|----------------------|--------------|
| 1 Unused slot | 2 Capture ports | 3 SSD drives |
| 4 Unused slots | 5 VGA | 6 UID LED |
| 7 COM port | 8 IPMI Ethernet port | 9 USB ports |
| 10 Management port | 11 Power supplies | |

DCA-NDR-NB10, DCA-NDR-CC

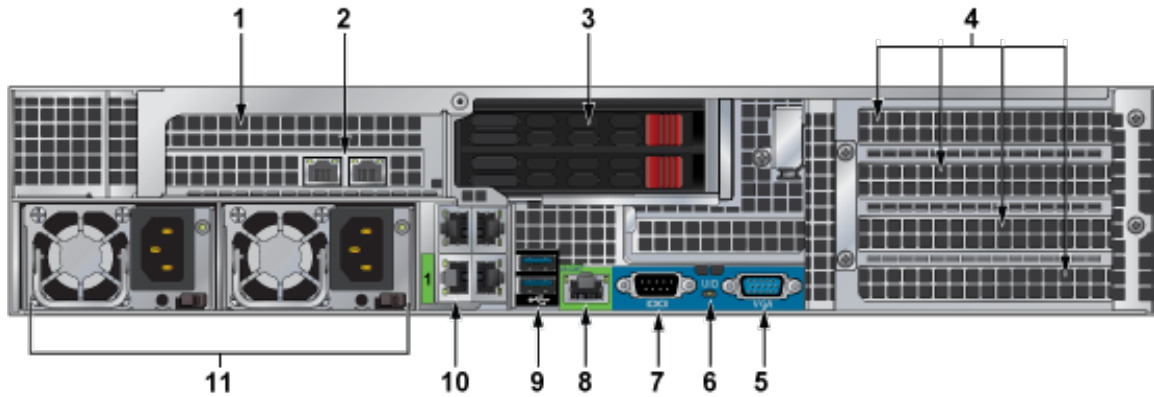

- | | | |
|---------------------|----------------------|--------------|
| 1 Unused slot | 2 Interconnect ports | 3 SSD drives |
| 4 Unused slots | 5 VGA | 6 UID LED |
| 7 COM port | 8 IPMI Ethernet port | 9 USB ports |
| 10 Management ports | 11 Power supplies | |

DCA-NDR-S40

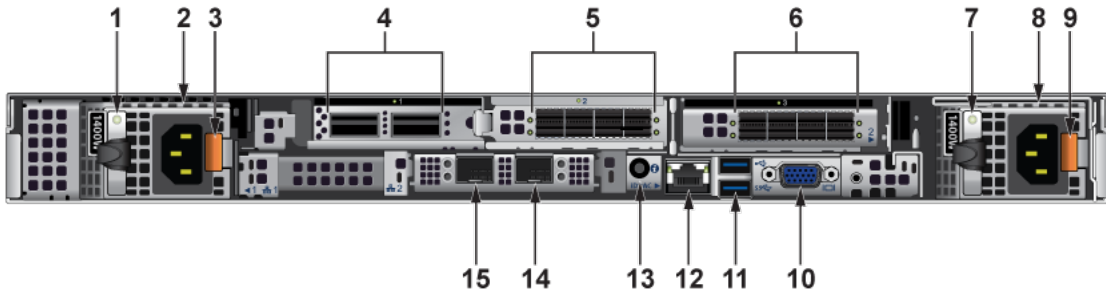

- | | | |
|---------------------------|---------------------------|---------------------------|
| 1 AC PSU status indicator | 2 Power supply plug | 3 Release latch |
| 4 100 Gbps QSFP28 Ports | 5 Storage connector ports | 6 Storage connector ports |
| 7 AC PSU status indicator | 8 Power supply plug | 9 Release latch |
| 10 VGA port | 11 USB port | 12 Ethernet port |
| 13 System ID LED | 14 10/25 Gbps SFP port | 15 10/25 Gbps SFP port |

DCA-NDR-STR

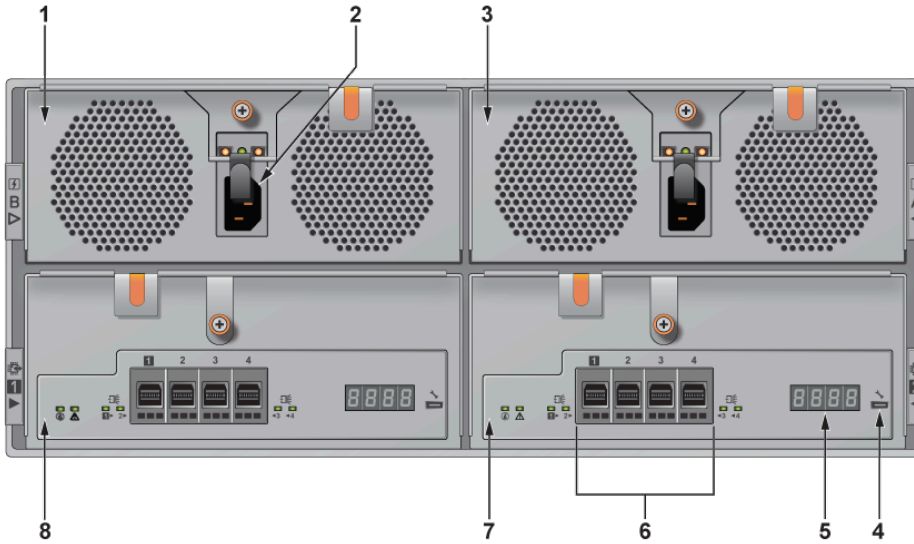

- | | | |
|-------------------------|---------------------|--------------------|
| 1 PSU B | 2 Power supply plug | 3 PSU A |
| 4 USB Type-C debug port | 5 7-segment LED | 6 Mini-SAS HD port |
| 7 EMM slot A | 8 EMM slot B | |

Regulatory Model Numbers

This section lists the regulatory model numbers (RMNs) for the product models of the Arista NDR appliances described in this document.

Table 5: Regulatory Model Numbers and Product Numbers

Regulatory Model Numbers (RMNs)	Product Numbers
815-R5H12	DCA-NDR-S100MB
815-R5H12	DCA-NDR-S1
829UAS-16	DCA-NDR-S5
829U-R16H12	DCA-NDR-S10
829UAS-16	DCA-NDR-A5
829UAS-16	DCA-NDR-NB10, DCA-NDR-CC
E95S	DCA-NDR-S40
TUMAE	DCA-NDR-STR