

# ARISTA

## Quick Start Guide

### 7280R4 Series Data Center Switches

DCS-7280R4-32PE  
DCS-7280R4K-32DE

DCS-7280R4K-32PE  
DCS-7280R4-64QC-10PE

DCS-7280R4-32DE  
DCS-7280R4K-64QC-10PE



<b>Headquarters</b>	<b>Support</b>	<b>Sales</b>
5453 Great America Parkway Santa Clara, CA 95054 USA +1-408-547-5500	+1-408-547-5502 +1-866-476-0000	+1-408-547-5501 +1-866-497-0000
<a href="http://www.arista.com/en/">www.arista.com/en/</a>	<a href="mailto:support@arista.com">support@arista.com</a>	<a href="mailto:sales@arista.com">sales@arista.com</a>

© Copyright 2026 Arista Networks, Inc. All rights reserved. The information contained herein is subject to change without notice. The trademarks, logos, and service marks ("Marks") displayed in this documentation are the property of Arista Networks in the United States and other countries. Use of the Marks is subject to the Arista Networks Terms of Use Policy, available at [www.arista.com/en/terms-of-use](http://www.arista.com/en/terms-of-use). Use of marks belonging to other parties is for informational purposes only.

# Contents

- Chapter 1: Overview..... 1**
  - 1.1 Scope..... 1
  - 1.2 Receiving and Inspecting the Equipment..... 1
  - 1.3 Installation Process..... 2
  - 1.4 Safety Information..... 3
  - 1.5 Obtaining Technical Assistance..... 3
  - 1.6 Specifications..... 4
  
- Chapter 2: Preparation..... 6**
  - 2.1 Site Selection..... 6
  - 2.2 Tools and Parts Required for Installation..... 8
  - 2.3 Electrostatic Discharge (ESD) Precautions..... 9
  
- Chapter 3: Rack Mounting the Switch..... 10**
  - 3.1 Rack Mounting the Switch (2RU)..... 10
    - 3.1.1 Two-Post Rack Mount (2RU)..... 10
    - 3.1.2 Four-Post Rack Mount (2RU)..... 11
  
- Chapter 4: Cabling the Switch..... 16**
  - 4.1 Grounding the Switch..... 16
  - 4.2 Grounding Adapter Assembly (2RU)..... 16
  - 4.3 Connecting Power Cables..... 18
    - 4.3.1 AC Power Supplies..... 19
    - 4.3.2 DC Power Supplies..... 19
  - 4.4 Connecting Serial and Management Cables..... 23
  
- Chapter 5: Configuring the Switch..... 25**
  
- Appendix A: Status Indicators..... 27**
  - A.1 Front Indicators..... 27
    - A.1.1 Switch Indicators..... 27
    - A.1.2 Port Indicators..... 28
  - A.2 Rear Status Indicators..... 29
  
- Appendix B: Parts List..... 32**
  - B.1 Accessory Kits..... 32
  - B.2 Cables..... 33
  - B.3 Ground Extender Kit (Optional)..... 33
  
- Appendix C: Front Panel..... 34**

<b>Appendix D: Rear Panel.....</b>	<b>36</b>
<b>Appendix E: Maintenance and Field Replacement.....</b>	<b>38</b>
E.1 Considerations.....	38
E.2 Power Supplies.....	38
E.2.1 Removing a Power Supply.....	38
E.2.2 Installing a Power Supply.....	39
E.3 Fan Modules.....	39
E.3.1 Removing a Fan Module.....	40
E.3.2 Installing a Fan Module.....	40
<b>Appendix F: Regulatory Model Numbers.....</b>	<b>42</b>
<b>Appendix G: Taiwan RoHS Information.....</b>	<b>43</b>

## Overview

---

This guide is intended for properly trained service personnel and technicians who need to install selected Arista Networks Data Center Switches.

This section discusses the following topics:

- [Scope](#)
- [Receiving and Inspecting the Equipment](#)
- [Installation Process](#)
- [Safety Information](#)
- [Obtaining Technical Assistance](#)
- [Specifications](#)

### 1.1 Scope

This guide covers the following devices:

#### **2RU Switches**

DCS-7280R4-32PE

DCS-7280R4K-32PE

DCS-7280R4-32DE

DCS-7280R4K-32DE

DCS-7280R4-64QC-10PE

DCS-7280R4K-64QC-10PE

#### **Important:**



Only qualified personnel should install, service, or replace this equipment.

Seul le personnel qualifié doit installer, service, ou remplacer cet équipement.

### 1.2 Receiving and Inspecting the Equipment

Upon receiving the switch, inspect the shipping boxes and record any external damage. Retain packing materials if you suspect that part of the shipment is damaged; the carrier may need to inspect them.

If the boxes were not damaged in transit, unpack them carefully. Ensure that you do not discard any accessories that may be packaged in the same box as the main unit.

---

Inspect the packing list and confirm that you received all listed items. Compare the packing list with your purchase order. The [Parts List](#) provides a list of components included with the switch.

## 1.3 Installation Process

This section discusses the task required to install and use the switch.

1. Select and prepare the installation site ([Site Selection](#)).
2. Assemble the installation tools ([Tools and Parts Required for Installation](#)).
3. Attach the mounting brackets and install the switch in an equipment rack ([Rack Mounting the Switch](#)).
4. Connect the switch to the power source and network devices ([Cabling the Switch](#)).
5. Configure the switch ([Configuring the Switch](#)).

### Important:

**Class 1 Laser Product:** This product has provisions to install Class 1 laser transceivers which provide optical coupling to the communication network. Once a Class 1 laser product is installed, the equipment is a Class 1 Laser Product. The customer is responsible for selecting and installing the Class 1 laser transceiver and for insuring that the Class 1 AEL (Allowable Emission Limit) per EN/IEC 60825, CSA E60825-1, and Code of Federal Regulations 21 CFR 1040 is not exceeded after the laser transceiver have been installed. Do not install laser products whose class rating is greater than 1. Refer to all safety instructions that accompanied the transceiver prior to installation. Only Class 1 laser devices, certified for use in the country of installation by the cognizant agency are to be utilized in this product.



**Produit Laser de classe 1:** Ce produit a des dispositions pour installer des émetteurs-récepteurs de laser de classe 1 qui offre de couplage au réseau de communication optique. Une fois un produit laser de classe 1 est installé, l'équipement est un produit Laser de classe 1 (Appareil à Laser de Classe 1). Le client est responsable pour sélectionner et installer l'émetteur/récepteur de laser de classe 1 et pour assurer que la classe 1 AEL (limite d'émission admissible) par EN/IEC 6-825, CSA E60825-1, et Code des règlements fédéraux 21 CFR 1040 ne soit pas dépassée après avoir installé l'émetteur/récepteur de laser. Ne pas installer des appareils à laser dont la cote de classe est supérieure à 1. Voir toutes les consignes de sécurité qui ont accompagné l'émetteur-récepteur avant l'installation. Seuls appareils laser de classe 1 certifiés pour une utilisation dans le pays d'installation par l'organisme compétent doivent être utilisées dans ce produit.

### Important:

Ultimate disposal of this product should be handled in accordance with all national laws and regulations.



L'élimination finale de ce produit doit être effectuée conformément à toutes les lois nationales et règlements.

## 1.4 Safety Information

Refer to the Arista Networks document *Safety Information and Translated Safety Warnings* at <https://www.arista.com/en/support/product-documentation>.

## 1.5 Obtaining Technical Assistance

Any customer, partner, reseller, or distributor holding a valid Arista Service Contract can obtain technical support in any of the following ways.

- **Email:** [support@arista.com](mailto:support@arista.com). This is the easiest way to create a new service request.

Include a detailed description of the problem and the output of “show tech-support”.

- **Web:** <https://www.arista.com/en/support>.

A support case may be created through the support portal on our website. You may also download the most current software and documentation, as well as view FAQs, Knowledge Base articles, Security Advisories, and Field Notices.

- **Phone:** +1 866-476-0000 or +1 408-547-5502.

**Note:**



No user serviceable parts inside. Refer all servicing to qualified service personnel.

Aucune pièce réparable par l'utilisateur à l'intérieur. Confiez toute réparation à un technicien qualifié.

## 1.6 Specifications

This guide covers a list of specifications for Arista data center modular switches and components.

**Table 1: Switch Specifications (Dimensions and Weights)**

Switch	Size (W x H x D)	Weight
<i>2RU switches</i>		
DCS-7280R4-32PE	48.3 x 8.8 x 62.9 cm (19 x 3.50 x 24.8 inches)	22.9 kg (50.4 lbs.)
DCS-7280R4K-32PE	48.3 x 8.8 x 62.9 cm (19 x 3.50 x 24.8 inches)	22.9 kg (50.4 lbs.)
DCS-7280R4-32DE	48.3 x 8.8 x 62.9 cm (19 x 3.50 x 24.8 inches)	22.9 kg (50.4 lbs.)
DCS-7280R4K-32DE	48.3 x 8.8 x 62.9 cm (19 x 3.50 x 24.8 inches)	22.9 kg (50.4 lbs.)
DCS-7280R4-64QC-10PE	48.3 x 8.8 x 62.9 cm (19 x 3.50 x 24.8 inches)	22.8 kg (50.2 lbs.)
DCS-7280R4K-64QC-10PE	48.3 x 8.8 x 62.9 cm (19 x 3.50 x 24.8 inches)	22.8 kg (50.2 lbs.)

**Table 2: Switch Specifications (Operational and Storage)**

Switch	Operating <sup>1</sup> Temperature	Storage Temperature	Operating Altitude <sup>1</sup>	Relative Humidity
All	0° to 40°C (32° to 104°F)	-25° to 70°C (-13° to 158°F)	0 to 3,000 meters (0 to 10,000 feet)	5 to 90% (non-condensing)

<sup>1</sup> The use of high power transceivers may require temperature or altitude de-rating.

**Table 3: Switch Specifications (Power Input)**

Power Source	PSU Models	Ratings
<b>Power Input: AC</b>		
	PWR-3211-HV <sup>1</sup>	200 - 277 VAC, 18 A 50/60 Hz
	PWR-2411-AC	200 - 240 VAC, 14 A, 50/60 Hz
<b>Power Input: DC</b>		
	PWR-3211-HV <sup>1</sup>	240 to 380 VDC, 18 A (at 200 VAC)
	PWR-3211-DC	-48 to -60 VDC, 73 A
	PWR-2411-DC	-48 to -60 VDC, 55 A

<sup>1</sup> Check switch datasheets for compatibility with the PWR-3211-HV PSU.



**Note:** Use only the PSU models supported by the switch. Some switches described in this guide could use power supplies that may no longer be available. Contact your local Arista representative for more information.

**Table 4: Switch Specifications (Power Draw)**

Switch	Power Draw (Typical / Maximum)	Supported Power Supply
<b>2RU switches</b>		
DCS-7280R4-32PE	805 W / 1874 W	PWR-3211-HV PWR-3211-DC
DCS-7280R4K-32PE	805 W / 1874 W	PWR-3211-HV PWR-3211-DC
DCS-7280R4-32DE	805 W / 1874 W	PWR-3211-HV PWR-3211-DC
DCS-7280R4K-32DE	805 W / 1874 W	PWR-3211-HV PWR-3211-DC
DCS-7280R4-64QC-10PE	630 W / 1317 W	PWR-2411-AC PWR-2411-DC
DCS-7280R4K-64QC-10PE	630 W / 1317 W	PWR-2411-AC PWR-2411-DC

## Preparation

---

This section discusses the following topics:

- [Site Selection](#)
- [Tools and Parts Required for Installation](#)
- [Electrostatic Discharge \(ESD\) Precautions](#)

### 2.1 Site Selection

The following criteria should be considered when selecting a site to install the switch.

- **Temperature and Ventilation:** For proper ventilation, install the switch where there is ample airflow to the front and back of the switch. The ambient temperature should not go below 0° or exceed 40°C.

**Important:**

To prevent the switch from overheating, do not operate it in an area where the ambient temperature exceeds 40°C (104°F).



Pour empêcher l'interrupteur de surchauffe, ne pas utiliser il dans une zone où la température ambiante est supérieure à 40°C (104°F).



**Note:** When applying labels to any switch, avoid covering ventilation perforations in the front and rear panels. Apply labels only to solid surface areas where there are no perforations. Use the pull-out tag on the front or rear of the switches, when provided, to apply custom labels. For switches that include a plastic tag with the accessory kit, use a single ventilation hole to clip the tag.

- **Airflow Orientation:** The fans and PSUs determine the airflow direction through the switch. The color of the visible handles or labels indicates the airflow direction.



**Note:** The figures shown use representative Arista switches to illustrate airflow directions. Refer to the [Rear Panel](#) to determine the airflow for your switch.

- **Blue Handle:** Air Inlet module. The following figure shows the airflow through the switch with air inlet modules:

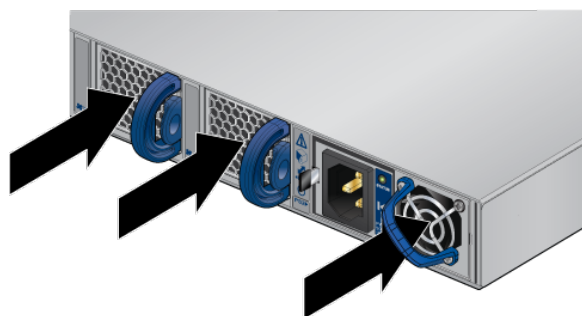

- **Red Handle:** Air Exit module. The following figure shows the airflow through the switch with air exit modules:

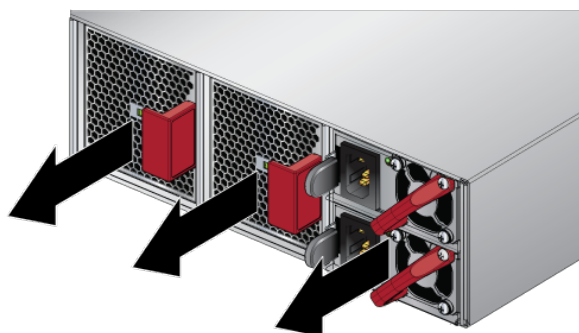

Orient the switch such that the airflow through the switch is from the cooler to the hotter aisle. If the airflow direction is not compatible with the installation site, reorient the fan modules to circulate air in the opposite direction.

The [Rear Panel](#) displays the fan and power supply module locations on the rear panel. Red handles indicate that they are air exit modules. Verify that each module has the same airflow direction. Base the switch orientation on the airflow direction of the modules to assure the air inlet is always oriented toward the cool aisle:

- **Air Exit modules:** orient the rear panel toward the hot aisle.
- **Air Inlet modules:** orient the rear panel toward the cool aisle.

If the airflow direction is not compatible with the installation site, contact your sales representative to obtain modules that circulate air in the opposite direction.

- **Rack Space:** Install the switch in a 19" rack or cabinet. The switches covered by this guide may be 1 RU or 2 RU in height. The accessory kit provides approved mounting brackets for the system. Four-post mounting is recommended for all systems. Where 2-post parts are supplied, they are intended for center-mounting of the device.

When mounting the switch in a partially filled rack, load the rack from bottom to top, with the heaviest equipment at the bottom. Load the switch at the bottom if it is the only item in the rack.

- 
- **Power Requirements:** Power requirements vary by switch and power supply model. [Table 3: Switch Specifications \(Power Input\)](#) and [Table 4: Switch Specifications \(Power Draw\)](#) provide information regarding your specific system.

Two circuits provide redundancy protection. [Cabling the Switch](#) describes power cable requirements.



**Note:** Handle or label color indicates airflow direction.

**Important:**

The power input plug-socket combination must be accessible at all times; it provides the primary method of disconnecting power from the system.



La combinaison de la puissance-prise d'entrée doit être accessible en tout temps ; Il fournit le principal moyen de coupure d'alimentation du système.

- **Other Requirements:** Select a site where liquids or objects cannot fall onto the equipment, and foreign objects are not drawn into the ventilation holes. Verify that these guidelines are met:
  - Clearance areas to the front and rear panels allow for unrestricted cabling.
  - All front and rear panel indicators can be easily read.
  - Power cords can reach from the power outlet to the connector on the rear panel.

**Important:**

All power connections must be removed to de-energize the unit.



Toutes les connexions d'alimentation doivent être enlevées pour hors tension l'appareil.

## 2.2 Tools and Parts Required for Installation

Each switch provides an accessory kit that contains the parts required to install the switch.

In addition to the accessory kit, the following tools and equipment are required to install the switch:

### Four-Post Rack (Tool-less)

No additional equipment required.

### Four-Post Rack (Conventional)

- Screws or rack mounting nuts and bolts.
- Screwdriver

Accessory kit does not include screws for attaching the switch to the equipment rack. When installing the switch into an equipment rack with unthreaded post holes, nuts are also required to secure the switch to the rack posts.

## 2.3 Electrostatic Discharge (ESD) Precautions

Observe these guidelines to avoid ESD damage when installing or servicing the switch.

- Assemble or disassemble equipment only in a static-free work area.
- Use a conductive work surface (such as an anti-static mat) to dissipate static charge.
- Wear a conductive wrist strap to dissipate static charge accumulation.
- Minimize handling of assemblies and components.
- Keep replacement parts in their original static-free packaging.
- Remove all plastic, foam, vinyl, paper, and other static-generating materials from the work area.
- Use tools that do not create ESD.

## Rack Mounting the Switch

---

### Rack Mounting the Switch (2RU)

This section discusses the following topics:

#### [Rack Mounting the Switch \(2RU\)](#)



**Note:** Four-post rack mount is recommended for all switches. Use the rack-mount parts included with your switch for mounting. Rails from different kit SKUs may look similar, but could be incompatible, leading to the inability to properly mount or remove a switch from the rack.

After completing the instructions for your rack type, proceed to [Cabling the Switch](#).

### 3.1 Rack Mounting the Switch (2RU)

This section discusses the following topics:

- [Two-Post Rack Mount \(2RU\)](#)
- [Four-Post Rack Mount \(2RU\)](#)

In two-post and four-post racks for 2RU switches.

#### **Important:**

The rack mounting procedure is identical for all switches covered by this guide. Illustrations in this chapter depict the mounting of a DCS-7050SX-128 switch.



Les procédure de montage du bâti est identique pour tous les commutateurs visés par ce guide. Illustrations dans ce chapitre montrent le montage d'un interrupteur de DCS-7050SX-128.

After completing the instructions for your rack type, proceed to [Cabling the Switch](#).

#### 3.1.1 Two-Post Rack Mount (2RU)

The 2RU switches covered in this guide do not support two-post rack mounting. The accessory kit contains only the four-post RMK components. Contact your local Arista Networks representative for further information if you require two-post rack mounting.

### 3.1.2 Four-Post Rack Mount (2RU)

The switch is mounted onto a four-post rack by assembling two rails onto the rear posts, sliding the switch onto the rails, and then securing the switch to the front posts.

The installation kit provides two bracket-rail assemblies. The following four-post mounting parts are extracted from each assembly:

- Switch brackets
- Rail brackets

Each chassis side has attachment pins that align with bracket holes; the number of pins varies by switch model. Pin orientation is symmetric and equidistant, supporting bracket placement where the flange is either flush with the front and rear panels, or not flush with the panels. Each bracket hole includes a key-opening for placing the bracket flush with the chassis and then locking it into place.

**Important:**

Attachment pins must engage all six bracket holes.



Goupilles de fixation doivent s'engager tous les trous de support six.

### 3.1.2.1 Extracting the Brackets and the Rails

The following figure displays a bracket-rail assembly and the component pieces (bracket and rail) that are extracted from the assembly kit. Each assembly must be separated into its component pieces before mounting the switch into a four-post rack. The two assemblies supplied with the switch are identical.

**Figure 3-1: Accessory Kit Components**

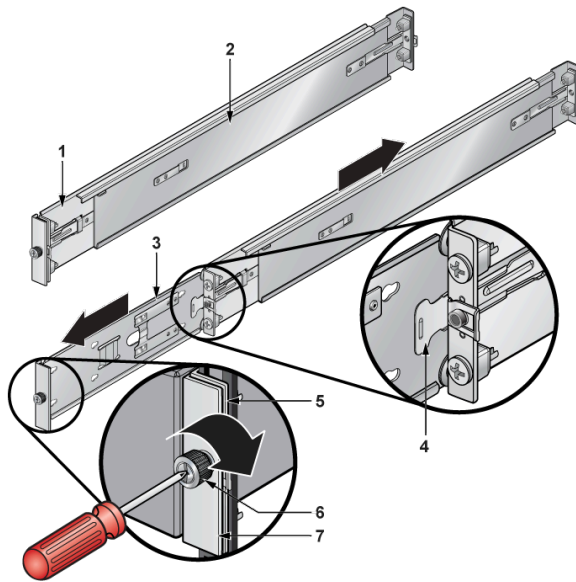

- |  |                     |                       |
|--|---------------------|-----------------------|
| 1 Rail bracket (front)                     | 4 Locking clip      | 7 Switch mounting ear |
| 2 Rail bracket (rear)                      | 5 Rail mounting ear |                       |
| 3 Switch bracket (for attaching to switch) | 6 Thumb screw       |                       |

This procedure separates a bracket-rail assembly into its component pieces.

1. Grip the rail with one hand.
2. Pull the bracket flange away from the rail flange with your other hand until the bracket clip catches on the rail.  
If the bracket flange resists initially, verify the thumb screw on the bracket flange is not attached to the rail flange.
3. While pressing the locking clip on the bracket, resume pulling the bracket from the rail until the separation is complete.
4. Repeat the procedure for the other assembly.

### 3.1.2.2 Attaching Mounting Brackets to the Chassis

The following figure displays the switch bracket alignment for mounting the switch into a four-post rack.

**Figure 3-2: Front Bracket Alignment**

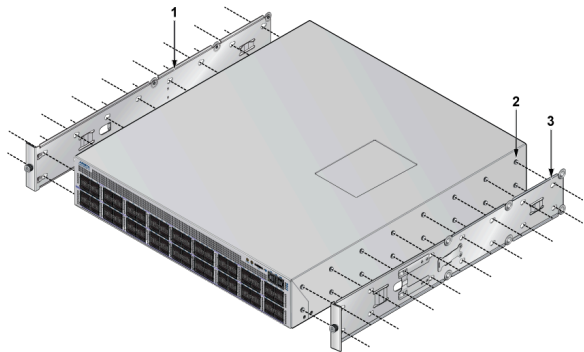

1 Switch bracket

2 Attach point

3 Matching attachment hole

This procedure attaches mounting brackets to the switch chassis as depicted by the following figure.

1. Align the mounting brackets with the attachment pins.
2. Place the bracket flush on the chassis with attachment pins protruding through key-openings.
3. Slide the bracket toward the front flange until the rail locks with an audible click.

**Figure 3-3: Attaching the Mounting Brackets to the Switch Chassis**

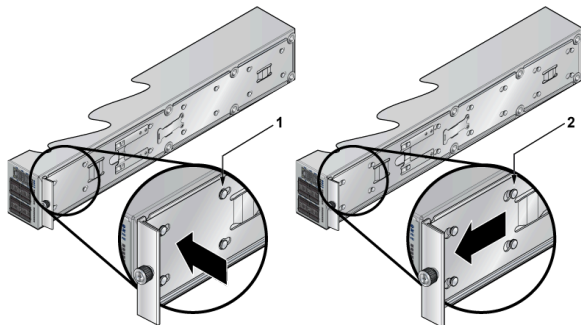

1 Aligned rail

2 Seated rail

To remove the mounting bracket from the chassis, lift the front edge of the mounting bracket clip with a flathead screwdriver and slide the bracket away from the front flange (opposite from the installation direction).

### 3.1.2.3 Expanding the Rails

The rail is a two-piece mechanism. The rail length is adjusted by sliding the rail-rod inside the rail-slide. The rail clip prevent extension of the rail beyond the maximum supported distance between front and rear rack posts. When the rail is contracted, the rail clip is closest to the slide end.

The rail is initially contracted and must be expanded to attach to the rack. This procedure expands the rails from their contracted state:

1. Grip the slide end with your left hand and the rod end with your right hand.
2. Pull the ends apart until the rail-clip makes an audible click.

### 3.1.2.4 Assembling the Rails onto the Equipment Rack

A rail connects a front post to a rear post. Each end has two rack plugs. Rails are installed into a rack by inserting the plugs into the rack slots. To install rails into posts with threaded or rounded holes, remove all plugs on both sides of the rails, then install the rails with bolts that fit the rack. This procedure attaches the rails to a four-post rack:

1. Attach rail to the right rear rack post by inserting rod-end rack plugs into post slots. The slide assembly must be inside the right posts, relative to the left rack posts ([Figure 3-4: Attaching the Rails](#)).  
If the rack plugs were previously removed, use bolts to attach the rail to the rack.
2. Attach the slide end of the rail to the front post by extending the rail end past the post, then contracting the rail while guiding the rack plugs into the post.
3. Repeat Steps 1 through 2 for the left posts. Ensure the rails are on the same horizontal level.

**Figure 3-4: Attaching the Rails**

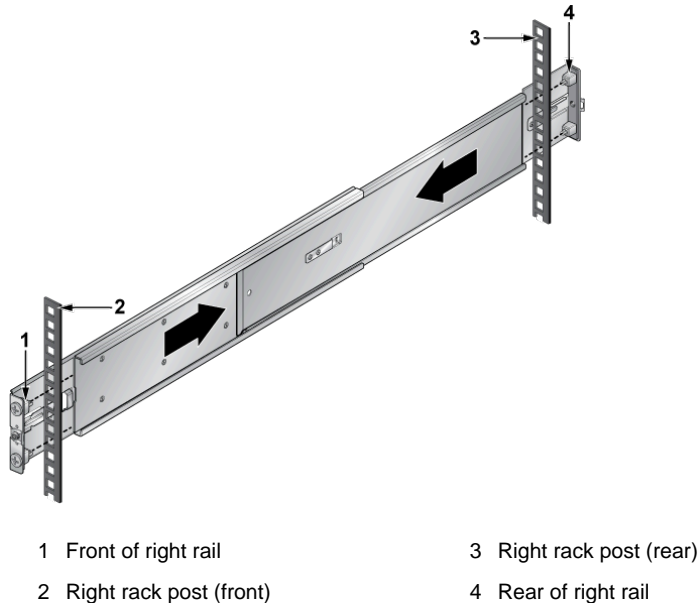

- |                           |                          |
|---------------------------|--------------------------|
| 1 Front of right rail     | 3 Right rack post (rear) |
| 2 Right rack post (front) | 4 Rear of right rail     |

### 3.1.2.5 Attaching the Switch to the Rack

After the rails are installed, the switch slides on the rails into the rack. Each bracket includes a thumb screw that attaches the switch to the rail.



**Note:** Illustrations shown could be different based on your accessory kit.

1. Lift the switch into the rack and insert the mounting brackets into the slide rails.

- Slide the switch on the rails, toward the rear posts, until the mounting bracket flanges are flush with the rail flanges attached to the rack posts.

**Figure 3-5: Inserting the Switch onto the Rails**

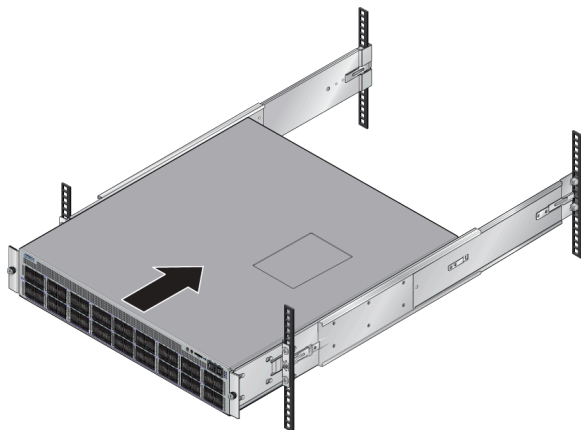

- Attach the bracket flanges to the rack post using the quick-release thumb screws supplied with the brackets. Hand-tighten the thumb screws or use a Phillips #2 screwdriver.



**Note:** Do not exceed a maximum torque of 20in-lb or use powered impact drivers to secure the thumb screws.

**Figure 3-6: Attaching the Switch to the Rack Posts**

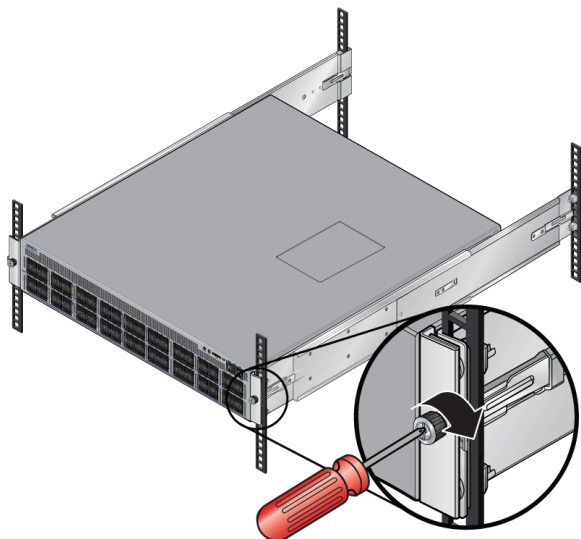

After completing the four-post rack mount, proceed to [Cabling the Switch](#).

## Cabling the Switch

---

This section discusses the following topics:

- [Grounding the Switch](#)
- [Connecting Power Cables](#)
  - [AC Power Supplies](#)
  - [DC Power Supplies](#)
- [Connecting Serial and Management Cables](#)



**Note:** Arista fixed switches take approximately 5 to 10 minutes to boot completely.

### 4.1 Grounding the Switch

After mounting the switch into the rack, connect the switch to the data center ground.



**Note:** NEBS-compliant deployments require chassis grounding. Use the grounding point(s) on the switch directly or with the appropriate ground adapter kit to ground the chassis. Grounding on the hot-swappable power supplies cannot ensure continuous grounding to the chassis when a power supply is removed.

For the 2RU switches, the grounding location is at the rear panel of the switches or on the side using the KIT-GND-EXT-2RU grounding kit.

#### **Important:**

Grounding wires and grounding lugs (M4 x 0.7) are not supplied. Wire size should meet local and national installation requirements. Commercially available 6 AWG wire is recommended for installations in the US.



À la terre et de mise à la terre fils cosses (M4 x 0.7) ne sont pas fournis. Calibre des fils doit satisfaire des exigences de l'installation locale et nationale. Disponible dans le commerce 6 fils AWG est recommandé pour les installations aux États-Unis.

## 4.2 Grounding Adapter Assembly (2RU)

The following steps attach a grounding assembly KIT-GND-EXT-2RU to the side of the supported 2RU chassis before mounting it into the rack.

Identify the location for attaching the adapter or the lug. As shown in the following example, the attachment point is on the side of the chassis for the switches that support the KIT-GND-EXT-2RU grounding kit. The grounding location is on the back for those supporting direct attach.

**Table 5: Grounding Kit Adapter Support (2RU)**

Switch	Grounding Kit Adapter
DCS-7280R4-32PE	KIT-GND-EXT-2RU
DCS-7280R4K-32PE	KIT-GND-EXT-2RU
DCS-7280R4-32DE	KIT-GND-EXT-2RU
DCS-7280R4K-32DE	KIT-GND-EXT-2RU
DCS-7280R4-64QC-10PE	KIT-GND-EXT-2RU
DCS-7280R4K-64QC-10PE	KIT-GND-EXT-2RU

The following figure shows the exploded and assembled views of using the KIT-GND-EXT-2RU grounding kit.

**Figure 4-1: Earth Grounding Adapter for Side Attach**

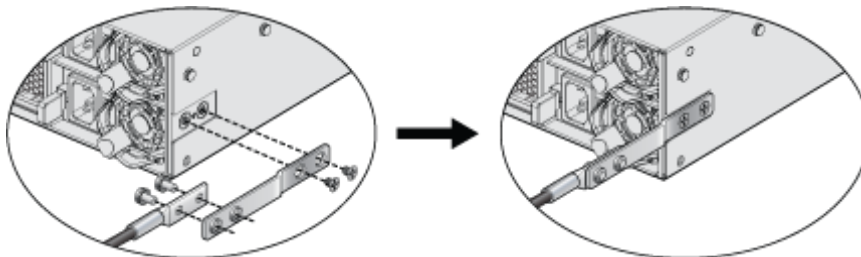

1. Identify all the components to be assembled:
  - 1x Grounding adapter
  - 1x Grounding bracket
    - 2x Flat-head screws (Phillips, M4 x 5.00 long, stainless steel)
    - 2x Hex nuts (#10-32, Serrated Flange, stainless steel)
  - 1x Grounding lug (Copper, 2-hole, 6 AWG, straight barrel)
2. Insert the grounding adapter through the holes in the grounding bracket.
3. Insert the ground lug onto the grounding adapter studs and fasten using the hex nuts to form the grounding assembly.
4. With the chassis on a flat surface, attach the grounding assembly to the chassis using the flat head screws.

---

## 4.3 Connecting Power Cables

You must use an approved power cord that is compliant with local and national electrical codes or order one from Arista for use with the switch. Some power cords are shipped with each switch as part of the accessory kit.

**Important:**

Installation of this equipment must comply with local and national electrical codes. If necessary, consult with the appropriate regulatory agencies and inspection authorities to ensure compliance.



Installation de cet équipement doit être conformes aux codes électriques locaux et nationaux. Si nécessaire, consulter les organismes de réglementation appropriés et des autorités de contrôle pour assurer la conformité.

The switch operates with two installed power supplies. At least one power supply must connect to a power source. Two circuits provide redundancy protection. [Rear Panel](#) displays the location of the power supplies on the rear panel of the switch.

**Important:**

Read all installation instructions before connecting the system to the power source.



Lire toutes les instructions d'installation avant de brancher le système à la source d'alimentation.

- **Non-Redundant Configuration:** Connect power to either of the two power supplies.
- **Redundant Power Supply Configuration:** Connect power to both power supplies.
- **Power down the Switch:** Remove all power cords and wires from the power supplies.

**Important:**

This equipment must be grounded. Never defeat the ground conductor.



Cet équipement doit être mis à la terre. Ne jamais modifier le conducteur de terre.

**Important:**

This unit requires overcurrent protection.



Cet appareil requiert une protection contre les surintensités.

### 4.3.1 AC Power Supplies

The following AC power supplies are supported.

PWR-2411-AC

PWR-3211-HV

[Figure 4-2: AC Power Supply Example](#) displays an AC power supply, including the power socket and the release. The AC power supply connects to a circuit that provides the required power, as specified by [Table 4: Switch Specifications \(Power Draw\)](#).



**Note:** Several PSUs support both forward and reverse airflow directions.

**Figure 4-2: AC Power Supply Example**

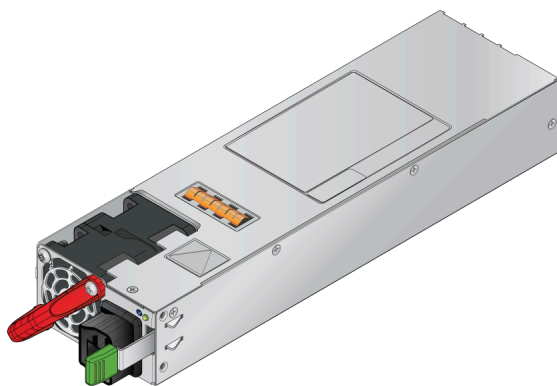

The accessory kit provides power cables for some switches.

### 4.3.2 DC Power Supplies

The following DC power supplies are supported.



**Note:** Several PSUs support both forward and reverse airflow directions.

PWR-3211-HV

PWR-3211-DC

PWR-2411-DC

The following image displays examples of DC power supplies.

**Figure 4-3: DC Power Supply Example**

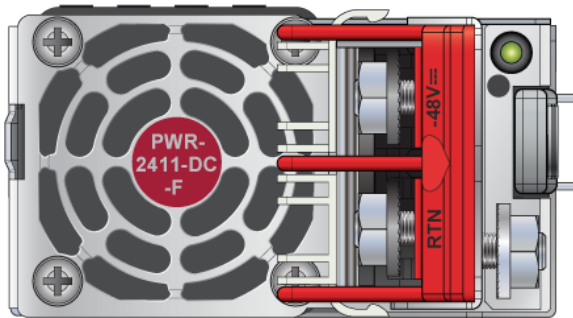

**Important:**

A disconnect device must be provided as part of the installation.



Un dispositif de sectionnement doit être fourni dans le cadre de l'installation.

**Important:**

Ensure power is removed from DC circuits before performing any installation actions. Locate the disconnect device, circuit breakers or fuses on DC power lines servicing the circuits. Turn off the power line circuits or remove the fuses.



Pouvoir assurer qu'il est retiré de circuits DC avant d'effectuer des actions d'installation . Localiser les disjoncteurs ou des fusibles sur les lignes de courant continu desservant les circuits. Coupez les circuits de lignes d'alimentation ou retirer les fusibles.

**Important:**

Wire size must comply with local and national requirements and electrical codes. Use only copper wire.



Le calibre du fil doit être conforme aux exigences locales et nationales et les codes électriques. Utiliser du fil de cuivre.

**Important:**

Apply ground connection to the switch first during installation and remove last when removing power.



Appliquer connexion à la terre à l'interrupteur premier lors de l'installation et de supprimer la dernière alimentation lors du débranchement.

### 4.3.2.1 Wire and Lug Preparation

Before performing any installation actions, ensure power is removed from DC circuits by turning off the power line servicing the circuits. Prepare the stranded wiring before you begin a DC power installation.



**Note:** Stranded copper wiring is required and should meet local and national installation requirements. Wires and grounding lugs are not supplied.

1. Attach an ESD grounding strap.
2. Prepare the stranded copper wiring for the power supply to be used. [Table 4: Switch Specifications \(Power Draw\)](#) provides wiring, lug, and tightening torque information for the power supplies covered in this guide.

**Table 6: Wiring, Lug, and Tightening Torques for DC PSUs**

PSU	Wire Size <sup>(1)</sup>		Lug Type <sup>(2)</sup>	Tightening Torque	
	(AWG)	(mm <sup>2</sup> )		N•m	in.•lbs.
PWR-3211-DC	2 - 4	35.0 - 25.0		2.7	24
PWR-2411-DC	2 - 4	35.0 - 25.0		2.7	24

1. Unless otherwise noted, wire size applies to -48V, Battery return, and Protective earth wires.
2. Unless otherwise noted, twin #10 studs spaced for dual-hole lug with 5/8" hole spacing.
3. Strip the wires to the appropriate length for the lugs to be used.
4. Use agency-approved compression (pressure) lugs for wiring terminations.
5. Slip on heat-shrink tubing on the wire ends before assembling the lugs onto the wire.
6. Crimp the lugs with the proper tool, and ensure that the tubing extends over the barrel of the lugs and the insulation on the wires ([Lug Preparation](#)).

7. Shrink the tubing with a heat gun.

**Figure 4-4: Lug Preparation**

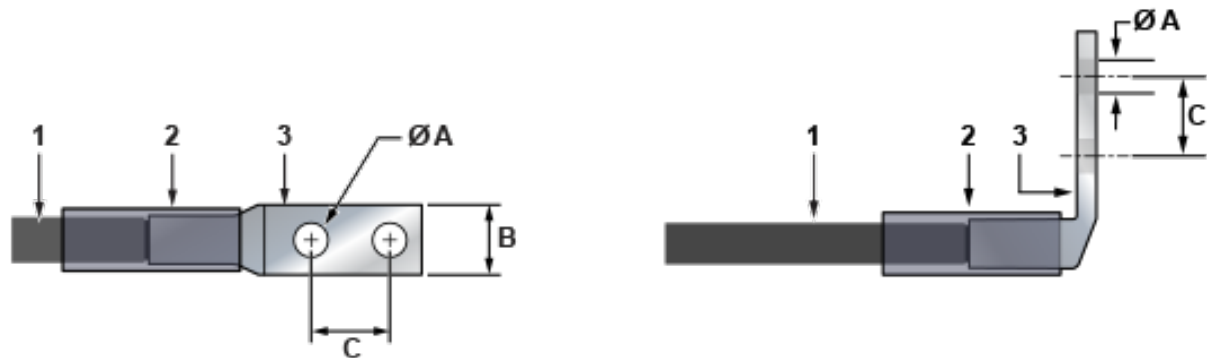

- 1 Insulated wire
- 2 Heat-shrink tubing

- 3 Lug
- A 1/4"

- B 1/2"  
C 5/8"



**Note:** Dimension B is the width of the lug (not visible on the right angle lug).

#### 4.3.2.2 Connecting a DC Power Supply to Power Source

Figure 4-5: DC PSU Connection Example displays an example of connecting a PSU. To connect a DC power supply to a power source, perform the following:

1. Prepare the stranded wiring ([Wire and Lug Preparation](#)).
2. Attach the appropriate lugs to the source DC wires.
3. Connect the DC-input wires to the appropriate terminals using the specified torque ([Table 4: Switch Specifications \(Power Draw\)](#)) in the following order.



**Note:** Remove terminal covers as needed.

- a. Ground wire to the Protective Earth (PE  $\oplus$ ) terminal.
  - b. Negative source DC cable to the negative (- / -48V) terminal.
  - c. Positive (+) source DC cable to the positive (+ / Rtn) terminal.
4. Replace the terminal covers as required.



**Note:** The ground terminal is on the opposite side from the two terminals shown, and is not visible in the following illustration.

**Figure 4-5: DC PSU Connection Example**

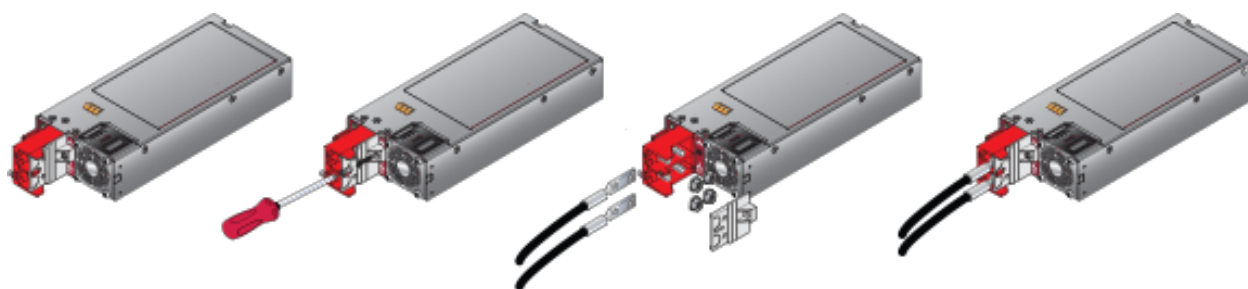

## 4.4 Connecting Serial and Management Cables

The accessory kit includes the following cables:

- RJ-45 to DB-9 serial adapter cable.
- RJ-45 Ethernet cable.

[Table 7: RJ-45 to DB-9 Connections](#) lists the pin connections of the RJ-45 to DB-9 adapter cable.

**Table 7: RJ-45 to DB-9 Connections**

RJ-45		DB-9		RJ-45		DB-9	
RTS	1	8	CTS	GND	5	5	GND
DTR	2	6	DSR	RXD	6	3	TXD
TXD	3	2	RXD	DSR	7	4	DTR
GND	4	5	GND	CTS	8	7	RTS



**Note:** RJ-45 to DB-9 connections: For models with a console management port on the rear panel, RJ-45 pin 1 (RTS) is connected to RJ-45 pin 8 (CTS); RJ-45 pin 2 (DTR) and RJ-45 pin 7 (DSR) are not electrically connected to any signal.

For most models, the front panel contains the console, management, and USB ports. These ports could also be located on rear panel for some switches.

**Figure 4-6: Management Ports**

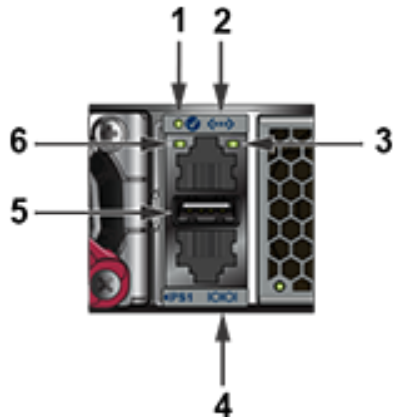

- |                            |                       |                   |
|----------------------------|-----------------------|-------------------|
| 1 System status LED        | 3 Activity status LED | 5 USB port        |
| 2 Ethernet management port | 4 Console serial port | 6 Link status LED |

Connect the front or rear panel ports as follows:

- **Console (Serial) Port:** Connect to a PC with the RJ-45 to DB-9 serial adapter cable. The switch uses the following default settings:
  - 9600 baud
  - No flow control
  - 1 stop bit
  - No parity bits
  - 8 data bits
- **Ethernet Management Port:** Connect to a 10/100/1000 management network with an RJ-45 Ethernet cable.
- **USB Port:** The USB port may be used for software or configuration updates.

**CAUTION:**

Excessive bending can damage interface cables, especially optical cables.



Flexion excessive peut endommager les câbles d'interface, notamment des câbles optiques.

## Configuring the Switch

---

Arista switches ship from the factory in Zero Touch Provisioning (ZTP) mode. ZTP configures the switch without user intervention by downloading a startup configuration file or a boot script from a location specified by a DHCP server.

To manually configure a switch, ZTP is bypassed. The initial configuration provides one username (admin) accessible only through the console port because it has no password.

When bypassing ZTP, initial switch access requires logging in as admin, with no password, through the console port. Then you can configure an admin password and other password protected usernames.

This manual configuration procedure cancels ZTP mode, logs into the switch, assigns a password to admin, assigns an IP address to the management port, and defines a default route to a network gateway.

As the switch boots without a startup-config file, it displays the following through the console:

```
The device is in Zero Touch Provisioning mode and is attempting to
download the startup-config from a remote system. The device will not
be fully functional until either a valid startup-config is downloaded
from a remote system or Zero Touch Provisioning is cancelled. To cancel
Zero Touch Provisioning, login as admin and type 'zerotouch cancel'
at the CLI.
```

```
localhost login:
```

1. Provide power to the switch ([Cabling the Switch](#)).
2. Connect the console port to a PC ([Connecting Serial and Management Cables](#)).
3. Log into the switch by typing **admin** at the login prompt.

```
localhost login: admin
```

4. Cancel ZTP mode by typing **zerotouch cancel**.



**Important:** This step initiates a switch reboot.

```
localhost> zerotouch cancel
```

5. After the switch boots, log in to the switch again by typing **admin** at the login prompt.

```
Arista EOS
localhost login: admin
Last login: Fri Mar 15 13:17:13 on console
```

6. Enter global configuration mode.

```
localhost> enable
localhost# config
```

7. Assign a password to the admin username with the `username secret` command.

```
localhost(config)# username admin secret pxql23
```

8. Configure a default route to the network gateway.

```
localhost(config)# ip route 0.0.0.0/0 192.0.2.1
```

9. Assign an IP address (**192.0.2.8/24** in this example) to an Ethernet management port.

```
localhost(config)# interface management 1
localhost(config-if-Ma1/1)# ip address 192.0.2.8/24
```

10. Save the configuration by typing `write memory` or `copy running-config startup-config`.

```
localhost# copy running-config startup-config
```

11. When the management port IP address is configured, use this command to access the switch from a host, using the address configured in **Step 9**.

```
ssh admin@192.0.2.8
```

Refer to the *Arista Networks User Manual* for complete switch configuration information.

## Status Indicators

This section discusses the following topics:

- [Front Indicators](#)
  - [Switch Indicators](#)
  - [Port Indicators](#)
- [Rear Status Indicators](#)

### A.1 Front Indicators

Reviews the Switch and Port Indicators of the device.

#### A.1.1 Switch Indicators

Front panel LEDs are located on the chassis to display system, fan, Supervisor, and power supply status.

The following figure shows an example of a representative switch with the status LEDs and ports called out.

**Figure A-1: System Status Indicators**

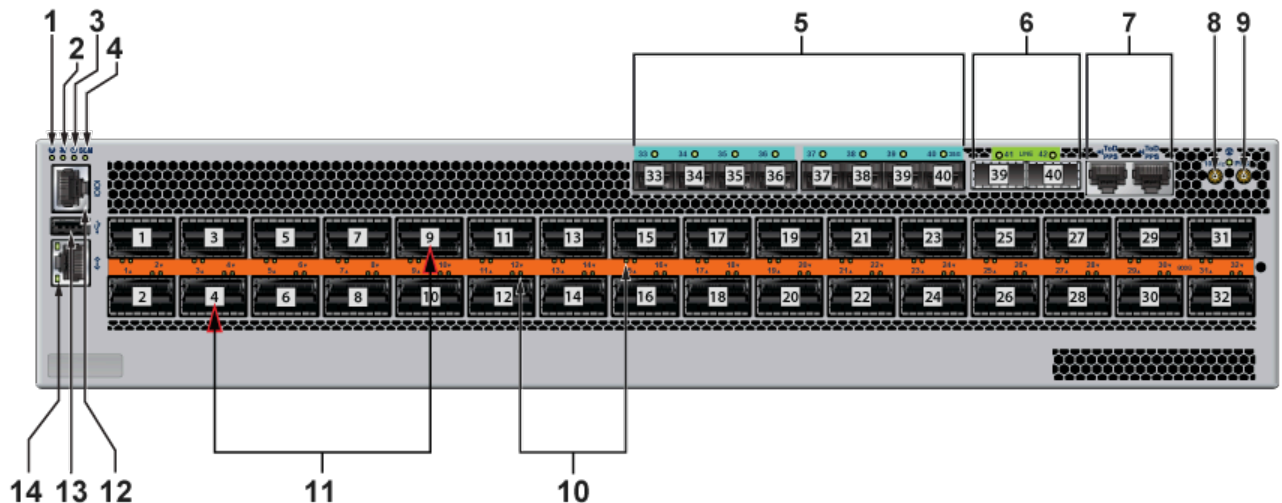

- |                              |                          |                             |
|------------------------------|--------------------------|-----------------------------|
| 1 System status LED          | 7 ToD connectors         | 13 USB port                 |
| 2 Fan status LED             | 8 E-Sync clock connector | 14 Ethernet management port |
| 3 Power supply status LED    | 9 E-Sync clock connector |                             |
| 4 Supervisor card status LED | 10 Port status LEDs      |                             |
| 5 25G SFP ports              | 11 Port numbers          |                             |
| 6 Line system ports (QSFP)   | 12 Console port (serial) |                             |

**Table 8: Switch Indicators LED States (Front)**

LED Name	LED State	Device Status
System Status LED	Blinking Green	System is powering up.
	Green	Normal operations. Due to power supply and fan redundancy, this LED will remain green if a single fan or power supply is missing or in a failed state.
	Blue	The beacon (locator) function is active.
	Amber	Two or more fans (any combination of fan modules or PSU fans) are disconnected or malfunctioning. The switch will automatically execute a “graceful shutdown” shortly.
Fan Status LED	Green	All fan and power modules are operating normally.
	Amber	Single fan module is removed or malfunctioning. It is also amber when a PSU is completely removed or has a stuck fan rotor.
	Red	Two or more fans (any combination of fan modules or PSU fans) are disconnected or malfunctioning. The switch will automatically execute a “graceful shutdown” shortly.
PSU Status LED	Green	PSU is functioning and fully operational. AC is present, Aux output is ON, and Main output is ON.
	Off	PSU has been removed or is not operating properly due to the AC cord being unplugged, its fan rotor being stuck, or an internal fault.
SCM Status LED		

## A.1.2 Port Indicators

Port LEDs, located in the vicinity of their corresponding ports, provide link and operational status. The following figure displays the Port LED location on the DCS-7050QX-32S switch.

**Figure A-2: Port LEDs**

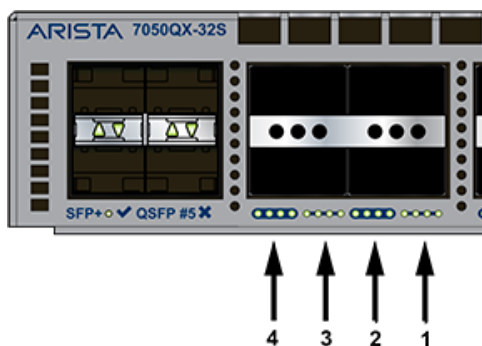

- 1 Port 4 LEDs
- 2 Port 3 LEDs
- 3 Port 2 LEDs
- 4 Port 1 LEDs

[Table 9: Port LED States \(Front\)](#) provides status conditions that correspond to port LED states. Port LED behavior for QSFP+ and SFP+ ports is consistent.

**Table 9: Port LED States (Front)**

LED State	Status
Off	Port link is down.
Green	Port link is up.
Yellow	Port is software disabled.
Flashing Yellow	Port failed diagnostics.

## A.2 Rear Status Indicators

Fan and power supply modules are accessed from the rear panel.

Each fan and power supply module contains an LED that reports the module's status.

Fan Status LEDs are on the fan modules, as displayed in [Figure A-3: Fan Status LED](#).

**Figure A-3: Fan Status LED**

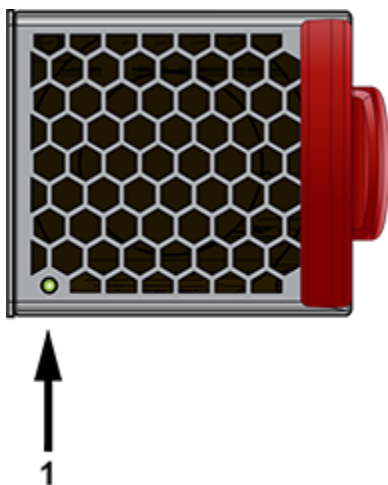

- 1 Fan module status LED

[Table 10: Fan Status LED States \(Rear\)](#) provides status conditions that correspond to fan status LED states.

**Table 10: Fan Status LED States (Rear)**

LED State	Status
Off	The fan module is not detected. If it is inserted, it may not be seated properly.
Green	The fan is operating normally. This LED state is exclusive to its fan module, and independent of the states of its neighboring fans and power supplies.
Red	The fan has failed.

The AC Power Supply Status LEDs are on the power supply modules, as displayed in [Figure A-4: AC Power Supply Status LED Example](#).

**Figure A-4: AC Power Supply Status LED Example**

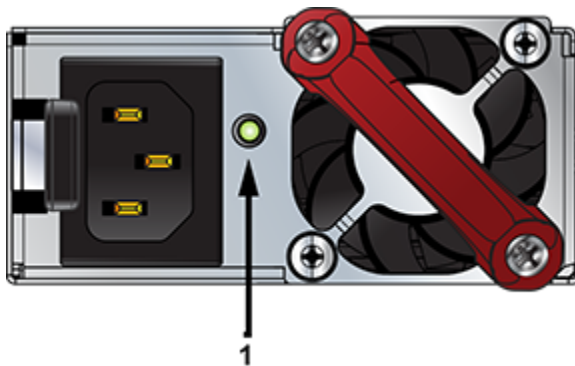

1 Power supply status LED

[Table 11: AC Power Supply Status LED States \(Rear\)](#) provides status conditions that correspond to the AC power supply status LED states.

**Table 11: AC Power Supply Status LED States (Rear)**

Power Supply State	PWR-2411-AC	PWR-3211-HV
Input power present Normal operation	Green	Green
Input power present Power Supply fault	Yellow	Yellow
No Input power Supply installed in chassis	Off	Off
Input power present Supply not installed in chassis	Green	Green

The DC Power Supply Status LEDs are on the power supply modules, as displayed in [Figure A-5: DC Power Supply Status LED](#).

**Figure A-5: DC Power Supply Status LED**

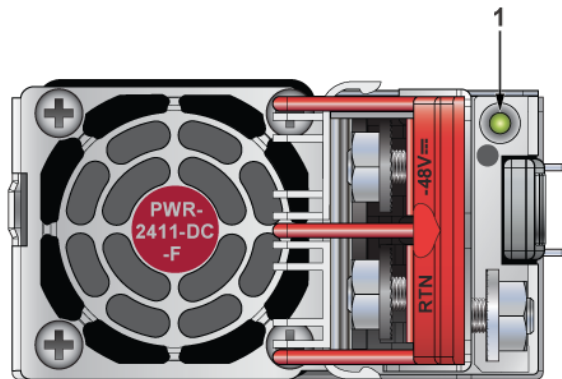

1 Power supply status LED

[Table 12: DC Power Supply Status LED States \(Rear\)](#) provides status conditions that correspond to the DC power supply status LED states.

**Table 12: DC Power Supply Status LED States (Rear)**

Power Supply State	PWR-3211-DC	PWR-2411-DC
Input power present Normal operation	Green	Green
Input power present Power Supply fault	Blinking Yellow	Blinking Yellow
No Input power Supply installed in chassis	Off	Off
Input power present Supply not installed in chassis	Blinking Yellow	Blinking Yellow

 **Note:** You can narrow down the error condition by logging in to the switch to view the specific device state. Refer to the *Arista User Manual's Switch Environment Control* chapter, under the topic *Viewing Environment Status*, for further information on the `show environment` commands.

## Parts List

This section lists the installation parts contained in the switch accessory kit.

Each switch provides an accessory kit that contains parts that are required to install the switch. Four-post rack mount is recommended for all switches. Use the rack-mount parts included with your switch for mounting. Rails from different kit SKUs may look similar but could be incompatible for use with extension kits for longer switches. Depending on the PSU, C13/14, C19/20 or SAF-D type power cables are included in the accessory kit.



**Note:** Use only the components shipped with the switch or compatible replacement parts.

The following topics are covered in this section:

- [Accessory Kits](#)
- [Cables](#)
- [Ground Extender Kit \(Optional\)](#)

### B.1 Accessory Kits

This section describes the components included with the accessory kits available with the switches. Not all kits are shipped with all switches. Use only the parts shipped with the switch or optional, compatible kits. Do not mix parts from incompatible kits such as KIT-7001/2 and KIT-7101/2.

#### KIT-7203

The kit supports rack depths of twenty-two to thirty-two inches for four-post rack mounting of 2-4RU switches.

Assembly Part Number	Description	Quantity
	Four-post brackets	2
	SAF-D GRID - IEC-320/C20, 16A, 250V Cable, 2 meter	2
	RJ45 Patch Panel Cable, 2 meter	1
	RJ45 to DB9 Adapter Cable, 2 meter	1
	Identity tag	1
ASY-06132	Rack ear with captive thumb screw	2
ASY-03765	Front rack shelf with guide block	2
ASY-03767	Rear rack shelf with guide block	2

## B.2 Cables

Lists the cables required for the installation of the switches.

 **Note:** Use only the power cables shipped with your switch.

Quantity	Description
2	Power cables: SAF-D GRID - IEC-320/C20, 16A, 250V Cable, 2 meter
2	Power cables: IEC-320/C19-C20, 16 A, 250 V, 2 m
1	RJ-45 Patch Panel Cable
1	RJ-45 to DB9 Adapter Cable

**Warning:**  
All provided power cables are for use only with Arista products.

 **警告**  
すべての電源コードは提供する製品で使用するためだけを目的としている。  
電源コードの他の製品での使用の禁止  
Aristaが提供するすべての電源コードは、Aristaの製品でのみ使用してください。

## B.3 Ground Extender Kit (Optional)

Lists the cables required for the installation of the device.

SKU	Description
KIT-GND-EXT-2RU <sup>1</sup>	Ground extender kit for NEBS compliance

1. Compatible with specific devices.

## Front Panel

This section displays the front panel of all switches covered by this guide.



**Note:** All devices are designed to fit into a 19" rack. The appearance may be different than those shown based on PSU and fan modules used.

**Figure C-1: DCS-7280R4-32PE, DCS-7280R4K-32PE, DCS-7280R4-32DE and DCS-7280R4K-32DE**

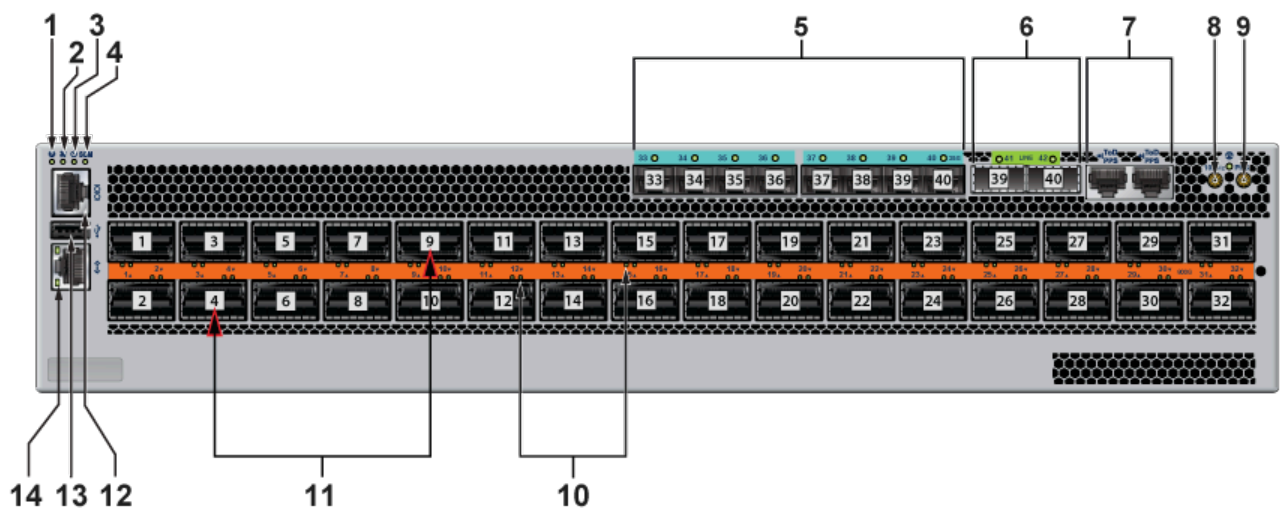

- |                              |                          |                             |
|------------------------------|--------------------------|-----------------------------|
| 1 System status LED          | 7 ToD connectors         | 13 USB port                 |
| 2 Fan status LED             | 8 E-Sync clock connector | 14 Ethernet management port |
| 3 Power supply status LED    | 9 E-Sync clock connector |                             |
| 4 Supervisor card status LED | 10 Port status LEDs      |                             |
| 5 25G SFP ports              | 11 Port numbers          |                             |
| 6 Line system ports (QSFP)   | 12 Console port (serial) |                             |

Figure C-2: DCS-7280R4-64QC-10PE and DCS-7280R4K-64QC-10PE

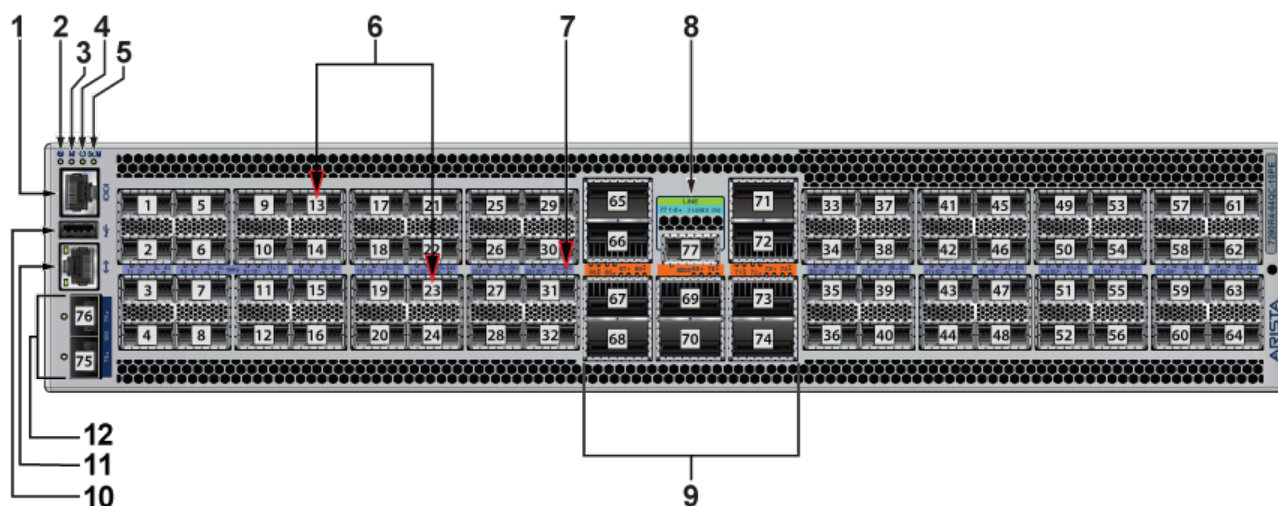

- |                           |                                 |                             |
|---------------------------|---------------------------------|-----------------------------|
| 1 Console port (serial)   | 5 Supervisor card status LED    | 9 800G ports                |
| 2 System status LED       | 6 Port numbers                  | 10 USB port                 |
| 3 Fan status LED          | 7 Port status LED               | 11 Ethernet management port |
| 4 Power supply status LED | 8 Line system ports (SFP, QSFP) | 12 10G ports                |

## Rear Panel

All switches covered by this guide use one of the rear panels shown below. Depending on the installed power supply module, the appearance could be different from that shown. Some of the PSUs have a velcro strap for cable management.



**Note:** All devices are designed to fit into a 19" rack. The appearance may be different than those shown based on PSU and fan modules used.



**Note:** Handle or bezel color indicates airflow direction.

Figure D-1: Rear Panel (2RU)

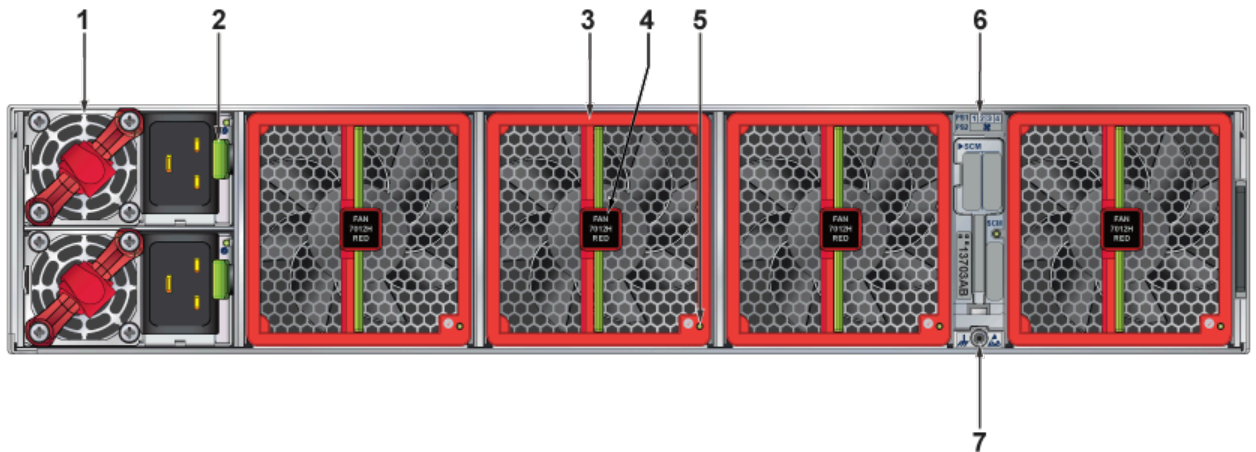

- 1 Power supply module 1
- 2 Power supply release
- 3 Fan module 2

- 4 Fan module release
- 5 Fan module status LED
- 6 Supervisor access

- 7 ESD attach point

Figure D-2: Rear Panel (2RU)

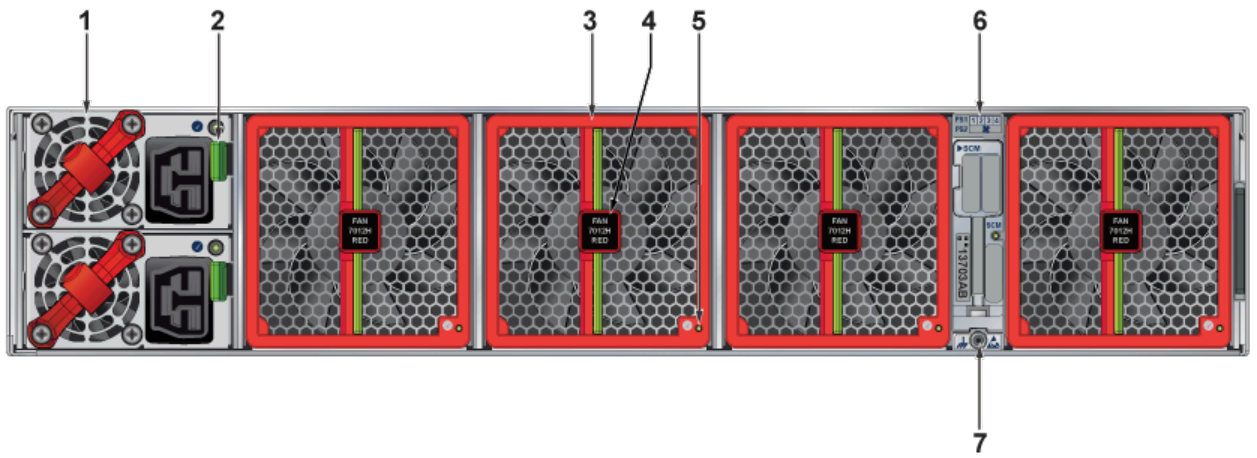

- 1 Power supply module 1
- 2 Power supply release
- 3 Fan module 2

- 4 Fan module release
- 5 Fan module status LED
- 6 Supervisor access

- 7 ESD attach point

## Maintenance and Field Replacement

---

This section discusses the following topics:

- [Considerations](#)
- [Power Supplies](#)
  - [Removing a Power Supply](#)
  - [Installing a Power Supply](#)
- [Fan Modules](#)
  - [Removing a Fan Module](#)
  - [Installing a Fan Module](#)

### E.1 Considerations

Review the following considerations when installing the device.

- All fans and power supplies are hot swappable.
- The switch can be running while a power supply is being installed or removed, but the power supply being replaced must not be connected to a power source.
- All slots must be filled or covered with a blank for operation (even though power supply or fans may not be functional).
- Before you begin, refer to the *Arista Networks document Safety Information and Translated Safety Warnings* at <https://www.arista.com/en/support/product-documentation>.



**Note:** Descriptions for the removal and replacement of power supplies and fans are for a representative power supply or fan. Locations of status indicator LEDs may differ. Refer to the front and rear panel illustrations of your device to locate the appropriate LED.

### E.2 Power Supplies

The following steps are required when removing power supplies from a switch.



**Note:** Only a representative power supply module is shown in [Figure E-1: Removing and Installing Power Supply](#). For the location of the power supply on your switch, refer to [Rear Panel](#).

## E.2.1 Removing a Power Supply

1. Ground yourself with an ESD wrist strap.
2. Power down the power supply by disconnecting the AC power cable.
3. Push the power supply release lever and remove the power supply. [Figure E-1: Removing and Installing Power Supply](#).

**Figure E-1: Removing and Installing Power Supply**

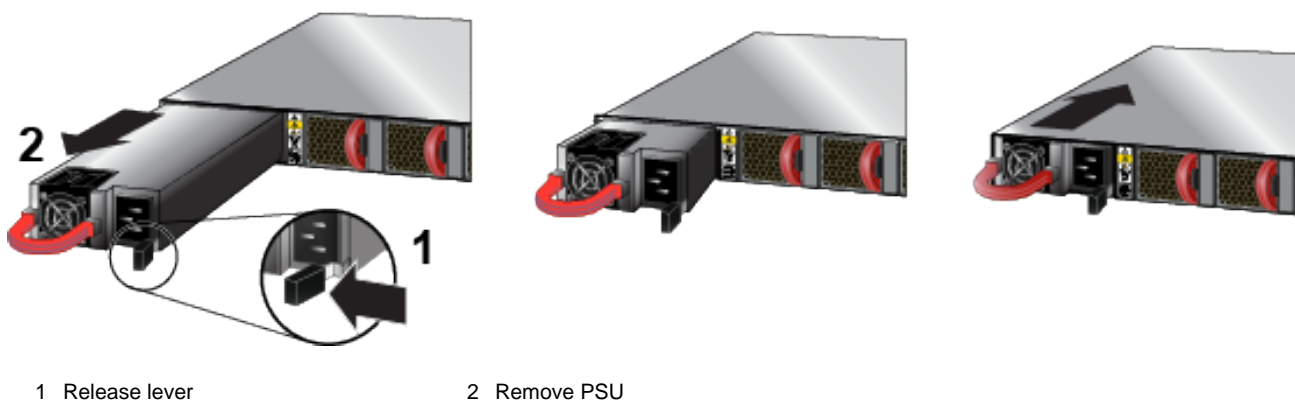

## E.2.2 Installing a Power Supply

You must make space for installing the power supply by removing an existing one [Removing a Power Supply](#).

1. Remove the replacement power supply from its packaging.
2. Slide the new power supply into the empty slot.
3. Slide the new power supply into the switch until the power supply is fully seated and the release lever snaps into place [Figure E-1: Removing and Installing Power Supply](#).
4. Connect the power cord to the power supply.
5. Verify the LEDs on the power supply.



**Note:** The Power Supply status LED should be a steady green for normal operation.

6. Verify the new power supply operation by issuing the show environment power command.

```
switch# show environment power
```

7. The output of the command will list the power supplies in operation and should include the one you replaced.

## E.3 Fan Modules



**Note:** Hot swap fans within 30 seconds to prevent the switch from overheating. Ensure that the module you are replacing matches those already installed in the switch.

### E.3.1 Removing a Fan Module

The following steps are required when removing or replacing fans from a switch.



**Note:** Only a representative fan module is shown in [Figure E-2: Removing Fan Module](#). For the location of the fan modules on your switch, refer to [Rear Panel](#).

1. Ground yourself with an ESD wrist strap.
2. Push the fan module release lever and slide the fan module out of the switch.

**Figure E-2: Removing Fan Module**

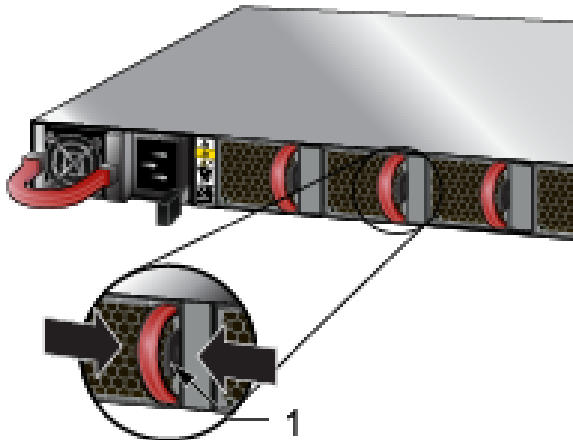

1 Release lever

### E.3.2 Installing a Fan Module

You must make space for installing the fan module by removing the existing one.

1. Remove the replacement fan from its packaging.

- Slide the new fan module into the switch until the module is fully seated and the release lever snaps into place (Figure E-3: Inserting Fan Module).

**Figure E-3: Inserting Fan Module**

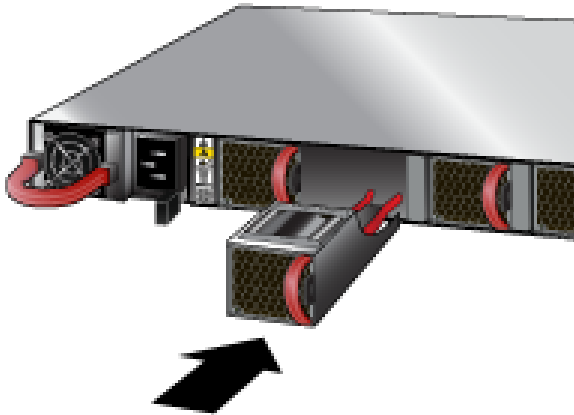

- Verify that the fan module is working normally.



**Note:** The fan module status LED should be a steady green for normal operation.

## Regulatory Model Numbers

---

This section lists the Regulatory Model Numbers (RMNs), where applicable, for the product models for the switches described in this document.

**Table 13: Regulatory Model Numbers and Product Numbers**

Regulatory Model Number (RMN)	Product Number(s)
AN2220	DCS-7280R4-32PE DCS-7280R4K-32PE
AN2221	DCS-7280R4-32DE DCS-7280R4K-32DE
AN2217	DCS-7280R4-64QC-10PE DCS-7280R4K-64QC-10PE

## Taiwan RoHS Information

---

This section provides the Taiwan RoHS information for switches covered by this guide.

台灣RoHS相關資訊請參考下列網址

<https://www.arista.com/assets/data/pdf/AristaBSMIRoHS.pdf>